



EMI Shielding and Thermal Management in Advanced Designs

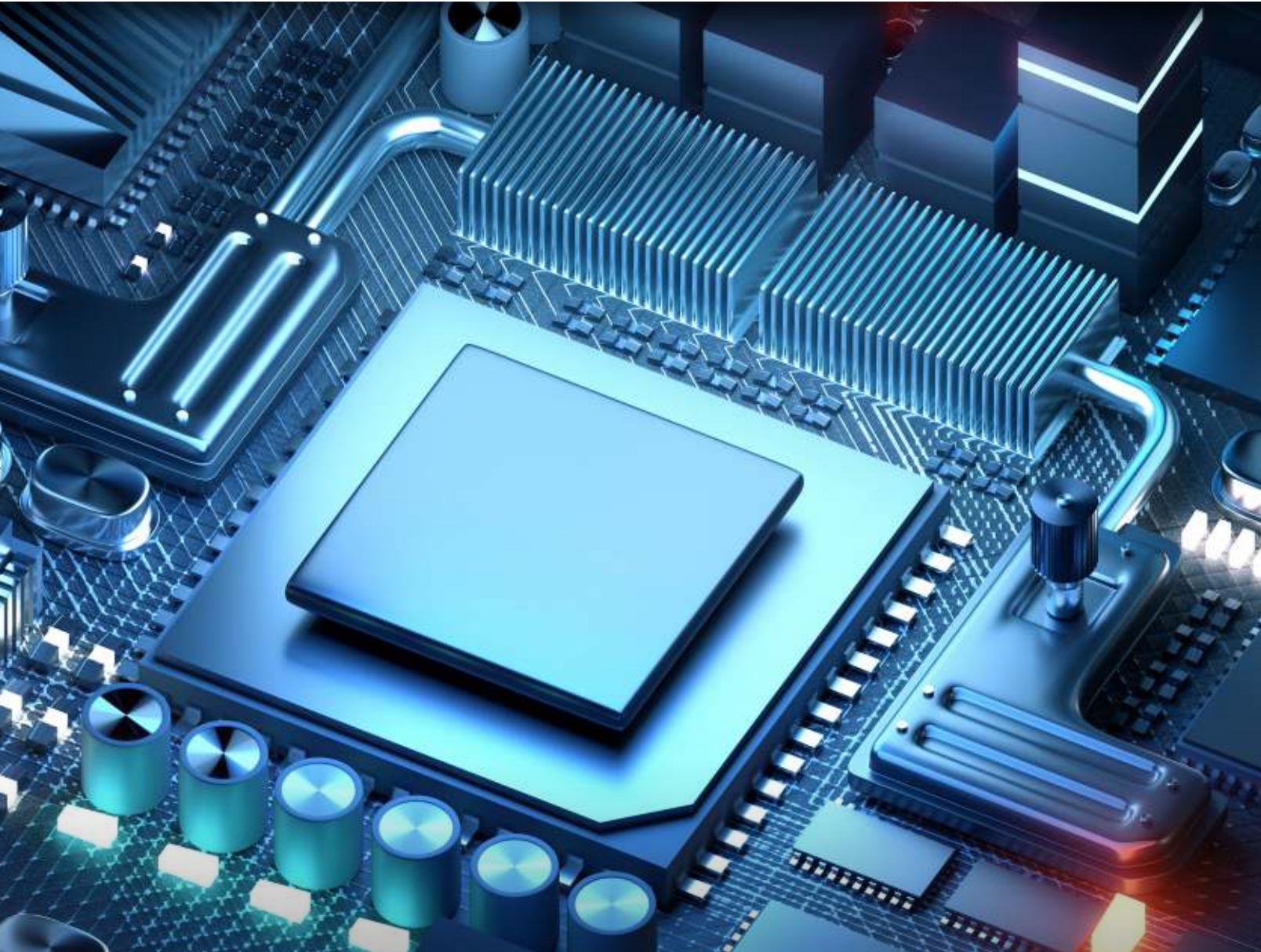

TABLE OF CONTENTS

Introduction 4

KENTON WILLISTON

Editorial Director

Interference Technology | Electronics Cooling

One Simple and Accurate Method of Inductor AC Loss Measurement Under Dynamic Conditions 5

JACKEN ZHANG

Laird/Steward Electrical Engineer

Impact of TIM Dielectric Constant on EMI Radiation 9

PAUL DIXON

Laird Staff Scientist

For Design Engineers, The Future is Multifunctional 15

ERIC TRANTINA

Product Manager for Integrated Solutions and EM Absorbers

The Two Biggest Challenges in Making 5G Hype a Reality 17

PAUL DIXON

Laird Staff Scientist

INTRODUCTION

For over 50 years, *Interference Technology* magazine has been the industry's leading resource for technical information and news concerning EMI, SI, PI and EMC. Since 1997, its sister publication *Electronics Cooling* magazine has provided pertinent material, technical data, and articles covering thermal analyses and the most common materials and their associated thermal properties used in electronics packaging. We are beyond excited to leverage our combined experience and partner with Laird Performance Materials to produce our first guide highlighting EMI shielding and thermal management design.

Laird Performance Materials facilitates the production of high-performance electronics by creating innovative protection solutions for components and systems. World-leading technology brands rely on Laird Performance Materials for improved protection, higher performance and reliability, custom structural designs, and faster time-to-market.

Welcome to **EMI Shielding and Thermal Management in Advanced Designs**

The guide offers high-level content focused on a new test method for measuring complex power inductor AC loss measurement. The newly developed test is suitable for all magnetic elements and particularly convenient for AC-AC and AC-DC power supplies like those found in inverters, charging stations, wireless charging applications, and complicated coil designs.

Additionally, we cover how design engineers can use multifunctional solutions to address growing challenges around high-speed and high-volume data transfer and the increasing amounts of EMI noise and heat they create.

Other topics covered include: how collaboration can help overcome heat issues, EMI in high-performance 5G devices, and how thermal interface materials with low dielectric constant can have an impact on EMI.

Thanks and enjoy reading,

Kenton Williston - Editorial Director
Interference Technology | Electronics Cooling

One Simple and Accurate Method of Inductor AC Loss Measurement Under Dynamic Conditions

By Jacken Zhang, Electrical Engineer



Author's note: *Electronic circuits increasingly operate under high frequency and high power. Do we really understand the challenges of AC loss measurement of the magnetic components? Do we still face trouble about it or suspect the performance of the component but can't verify it? No worries, Laird™ Steward™ expertise will provide economical, fast and practical testing methods to measure AC loss under high frequency/high power conditions, freeing design engineers of worries about unexpected and excessive losses.*



The ease to adopt higher power through new technology and topology such as SiC and GaN processors, photovoltaic power generation and the wide use of wireless power transfer- indicated power efficiency has become an important topic throughout the industry.

Magnetic components are now very commonly used in the high frequency spectrum and within decent AC current working environments (figure 1 & 2). Under this condition, coil loss not only depends on the DC resistance of the wire, but also on the high frequency AC resistance, the design of the coil and high frequency testing for verification. All become very important.

Using litz wire to reduce the AC loss has become common by design engineers, but while quantitatively evaluating thermal and electrical performance of these multi-strands litz coil designs under actual operating conditions, both computing simulation and test verification are extremely challenging. The challenges become increasingly prominent under high frequency and high-power conditions, which directly affect the success of electronic circuit design.

Figures below show adequate AC current in the system:

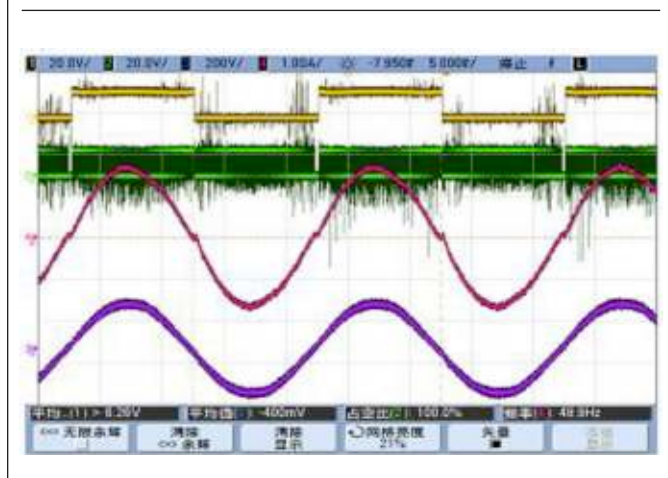
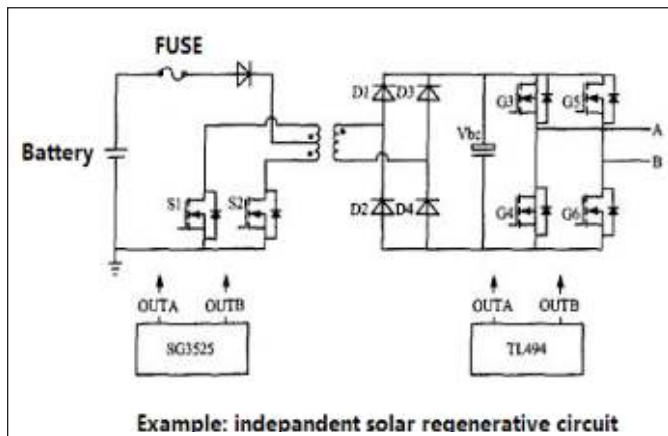

(Figure 1: Circuit diagram of an solar inverter and its current waveform)

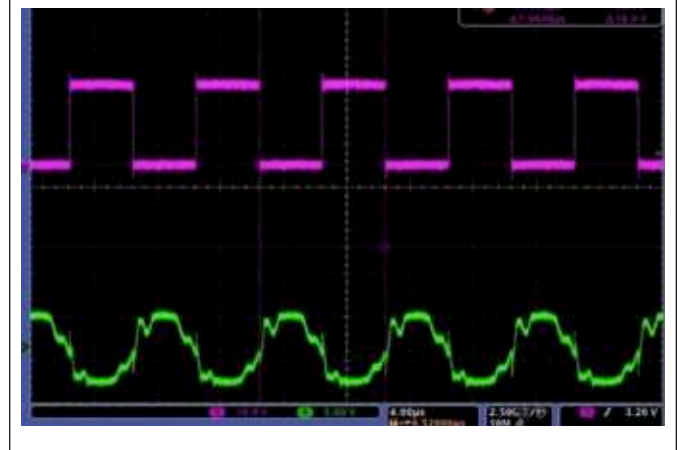
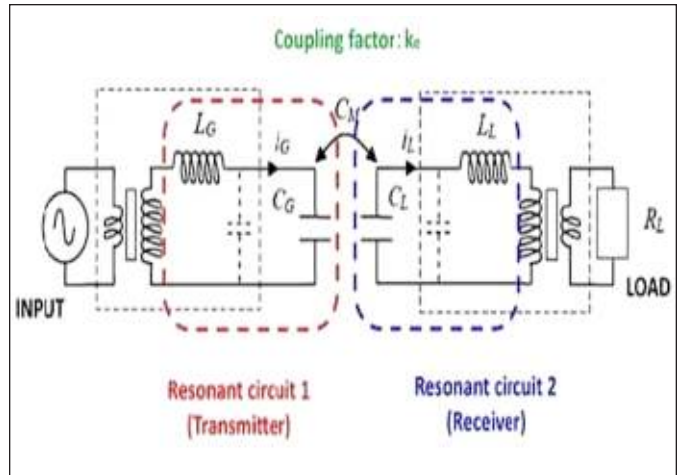

(Figure 2: Circuit diagram of a wireless charging system and its current waveform)

The Necessity of Loss Assessment Under Actual Operating Conditions: Loss Must be Tested

At present, magnetic materials loss data are measured on a standard magnetic toroid in sine wave voltage. There is still no theoretical way to conduct high frequency coil loss analysis. There is also a large gap between the simulation and the actual loss under actual operating conditions.

- The influence of BH non-linearity and magnetic anisotropy of the actual magnetic core will lead to a great difference between the core loss in DC superposition states and the manufacturer's empirical data we used, especially in a condition close to the magnetic saturation region.
- The eddy current loss of magnetic core is closely related to the geometry of the magnetic core. The relationship between loss and the effective cross-section area of the magnetic core is in quadratic proportion. The difference between the manufacturer's empirical data derived from a magnetic toroid shape and the actual magnetic component shape used is not taken into consideration. The general equation of eddy current



loss is noted below, where R is the geometrical dimension of the product.

$$P_e = 10^{-16} \cdot \pi^2 \cdot F^2 \cdot B_m^2 \cdot \frac{R^2}{4\mu} \left(\frac{W}{\text{cm}^3} \right)$$

- Magnetic permeability is several orders of magnitude lower than the electrical conductivity. In actual conditions, the magnetic flux not only flows in the magnetic core but will also leak outside the core itself. This becomes significant if there is an air gap present in the magnetic circuit. These flux leakages have a direct relationship with the coil shape and its winding processes. The coil structure used for the standard magnetic toroid is being uniformly wound 360 degrees around the magnetic toroid. This will have very low flux leakages, while the actual coils of most designs are uniformly distributed around the magnetic core. This will affect the accuracy of core loss measurement. In turn, this non-uniform magnetic flux distribution will affect the AC loss of the coil.
- The skin and proximity mechanism of coil are nonlinear with the current amplitude and excitation signal intensity. Use of an equivalent series or a parallel resistance circuit to analyze the actual loss quantitatively is almost impossible.
- The Do well's model is based on a one-dimensional model. Most are based on a two-dimensional model. The result will be quite different from the actual three-dimensional construction. Simple coil models can use finite element analysis for use in evaluations, but finite element analyses on complex litz coils is very challenging.

Common Methods for Evaluating AC Loss of Magnetic Components: Many Limitations

Take, for instance, an actual functional printed circuit board

(PCB) from an electronic industry customer. The entire PCB or the magnetic element's total efficiency can be tested. This method can trace the influence of the magnetic component, but the specific value of the losses (especially the AC loss) cannot be obtained directly. Furthermore, most magnetic component manufacturers do not always have the system level hardware from the customer to use in measurement.

Use a high frequency signal generator and programmable power amplifier to generate needed excitation power to the magnetic component. Conduct real-time capture of the current and voltage waveforms. Use the period integral or lag phase arithmetically and obtain the loss value of the magnetic component.

An amplifier providing enough power amplitude is the key limitation to this specific test. There are three commonly used testing devices:

1. A high-precision analyzer such as Iwatsu SY-8217/8232 to provide power in the range of 150~300VA. This normally is insufficient for today's needs.
2. A high frequency power generator and high bandwidth oscilloscope to capture the waveform and do mathematical calculations. Because of this method needed to analyze the phase lag angle of the waveforms, gauging the accuracy of the meter and calculation is complicated.
3. A high-frequency power generator with an external power meter to directly test the voltage and current. Here again the accuracy is not precise. The measurement error grows larger in the magnetic material with a phase angle close to 90 degrees.

Today's high-power applications have surpassed 500VA easily and cause the above-mentioned methods to be limited in their ability to measure loss accurately.

Focal Point: De-risk AC Loss Uncertainty Through a Simpler and More Practical Test Method on High Power Products

Using the difference phase angle between inductor and capacitor, 180-degree phase symmetry can be achieved under a specific frequency. This is a resonant stage with the total impedance of two components as 0. This can be realized by connecting a specified capacitor in series to the inductor. Thus, the supplied voltage or current supports only the series equivalent resistance of the magnetic element and the series equivalent resistance of the capacitor. In the case of a capacitor not being connected, the inductive reactance of the inductor and the capacitive reactance of the capacitor cannot offset each other. The total impedance is still very large so the amplitude of the inductive current will be low. This obviously cannot achieve the real inductive current under high power conditions.

Figure 3 shows the example of current amplitude to the magnetic element is increased to 0.4A with this approach compared to 0.03A before.

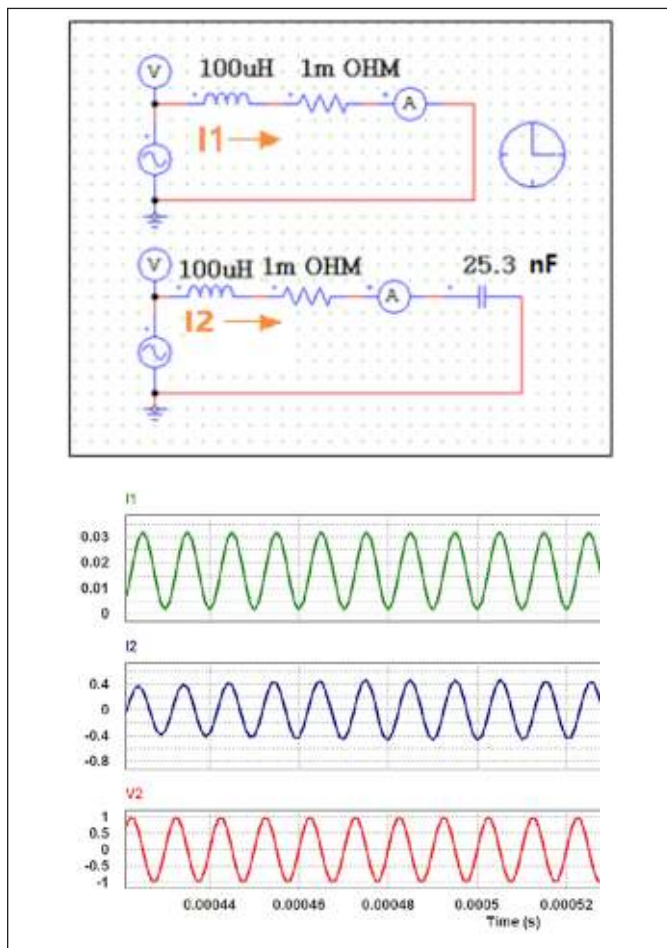

(Figure 3: Current amplitude using this resonant approach, I2 compared to without resonant, I1)

Figure 4 shows the schematic diagram on the set up. Table 1 is actual test data from this set up on one of the

Laird Steward PFC50481k series 2kW power inductors.

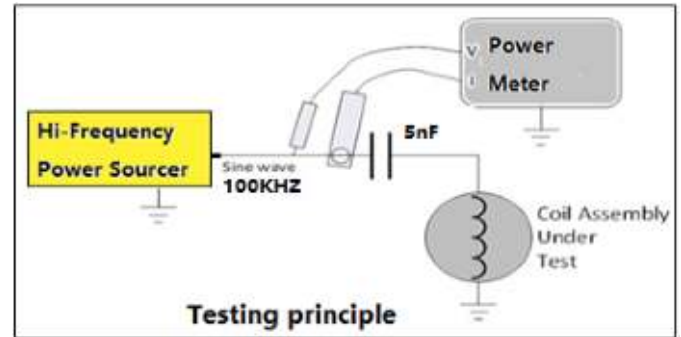

(Figure 4: Schematic diagram of the test set up)

Sample rev	A	
Frequency (KHz)	100	
Current Ripple (A, peak)	3.5	
Sourcer Voltage (V, peak)	100	
AC Loss (100KHz, W)	9.2	
DC Loss (100Hz, W)	2.1	

(Table 1: Actual test result of a Laird Steward 2kW PF-C50481k inductor with $L = 480\mu H$)

This test method is satisfactory for all magnetic elements, and particularly convenient to AC-AC, AC-DC power supplies such as found in inverters, charging stations, wireless charging applications, and complicated coil designs such as those using litz wire with high inductance and impedance. The test method is suited as well as an analytical tool on magnetic elements which experience heat issues. For high power/high frequency applications, start with the Laird Steward LDZ and PFC product series. Laird Steward offers this test as a service. Please contact your sales representative or field application engineer for further assistance.

Author's look back: Laird Steward focuses on facts to describe its products and their expected performance. We develop accurate test methods from the customers' perspective to test product performance from a real application environment. Therefore, customers have grown to trust the performance and long-term reliability of our line of power inductors.

Impact of TIM Dielectric Constant on EMI Radiation

By Paul Dixon, Staff Scientist



Common EMI sources in many systems are integrated circuits (ICs). ICs are also generators of thermal energy which must be efficiently removed via a heat sink. To enable efficient thermal energy flow a Thermal Interface Material (TIM) is used between the IC and a heat sink. Desirable qualities in a TIM are high thermal conductivity and softness to ensure good physical contact between the IC, heatsink and TIM. However it has been found that the electromagnetic properties of the TIM material can increase the EMI radiation leading to failure in regulatory compliance or deterioration in operating efficiency in the device. This has led many users to demand TIM material with a low dielectric constant (dk). This paper will investigate why the TIM dk could have an impact on EMI radiation.

Radiation from an IC

Integrated circuits contain multiple current paths that will generate radiated electromagnetic energy. The inner workings of an actual IC are far too complicated to model in terms of EM radiation. Currents are not constant and will differ based on the ICs operating mode. Therefore to model the IC we need to make some simplifying assumptions.

Source Types

A term for any object or component that radiates electromagnetic energy is an antenna. Depending on their size, shape, material properties, different antennas will radiate in different ways. Some will radiate very well, some not so well. For our purposes there are only two basic categories of antennas, linear and circular. In a linear antenna, the conductive portion is a straight line similar to the radio antenna on your car. The current is constrained by the ends of the antenna. In a circular antenna, the current is not con-strained and freely propagates out from the energy source then returns to the energy source. We have found that the best model to represent radiation from an IC is a circular (loop) source mounted vertically on a printed circuit board (PCB). The analysis in this paper regarding the impact of the dielectric constant would be very similar for any type of source.

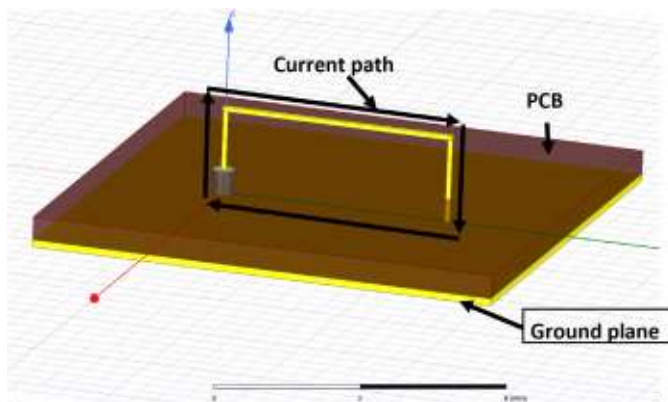

The model shown above represents a vertical loop source realized on a PCB, the current path goes from the source

at left up one conductive post then across the horizontal conductive portion then down the second conductive post and returns to the source via the conductive ground plane. In our model the antenna height is 2mm and the antenna length (horizontal portion) will vary.

Model

In our model we will inject energy at the source. We will then calculate Total Radiated Power (TRP) at each frequency of concern. TRP is calculated over a full 360 degree sphere. An efficient or 'good' antenna will radiate more energy than an inefficient or 'bad' antenna. First we will calculate the impact of the antenna length on the TRP. We used values for the length equal to 3, 5, 7, and 9mm. TRP is calculated in dBm which is milliwatts on a decibel scale. 0 dBm=1 milliwatt, -10 dBm=0.1 milliwatt, -20dBm =0.01 milliwatt etc.

As seen in the results below, the larger the antenna, the greater the total radiated power. This is a general principle in microwave engineering that, all else equal, the efficiency of an antenna is directly proportional to its size.

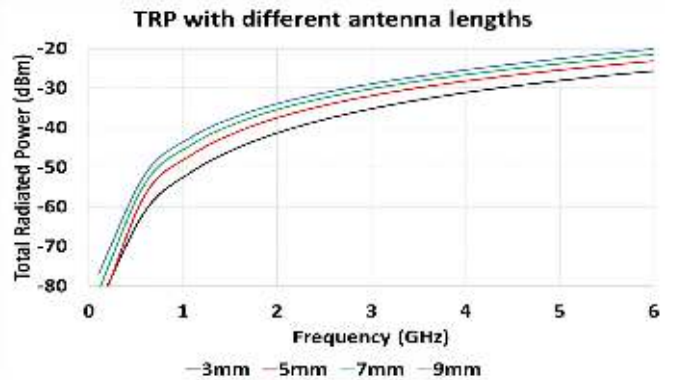

Now what happens if we embed the antenna inside a material with a dielectric constant? The model below has the antenna in free space (vacuum) where the dielectric constant equals 1. What if it was inside a material with dielectric constant equal to 5, 10, and 20?

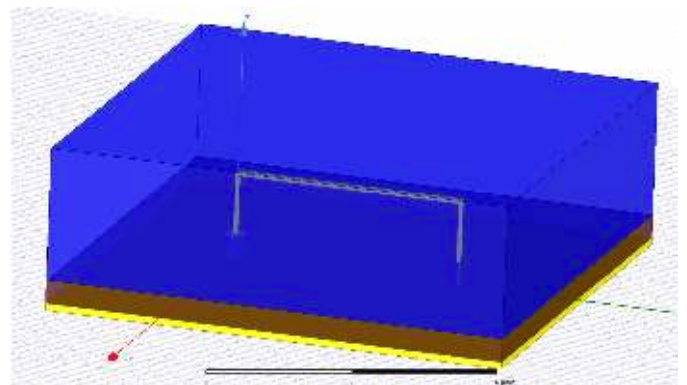

The TRP increases proportionally to the dielectric constant. Why would this be? The graph's x-axis is the frequency in GHz. As the frequency increases, the wavelength gets shorter (see end note Electromagnetic Radi-

ation). The antenna length is constant. The wavelength will compress (become shorter) inside a material with a dielectric constant (see end note What is the 'Dielectric Constant?'). Due to this wavelength compression, embedding the antenna inside a material with a dielectric constant will make the antenna larger in terms of a wavelength. It will therefore radiate a larger amount of power.

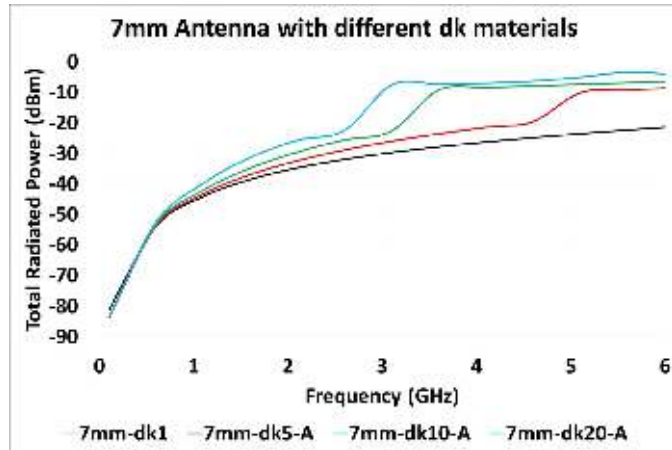

But we're not embedding the IC/antenna into a TIM material. We are placing the TIM material on top of the IC. What would be the impact then?

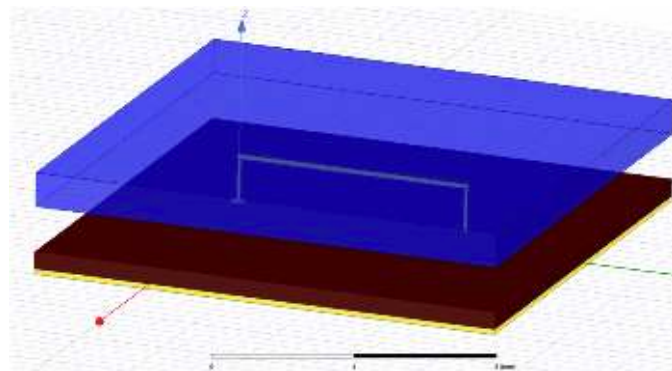

There is still a significant impact on the radiated power induced by a high dk TIM material.

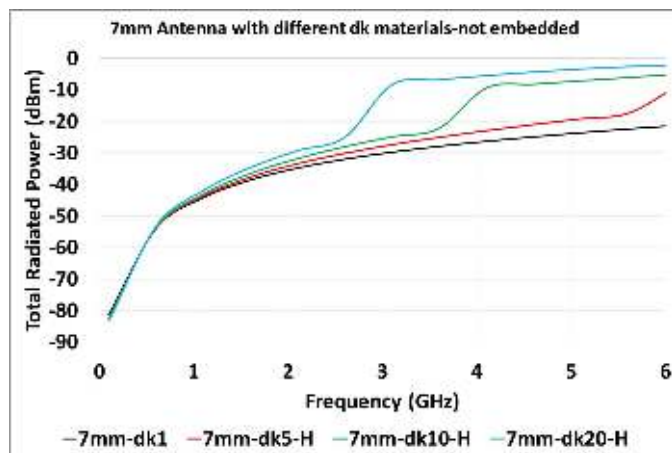

What if we add a heat sink?

In an actual application the TIM will contact a heat sink.

Heat sinks are generally made of metal so electromagnetically they can be treated as a perfect electrical conductor.

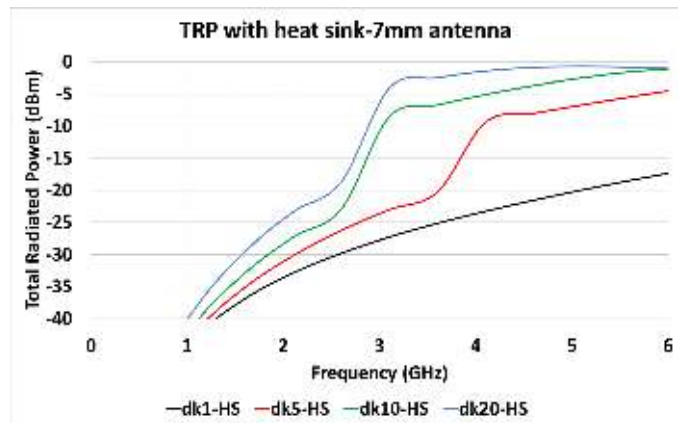
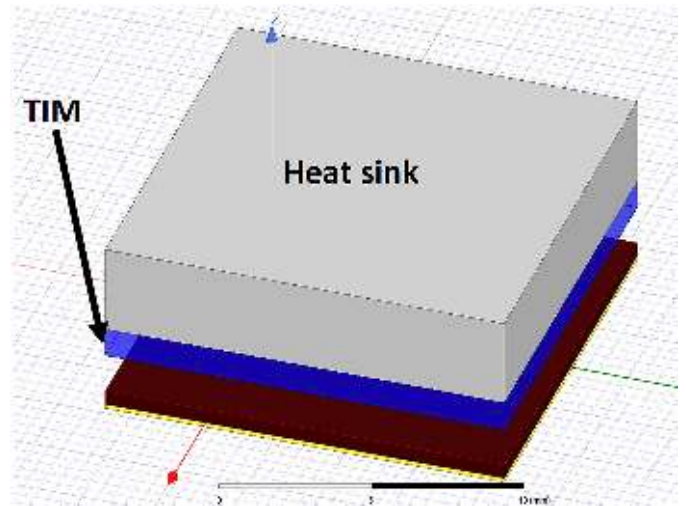

The same general conclusions apply when the heat sink is added to the model. A higher dk results in increased radiated emissions.

Can absorber help?

What if we replaced the TIM material with a Coolzorb type material. Coolzorb is designed to absorb electromagnetic radiation while maintaining the thermal conduction properties of a normal TIM. Could it absorb the excess energy? As with most questions about absorber, the answer is "it depends".

On the next page is the graph from above with the results of replacing the TIM with Coolzorb 600 (and rescaled for clarity). The purple line represents Coolzorb. Note that below around 4.5 GHz, the Coolzorb actually increased the radiated power while above 4.5 GHz the radiated power decreased. There are two factors going on here that compete with each other. Absorbers like Coolzorb have very high material parameters (permittivity and permeability). As noted above, this property will tend to increase the radiated power from a source. Absorbers will also absorb the energy. This will tend to reduce the radiated power.



PERFORMANCE MATERIALS
That *Protect* Electronics

www.laird.com

Absorbers • EMI Materials • Magnetic Ceramic Products • Precision Metals • Thermal Materials • Multi-functional Solutions

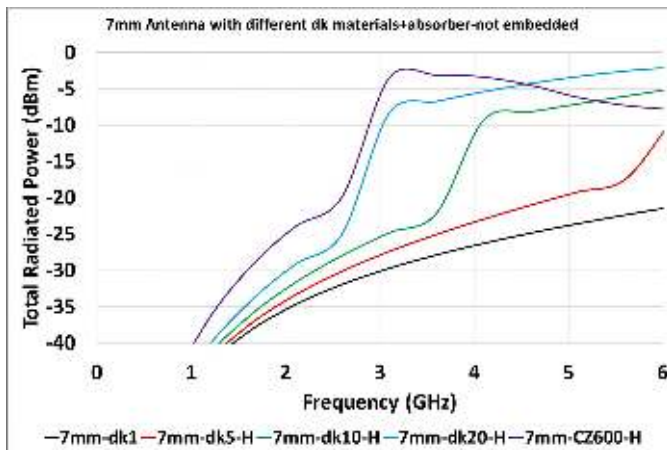

TRP with TIM material and Coolzorb Total Radiated Power

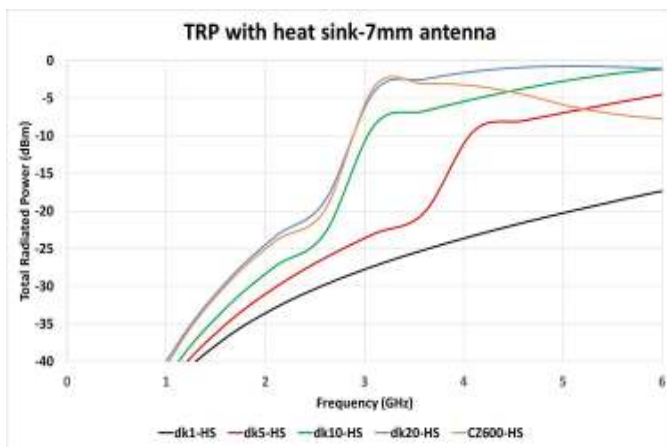

TRP with TIM material and Coolzorb+Heatsink

The attenuation of an absorber tends to increase with frequency (see end note Absorber Properties). For a constant physical volume of absorber, the amount of absorption will increase with frequency. In this model, at low

frequencies, the increase in radiation due to high material parameters is greater than the decrease due to absorption so the radiated power increases. At higher frequencies the absorption outweighs the impact of high material parameters so the radiated power decreases.

Adding a heat sink changes the results a little more. Now the TRP of Coolzorb is roughly the same as a TIM with $dk=20$ up to around 3.5 GHz. Above 3.5 GHz, Coolzorb greatly reduces the TRP. This is likely due to the heat sink constraining the energy a bit inside the material where the absorptive properties of the Coolzorb could attenuate the energy.

Note that the results here are general tendencies. We should not take 3.5 GHz as the crossing point between Coolzorb and standard TIM material. A different quantitative result will occur with different antenna lengths, TIM size, thickness etc but the qualitative results will be the same. The reality is that an IC source will be composed of multiple current sources and loop sizes in addition to other configurations so in general the frequency point of improved Coolzorb performance will vary.

Conclusions

The electromagnetic radiation from an IC was modeled using a vertically oriented loop source. This type of source has been shown to best emulate the actual radiation from an IC. Embedding the source in a material with a dielectric constant (dk) greater than 1 increases the total radiated power (TRP) vs the TRP of the antenna in a vacuum. The TRP increases as the dk increases. This phenomenon is still seen if the source is just below the material with $dk > 1$ as it would be in a TIM application. This phenomenon is due to wavelength compression in the TIM material. This wavelength compression increases the effective size of the source in terms of a wavelength which increases the radiated power.

A TIM with absorptive properties (Coolzorb) could reduce the total radiated emissions however it has limited affect at lower frequencies due to the small physical volume in terms of a wavelength. At higher frequencies Coolzorb will give significantly improved performance in reducing radiated emissions.

Laird Thermal Materials

Lairds extensive experience with both thermal and EMI management allows for a unique system level approach and understanding of thermal and EMI interactions. We offer advanced system modeling and simulation as well as other multi-functional materials to help mitigate EMI and thermal design concerns.

If looking for a thermal material with a lower dielectric constant, Laird offers products across various thermal conductivities with low dielectric constant values when measured at higher frequencies. By selecting one of the materials below, design engineers can ensure the EMI radiation of the system will not increase with the addition of the thermal material. Materials with low dielectric constant are shown in the table below.

Material	Dielectric Constant (@10GHz)	Thermal Conductivity
Tpli 200	3.2	5.0 W/mK
Tflex SF600	3.5	3.0 W/mK
Tputty 502	3.6	3.0 W/mK
Tflex 600	4.0	3.0 W/mK
Tpcm 905c	4.2	0.7 W/mK
Tflex 300	4.5	1.2 W/mK

Absorber Properties

As the name implies, absorbers will absorb or attenuate electromagnetic energy. Absorbers tend to have high values for their permittivity and permeability with high loss components (imaginary portion of permittivity/permeability). A common metric used to differentiate absorbers is called the attenuation which is calculated from the material parameters and is reported in units of dB/cm. This represents how much the wave is attenuated per distance of travel inside the material. A higher value means that more is absorbed.

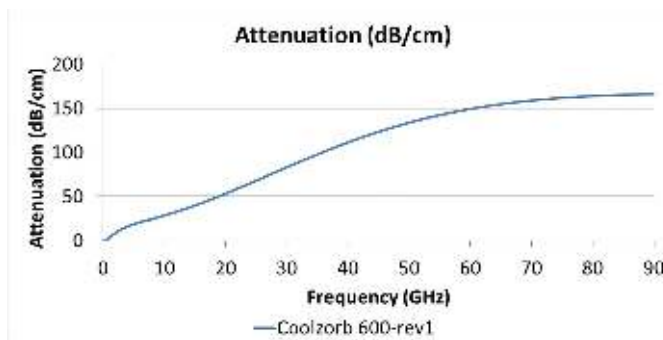

The attenuation for Coolzorb 600 up to 90 GHz is shown above. Note that the attenuation increases with frequency.

At first glance you may infer that the material is becoming inherently more absorptive (higher values for loss factors of permittivity and permeability as frequency increases) but this is not true. In fact the inherent loss values actually decrease as the frequency increases. The increase in attenuation with frequency is entirely due to the wavelength becoming shorter as the frequency increases.

The loss factors for permittivity (electric) and permeability (magnetic) are an indication of loss per wavelength traveled. The attenuation is in terms of loss per centimeter traveled. If we cram more wavelengths into a shorter distance, the attenuation in dB/cm will increase.

Even though absorbers have very high loss factors at low (<3 GHz) frequencies, in a practical application there may not be enough physical volume of absorber material to give acceptable absorption. This becomes less of an issue as the frequency increases.

Electromagnetic Radiation

The sources of electromagnetic radiation are electric currents which are electrons moving due to an applied voltage or electric field. Electrons move very easily through conductive materials such as metals.

EM radiation arises from AC or alternating currents. Alternating currents occur when the direction of the electron flow switches direction (alternates) back and forth in a conductor. The number of times per second that the current switches direction is called the frequency. The frequencies of interest to us are in the MHz (Megahertz-millions of cycles/second) and GHz (Gigahertz-billions of cycles per second) so this current switching is quite fast.

EM radiation propagates at the speed of light in a vacuum. Light is actually a form of high frequency EM radiation. The frequency of visible light is approximately 500,000 GHz.

EM radiation propagates with an alternating electric (E) field and magnetic (H) field. The direction of the E and H field alternate in the form of a sine wave.

The wavelength of EM energy in a vacuum can be calculated by dividing the speed of propagation (speed of light) by the frequency. The speed of light is 3x10¹⁰ cm/sec. If the frequency is 1 GHz (or 1x10⁹ cycles/sec) the wavelength is

$$wavelength = \frac{3 \times 10^{10} \text{ cm/sec}}{1 \times 10^9 \text{ cycles/sec}} = 30 \text{ cm}$$

A handy formula to quickly calculate wavelength is

$$wavelength(cm) = \frac{30}{frequency(GHz)}$$

so the wavelength at 10 GHz is 3cm and the wavelength at 15 GHz is 2cm.

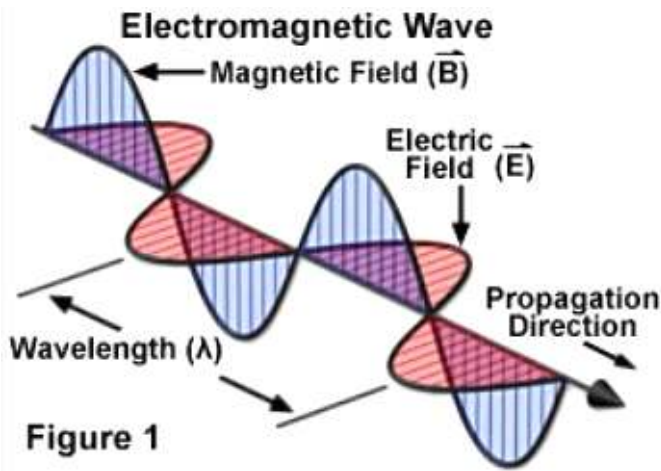

electromagnetic wave is given by the speed of the wave (speed of light) divided by the frequency. When the wave is inside a material it slows down. This results in the wavelength inside the material becoming shorter.

The imaginary part of the permittivity is a measure of loss or absorption of energy in the material. A good absorber will have a high value for the imaginary permittivity.

Note that there is an analogous material property denoting a material's affect on the magnetic field. This is called the permeability. Permeability also has a real (magnetic constant) and imaginary (loss or absorption) component.

What is the 'dielectric constant'?

Electromagnetic energy consists of an electric field component and a magnetic field component. Both fields will be modified in the presence of matter. The measure of a material's impact on the electric field is called the permittivity. Permittivity is a 'complex' number which means it has two components called the 'real' and the 'imaginary' parts. The dielectric constant is the real part of the permittivity.

The primary impact of the dielectric constant is wavelength compression. Recall that the wavelength of an

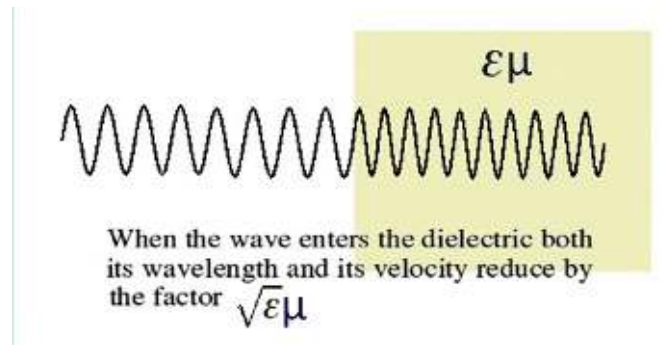

A 'dielectric' absorber will have no affect on the magnetic field (permeability=1). It will attenuate or absorb the electric field. A 'magnetic' absorber will impact and attenuate both the electric and magnetic fields.

The advertisement features a collage of electronic components and materials. Labels include: ABSORBER, MULTI-FUNCTIONAL, INDUCTOR, FABRIC OVER FOAM, THERMAL PAD, and DIELECTRIC MATERIAL. The Laird logo is prominently displayed as "Laird A DuPont Business". The main text reads "PERFORMANCE MATERIALS That Protect Electronics" with the website "www.laird.com". At the bottom, a list of services is provided: "Absorbers • EMI Materials • Magnetic Ceramic Products • Precision Metals • Thermal Materials • Multi-functional Solutions".

For Design Engineers, The Future is Multifunctional

By Eric Trantina, Product Manager for Integrated Solutions and EM Absorbers



The signature mark of today's advanced technology – whether it's autonomous vehicles, sensors that create an internet of things, or home routers – is high-speed and high-volume data transfer. Unfortunately, these data-transfer capabilities pose major challenges for design engineers.

For one, these electronics generate a significant amount of electromagnetic signal interference. This wasn't always the case for small, relatively low-powered products like routers and IoT sensors. Historically, these devices didn't produce meaningful amounts of EMI noise. That changed as these products began to operate at the higher frequencies and with the more powerful integrated circuits and systems on chips required to facilitate enhanced data transfer and product performance. As frequencies and power levels go up, current EMI-mitigation solutions are no longer sufficient. Additionally, the shorter wavelengths at higher frequencies can sneak through gaps in shielding and interfere with product operability.

But EMI is only half of the problem. More component parts in these electronics make them more powerful, but also hotter. And since no engineer can stand a clunky design – and consumers won't accept anything less than a sleek, lightweight piece of electronics – design engineers face a quandary: how to effectively mitigate EMI and transfer heat in tight (and shrinking) spaces. In most of these devices, there's simply not enough room to pile a thermal interface material and heat sink on top of an EMI-mitigating absorber. And a metal component like a heat sink may even cause more signal interference. So, addressing EMI and heat separately is no longer an option.

To ensure both elegant design and high performance, design engineers need to start thinking multifunctional. Multifunctional solutions are single or companion components that do the job of multiple parts. For instance, a multifunctional solution may simultaneously serve as both a microwave absorber and a thermal interface material. Here are some keys for how design engineers can go multifunctional to address their evolving challenges.

Put Every Part of a Device to Work

Tackling today's multifaceted design engineering challenges requires viewing every component of a device as a potential solution to EMI and heat issues. After all, given the limited real estate in these devices, design engineers must make every bit of space count.

In an autonomous vehicle, there's a plastic bracket that holds the car's radar unit. To minimize harmful EMI for one car maker, we rebuilt the bracket using EMI absorbing material. This approach enhanced the performance of the entire system by better controlling signal interference. It also made optimal use of space and helped the design engineering team create an elegant and uncluttered system. As we did in this situation, design engineers should

consider using smart materials in structural components whenever possible to solve signal and heat challenges.

Swappable solid-state drives present unique challenges, as well. As these drives transfer data faster, they produce more heat. But design engineers can't use gooey thermal interface material to transfer heat away from sensitive components on an insertable drive. Instead, for one customer, we designed graphite and springs into the cage that holds the SSD. This solution transferred heat away from the drive through the structural components of the housing.

Overhaul Workflows to Enhance Design

To successfully navigate the multifunctional future, company leaders must break down the walls that commonly exist between mechanical, thermal, RF and package design groups within a design engineering team. These groups need to understand that the problems they often address separately are increasingly interrelated. Working together to solve EMI and heat challenges early in the design process will help the team make better use of space on the board and build a more reliable and higher-performance product.

When design engineers work in silos, they often don't identify problems until late in the design process. Approaching product design holistically will minimize the risk of having to delay production and re-engineer the product. Engineers designing a consumer-grade router may only notice a problem with EMI noise after designing the board, as they work to boost the amount of wireless coverage the router can provide. The team may have to re-design the board to accommodate the addition of EMI-reducing shields or absorbers – and only then deal with any thermal implications of the change. However, if the teams worked together from the start to pre-emptively address EMI and heat issues together, they could have integrated a multifunctional solution into the board design, leaving maximum room for performance-boosting components.

Plan for a Multifunctional Future

Heat and EMI challenges will only grow as electronics transfer ever-larger quantities of data faster to meet business and consumer needs. So, design engineers have no choice but to embrace the multifunctional future. Though Laird has developed a suite of multifunctional solutions that address both EMI and heat, it's important to understand that multifunctional solutions are not just a product line. Instead, they are an approach to design engineering. Design engineers must tap material sciences ingenuity to meld different products into new solutions and develop creative, custom fixes to their most challenging issues. The future belongs to those who embrace this multifunctional approach.

Eric Trantina is a product manager at Laird Performance Materials. He specializes in helping companies across industries deploy multifunctional solutions to solve EMI, thermal and structural challenges.

The Two Biggest Challenges in Making 5G Hype a Reality

By Paul Dixon, Staff Scientist

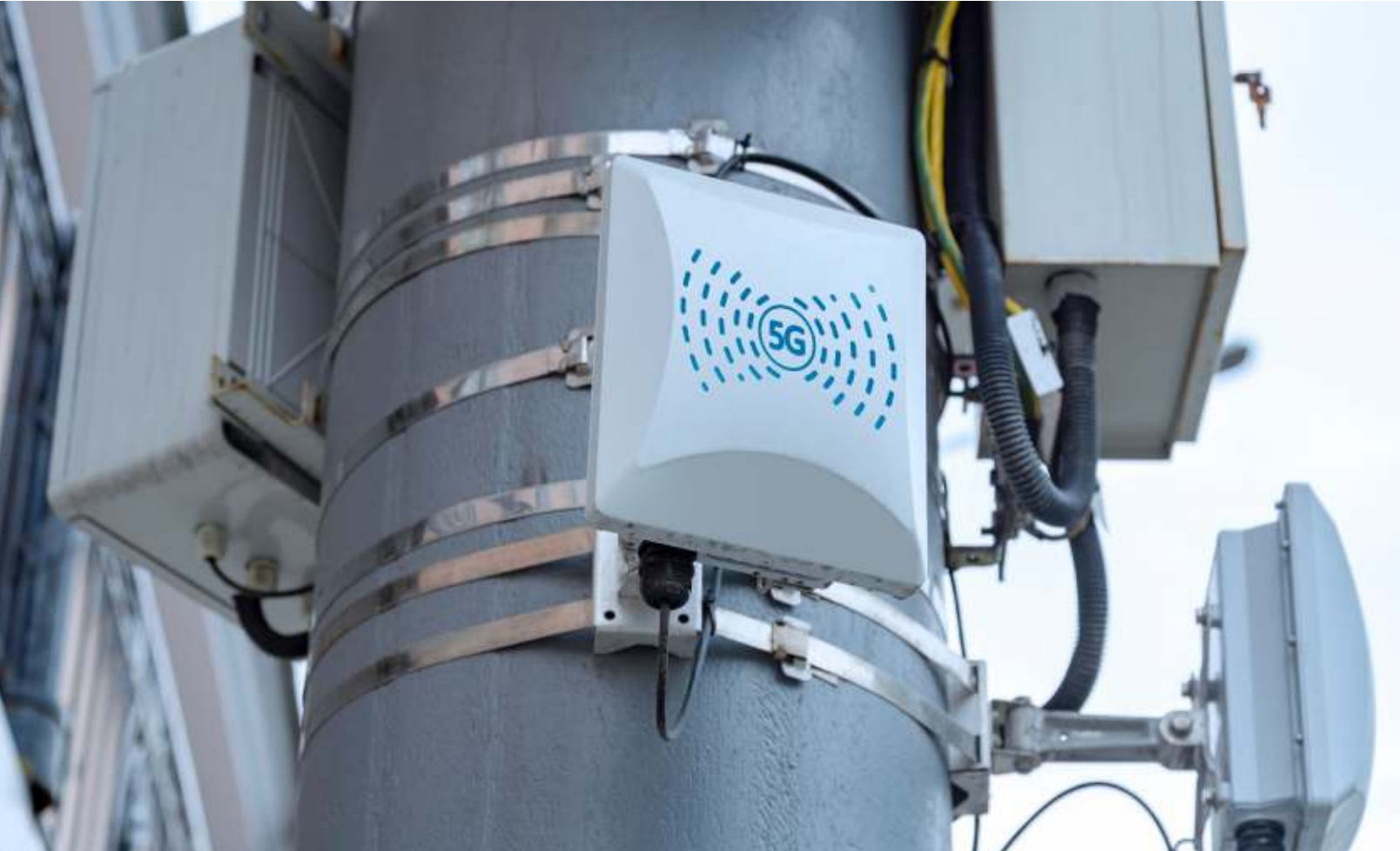

5G hype is everywhere you look. From electronics manufacturers to the military to consumers, it seems everyone is itching to capitalize on the ability to transmit more data, more precisely and faster than ever before.

The impact of 5G promises to be huge. IHS Markit estimates that 5G will enable \$12.3 trillion of global economic output in 2035. Potential applications for 5G are nearly endless. Technologies like virtual reality gaming will thrive on 5G. 5G will likely also play a key role in the high-volume data exchange that will be part of autonomous driving advancements. More immediately, 5G will facilitate the advent of fixed wireless access, which untethers homes and businesses from fiber optic lines, delivering hyper-fast internet speeds through wireless beams.

For all its promise, however, 5G also poses some vexing challenges for the design engineers who build the hardware that will make all this potential a reality. The challenges emanate from the fact that 5G operates at higher frequencies and requires putting more high-powered electronics in tinier and more compact spaces. As a result, 5G produces overlapping challenges related to electromagnetic interference (EMI) and heat. If design engineers don't address these issues effectively, they risk producing unreliable hardware and even running afoul of FCC regulations.

The advent of 5G is great news for all consumers of data. But the stakes are high for design engineers to innovate and devise solutions to the complex, multifaceted challenges that accompany 5G.

The Catch-22 of EMI and Heat

The most immediate application of 5G technology is in the base stations that will send signals for fixed wire-

less access. 5G base stations utilize the millimeter wave range, where large amounts of bandwidth are available. This higher frequency spectrum enables the transfer of large amounts of data. And with low latency, the delay between issuing a command and execution of a command becomes short enough to enable real-time operation in fast-moving systems.

Further, 5G base stations use multiple in-multiple out (MIMO) antennas to facilitate spatial multiplexing. In layman's terms, this means that antennas send signals directly to users, which prevents the familiar problem of overloaded cell networks. However, all of this requires a large number of antennas – MIMO arrays at mmWave typically use 64 or 128 elements. Each element requires its own power amplifiers and analog-digital converters – all within a very tight space (we're talking as small as eight centimeters on a side). These tightly packed electronics produce significant amounts of heat that design engineers must dissipate to ensure reliable operability.

Traditionally, engineers would use a metal heat sink to manage heat (a thermal interface material is often used between the heat source and heat sink to enhance the thermal coupling between these two components). However, putting metal heat sinks next to antennas can create an electromagnetic interference problem. Thus, by fixing the heat problem using traditional methods, design engineers may create an EMI problem.

Things don't get any easier when we turn to EMI. The effectiveness of typical EMI mitigation tools such as board-level shields decreases with higher frequencies, because smaller wavelengths make it easier for energy to leak through gaps in shields. This of course poses a problem at mmWave. Further, cavity resonance, which occurs when a conductive enclosure is larger than half

The advertisement features a dark background with a grid pattern. On the left, several product samples are shown: a blue thermal pad, a white fabric over foam, a white dielectric material, and a blue thermal putty. In the center, there are images of precision metal components and an inductor. The Laird logo, 'A DuPont Business', is in the top right. The main text reads 'PERFORMANCE MATERIALS That Protect Electronics' with 'That Protect Electronics' in a larger, bold font. Below this is the website 'www.laird.com'. At the bottom, a list of product categories is provided: 'Absorbers • EMI Materials • Magnetic Ceramic Products • Precision Metals • Thermal Materials • Multi-functional Solutions'.

THERMAL PAD

FABRIC OVER FOAM

DIELECTRIC MATERIAL

THERMAL PUTTY

INDUCTOR

PRECISION METAL

Laird™
A DuPont Business

PERFORMANCE MATERIALS
That *Protect* Electronics

www.laird.com

Absorbers • EMI Materials • Magnetic Ceramic Products • Precision Metals • Thermal Materials • Multi-functional Solutions

a wavelength, can cause trouble at higher frequencies.

Within any piece of 5G technology, there's an internal battle taking place between electromagnetic interference and heat. It seems like a Catch-22. But design engineers can tackle the problem. Here's how:

1. Remove Silos in the Design Process

Too often, design engineers address electromagnetic interference and heat during separate stages of the design engineering process. These two issues are sometimes even dealt with by different teams. This siloed approach is inefficient no matter if the project is 5G-related or not. But it is increasingly untenable with 5G, given the interrelated EMI and heat challenges.

It's crucial that design engineers break down barriers between teams and work together to address EMI and heat challenges. A streamlined approach will enable them to shorten the design cycle and move products to market quicker.

2. Include Protective Components in Your Blueprint

There's a misconception among some design engineers that if they use protective components like absorbers, they are tacitly admitting that their designs are somehow fundamentally flawed. That couldn't be further from the truth – especially when it comes to 5G devices. In fact, with 5G, I'd argue it's impossible to design around protective components like absorbers, which increase in effectiveness at higher frequencies and can help address heat sink-generated EMI issues at mmWave. Of course, there are many different absorber materials (everything from poly-

urethane foams to silicone or urethane elastomers) and a variety of product-specific considerations that go into determining the precise absorber solution for a particular piece of hardware.

But the fact remains that these protective components are essential elements of 5G devices. As pressures on design engineers mount – and design cycle times shrink as companies seek to meet market demand – they can't afford a setback, especially one that could be traced back to a reluctance to incorporate protective components. So, make protective components such as absorbers a fixed piece of the bill of materials at the beginning of the design process. Design engineers that don't account for these protective components run the risk of having to go back to the drawing board – which delays production and wastes time and money.

3. Think Multifunctional

While there's no one-size-fits-all solution to EMI and heat challenges in 5G technology, multifunctional products are coming on the market that enable design engineers to address EMI and heat issues simultaneously and save space within devices. These products essentially act as heat-mitigating gap fillers and EMI-reducing absorbers. Innovation is constantly happening in this emerging area. So, as design engineers develop 5G devices, they must stay on top of industry developments to ensure they're using the most advanced solutions.

The future of 5G is in the hands of design engineers. They can speed its accessibility and impact by thinking strategically and in a unified way about EMI and heat.

