

CONSIDERATIONS IN EMI ANTENNA DESIGN

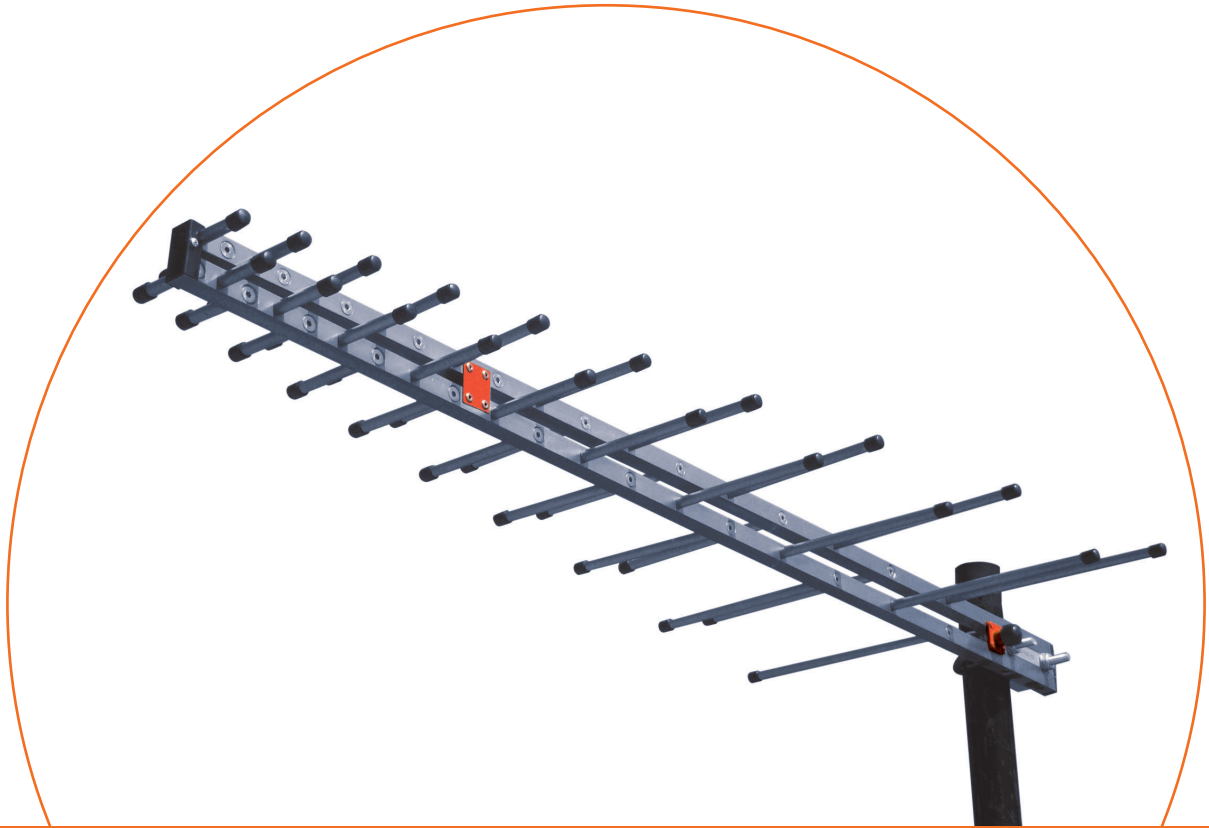

When considering an antenna, one must look for the proper balance, smooth antenna factor curves devoid of discontinuities, and 3-dB beamwidths to optimize performance.

Considerations in EMI Antenna Design

The antennas used in ElectroMagnetic Compatibility (EMC) testing, and, specifically, in ElectroMagnetic Interference (EMI) testing, have some significantly different considerations than antennas that are used in other industries (e.g., the communication industry). The antennas required for EMI testing require very wide bandwidths. Also, these antennas are used at very short distances from the Equipment Under Test (EUT). That is, the antennas are used in a region called the radiated near-field, or Fresnel zone. Achieving balance becomes a crucial consideration, especially at the lower frequencies (e.g., below 80 MHz). Lastly, test configuration is a limiting factor, as these antennas are used mostly in small enclosures, over metal ground planes, which puts restrictions on the size of the antennas.

The important parameters for EMI antennas are enumerated below:

- Frequency Range
- Free-Space Conditions (or lack thereof)
- Polarization
- Balance
- Antenna Factors

The frequency range must match the required specifications as per the given standard, based on the industry into which a product will be sold. The most typical frequency range is 30 MHz to 6 GHz, but could be wider (lower and higher), depending on the market into which a product is being sold, and the standard being applied. These antennas must operate over a very broad bandwidth.

One limitation affecting the performance of EMI antennas is the test configuration. Most commercial EMI testing involves the antenna mounted onto an antenna tower and having the mid-point of the antenna raised from 1 m to 4 m in height. According to CISPR 16-2-3, the minimum distance that the element can be from the ground plane is 25 cm. This limits the width, and thus, the electrical size of the antenna that is used, because the elements get very close to the ground plane in the vertical polarization.

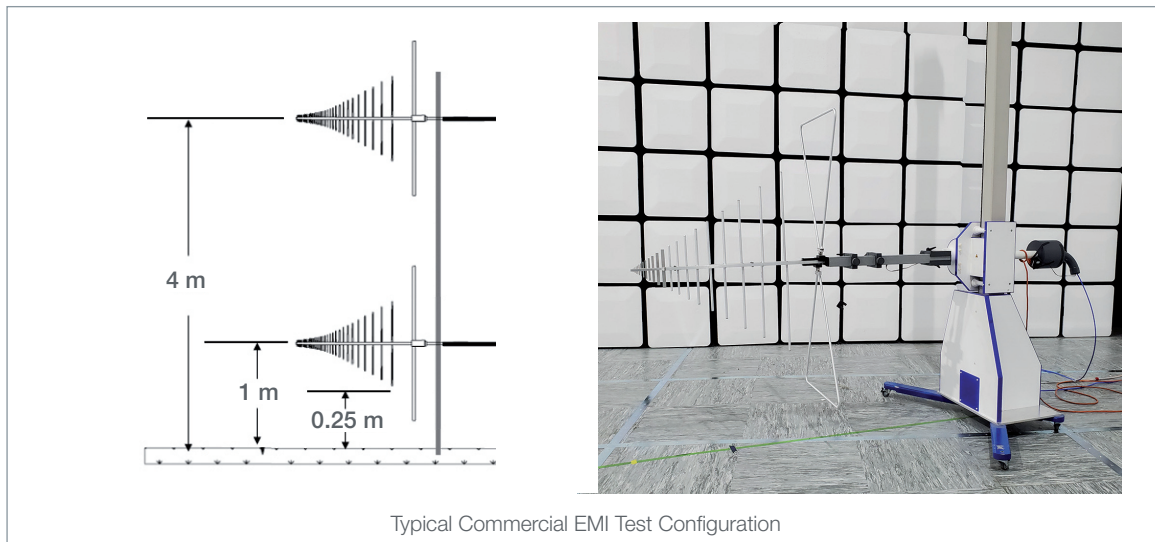

Similarly, the configurations specified in other standards, such as CISPR25 or MIL-STD-461, commonly referenced for benchtop testing for automotive and military applications, respectively, place limitations on the size of the antenna. Additionally, the small enclosures commonly used - and the specifications for distance to the floor, wall, or ceiling - limit the size of the antenna as well. Achieving the best performance over such a broad frequency range, with limitations on the electrical size, can be challenging.

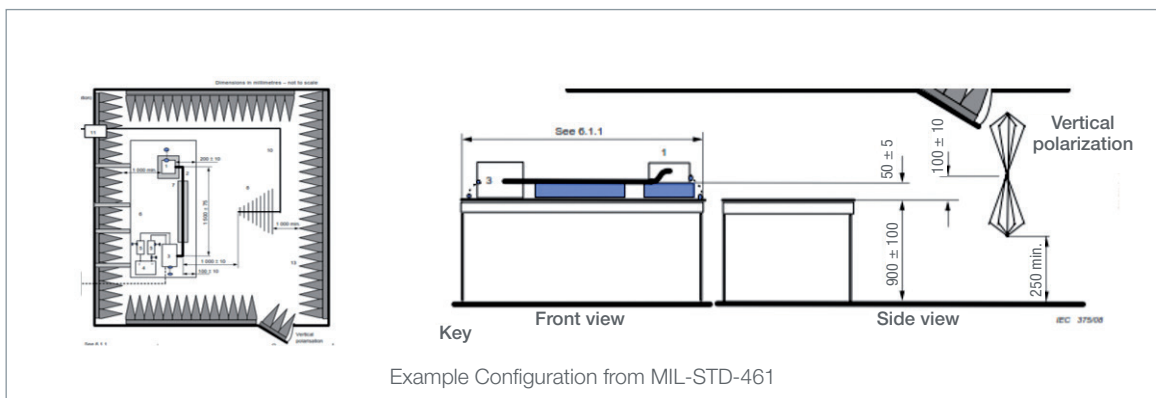
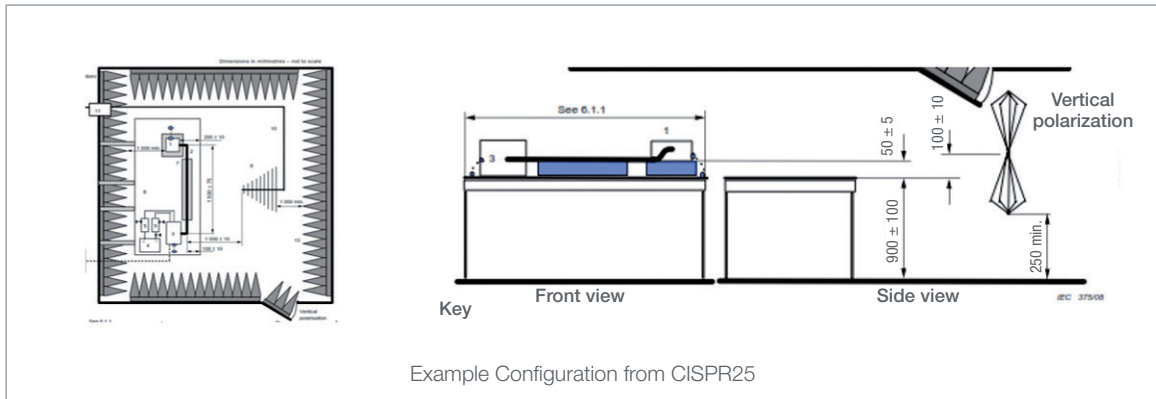

In most test scenarios, the EMI test distance is short, and thus, the antennas are not operating in the far-field (or Fraunhofer) region, and they are not operating in free space conditions. One of the most commonly used terms to define the far-field region is a distance of $R = 2D^2/\lambda$, where D is the largest dimension across the aperture of the antenna. When placed at this distance, sufficient separation is provided so that the spherical wave front appears to be flat across the aperture of the antenna. This term results in about 22.5° of phase taper across the aperture. This is approximately the point at which the first null of a high-gain antenna pattern begins to fill in for high-gain antennas (an important concept in antenna measurements). For EMC testing, this distance could affect the field intensities being measured, and thus, the emissions detected and reported. Two antennas could have exactly the same maximum far-field gain and produce exactly the same electric field intensities for a given input power at a point in the far-field, but exhibit drastically different electric and magnetic field intensities in the near-field. Also, in the near-field, very small changes in positioning of the antenna in any direction can have big effects on the intensity being read.

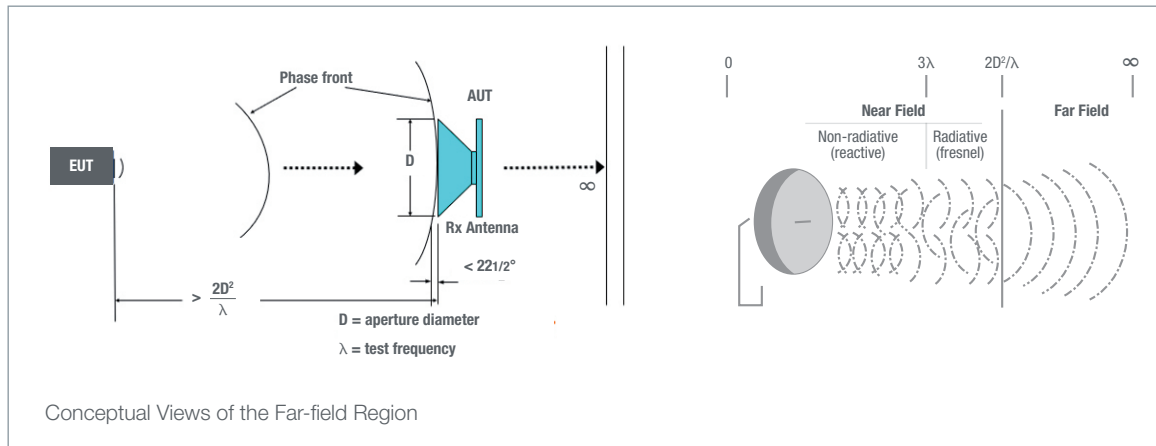

For radiated EMI testing (which test for emissions that are radiated from an EUT), standard frequencies covered for commercial testing are 30 MHz to 6 GHz. But this can be extended up to 18 GHz, or even expanded to cover 9 kHz to 40 GHz, depending on the standard, and if the device is an intentional radiator. In the 5G world, and when testing intentional radiators, the frequencies will extend into the mm-wave frequencies. This will cause very long far-field distances.

Also, the low frequencies required in EMI testing mean that wavelengths up to 10 m long (and even 30 m long, in some cases) are being tested. At these frequencies, test distances begin to approach $\lambda/2\pi$, which indicates that the antenna is not only in the near-field region, but is very likely in the reactive near-field region (especially for electrically small antennas). At these short test distances, and such long wavelengths, the antenna will begin to couple to, and disturb, the very source we are trying to measure. Finally, the long wavelength, and electrically small antennas cause the VSWR to become much more inefficient as the frequency goes lower. This affects our ability to accurately detect and measure the fields that might exist. The antennas used for EMI testing must be designed to overcome, or mitigate, these phenomena. You will see characteristics such as bent, or folded elements, and other factors to overcome the inefficiencies.

In EMI testing, most antennas used and specified by the standards (e.g., CISPR 16-1-4) are plane polarized (linear polarized) antennas. The measurement must be done so that the antenna can be oriented in two orthogonal polarizations (typically, horizontal and vertical). This is for practical reasons as it is simpler to configure, use, and interpret the results from a linearly polarized antenna. Additionally, most radiation sources (at the lower frequencies) radiate typically in one plane. There are some exceptions (e.g., MIL-STD-461), but for the most part, the use of linearly polarized antennas is nearly universally accepted.

The test reference in the EMI standards (and many industries) is the dipole antenna. Dipole antennas are theoretically well-known and well-defined radiators. They have near-field and far-field values that can easily be calculated and ascertained. In fact, tuned dipoles would be the preferred method of EMC measurements, except that it proves to be highly inefficient, as it is extremely time-consuming to continually change and configure a set of tuned dipoles to cover the extensive frequency range. Thus, it is more practical to use antennas that are more broadband. That brings us to the antennas that are commonly used in EMI testing. Specifically, biconical, log-periodic, and dual-ridge antennas.

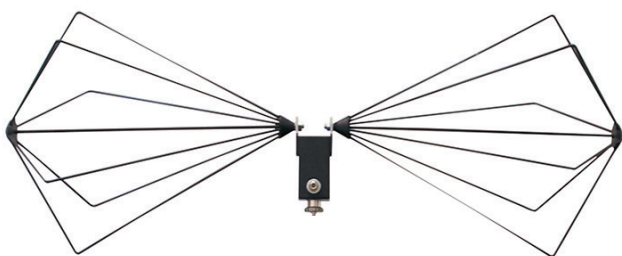

Biconical antennas are popular to cover the frequency range of 20 MHz to 300 MHz. These biconical antennas are typically "caged" dipoles that help to increase the electrical dimensions of the antennas. However, they are still electrically small (approximately 1.37 m wide) for the lower end of the frequency range due to rules that limit the size in order to maintain a minimum distance from the ground plane to limit the coupling. Thus, at the lower frequencies, the antenna begins to exhibit high VSWR and becomes inefficient.

The balun plays an important role in the effectiveness of the biconical antenna. It is an important parameter in determining the frequency range. This can be optimized via its topology and the material used. However, at 80 MHz, the input impedance to the antenna starts to become too high because of the short electrical length. At the higher frequencies, near 300 MHz, the length becomes too long, the directivity begins to decrease, and the antenna pattern begins to become distorted. Below, one can see the typical VSWR and antenna factor curves for a biconical antenna.

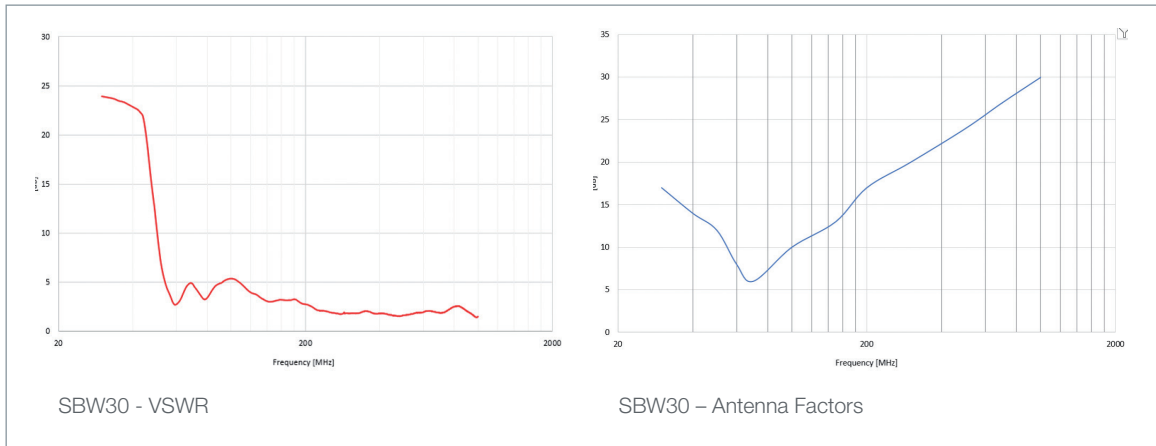

At around 300 MHz the log-periodic dipole array (LPDA) becomes attractive. Typically, these are used from 300 MHz to 1 GHz (and beyond, in many instances). The LPDA gives better VSWR and better directivity, on the order of <math>< 2.0:1</math> and 6 dBi, respectively. Because of the “infinite balun” design, the LPDA exhibits a very constant gain, over the entire frequency range. The constant gain and VSWR give the LPDA its characteristic, nearly constant increase in the antenna factors, which can be seen below. The upper frequency of the LPDA is limited in its bottom frequency due to the long elements. The upper frequency is limited by the fidelity of the connectors and smaller elements, as a practical concern.

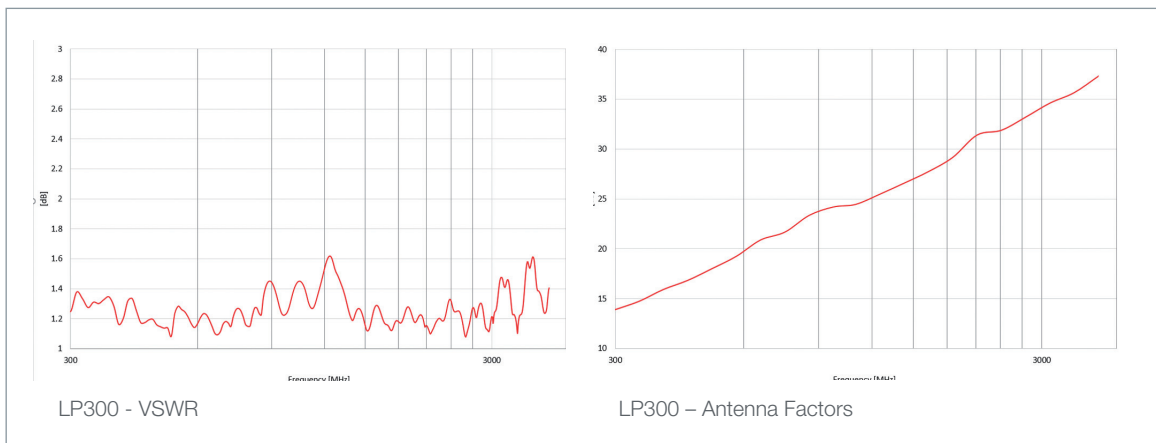
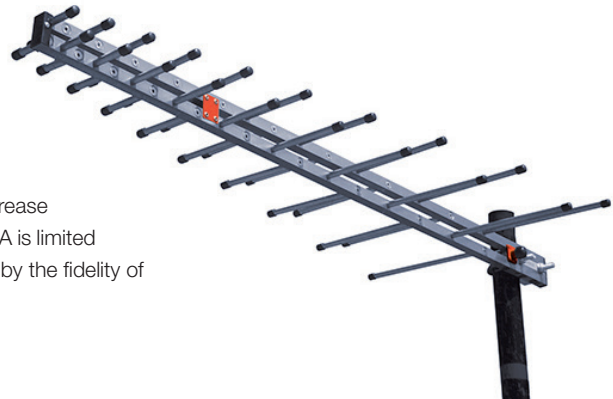

Hybrid antennas are popular because they can cover the entire frequency range (20 MHz to 1 GHz) with one antenna. Some hybrid antennas can operate up to 6 GHz and even 8 GHz. This can increase the testing throughput significantly. The hybrid antenna typically is constructed with some sort of a bowtie biconical combined with the log-periodic dipole array. The balance of these antennas is very crucial for optimum performance, especially when in the vertical polarization because of the proximity of the antenna to the ground plane (similar challenges to the biconical antennas). These antennas typically undergo the same balance test as the biconical antennas, comparing the antennas 180 degrees. Careful consideration needs to be taken to deal with the phase front and how it transitions from the bowtie dipole part of the antenna and onto the LPDA elements to the front of the antenna (that typically occurs in the 200 MHz to 300 MHz range). One wants to ensure the transition is smooth, as can be seen on the antenna factor curve.

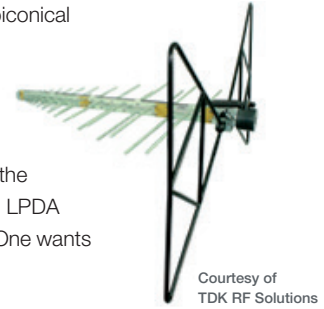

Courtesy of TDK RF Solutions

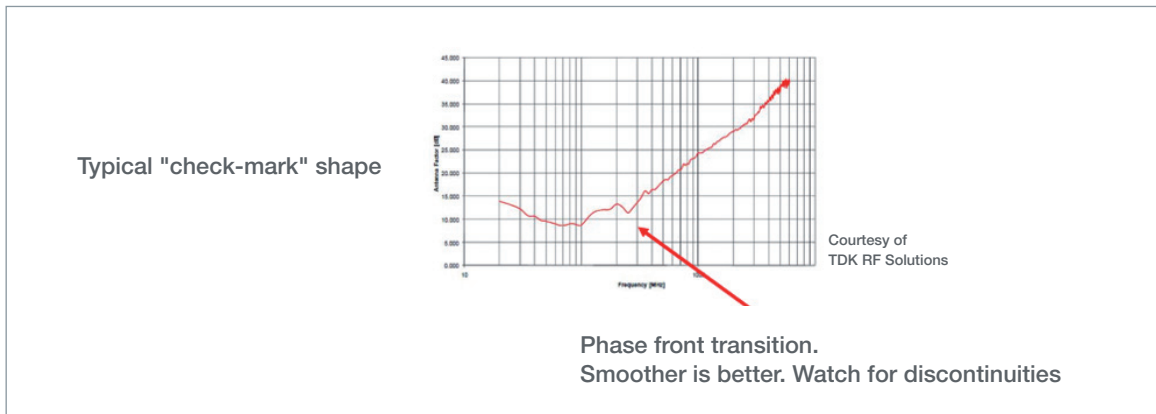

Another concern with the use of this antenna is the distance of the EUT from the antenna in the 20 MHz to 300 MHz range, when the phase front is located back on the biconical part of the antenna. As per the standards, the test distance is measured from the tip of the antenna (at the end of the LPDA part) to the EUT. Thus, at the lower frequency range, the distance from the phase front can be more than a meter greater than the specified testing distance (e.g., 3 m or 10 m). When using a standard biconical antenna, the distance from the antenna is measured from to the center of the caged elements, which means the phase front is approximately the same as the test distance. The "preferred antennas" in CISPR 16-1-4 is the use of the separate biconical and LPDA antennas because of its higher accuracy. Also, some automotive manufacturers prefer the use of the separate antennas to cover this frequency range. This is due to the smaller electrical size of the antenna and the better definition of the phase center.

At frequencies greater than 1 GHz, the preferred antenna is the dual-ridge horn. These antennas are used from 1 GHz to 6 GHz in the most common commercial testing scenarios, but this also can be used if testing needs to be extended to 18 GHz (or to 40 GHz) as described at the beginning of this paper.

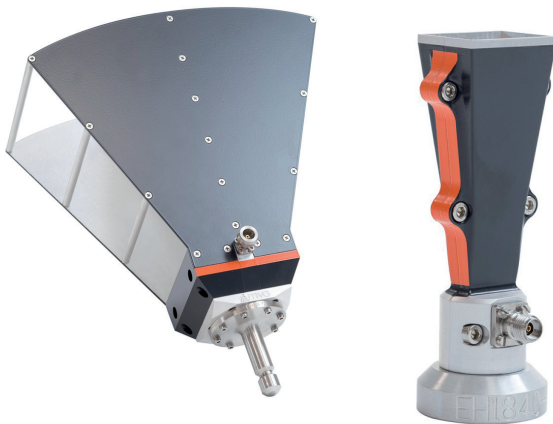

Dual-ridge horns offer greater directivity and gain; especially on-axis. This is useful at the upper frequencies where attenuation is greater, and where dynamic range is much more critical. The horns are typically used at closer distances. Even in a 10 m chamber, the EMI testing above 1 GHz is specified to be at a 3 m distance. Also, testing as per CISPR25 and MIL-STD-461, for benchtop automotive, and military standards, respectively, is at a 1 m distance.

The dual ridge horns provide a very stable pattern, at these shorter distances. The concern with the higher gain horn antennas is having a 3-dB beamwidth great enough to get the full coverage of the EUT under test. The higher the gain, the narrower the 3-dB beamwidth (and thus, the area of coverage. For example, at a 3 m test distance, the 3-dB beamwidth needs to be 28 degrees to cover a 1.5 m wide EUT. However, at a 1 m test distance, this same 28-degree beamwidth would only cover a 0.5 m wide EUT. Naturally, the directivity gets higher as the frequency gets higher, and one needs to take this into consideration when positioning the antenna in front of the EUT.

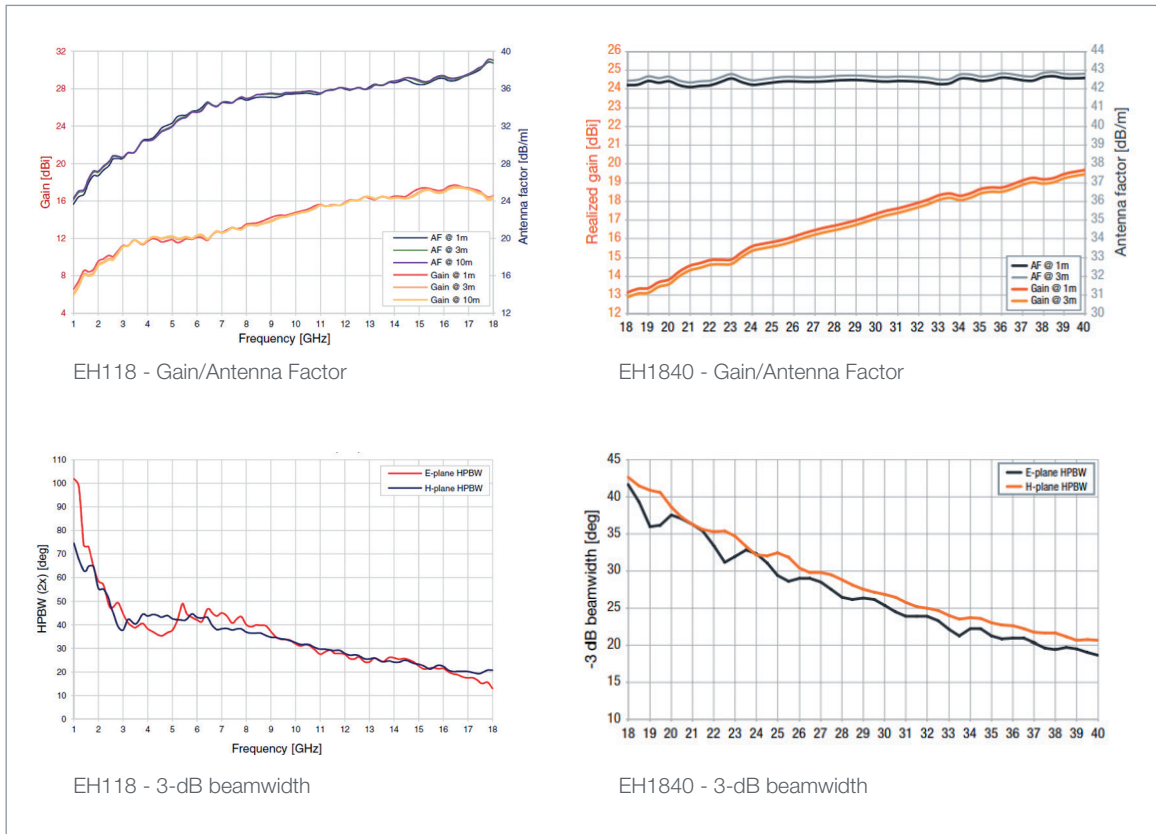

Most commercial standards specify EMI testing starting at 30 MHz as the lowest frequency, but there are a few industries whose standards specify testing procedures down to 9 kHz. One example is e.g., CISPR 11, which addresses Industrial, Medical, and Scientific products. Also, standards that govern products sold into the automotive industry or the military industry specify testing down to 9 kHz. The antennas used at these frequencies operate in the near-field, where either the electric field or the magnetic field dominates. Thus, the standards specify the use of a magnetic loop antenna or a vertical rod antenna, and in the vertical polarization, only. Most standards allow one or the other, though some standards, such as the CISPR 11 product standard, specify the use of a loop antenna only. In fact, CISPR 16-1-4, section 4.2 addresses emissions between 9 kHz and 150 kHz, and states that experience has shown that, in this frequency range, it is the magnetic field that is primarily responsible for observed instances of interference. For MIL-STD-461, both antennas may be required depending on the product and its application. As one can see, the antenna that is specified varies with the standard, and the industry, into which a product will be sold. Below is a general synopsis of which should be used, based on industry and standard:

- CISPR 16-1-4 & ANSI C63.4 – Both
- FCC/CISPR11/EN 302 291 - Loop Only
- Automotive – Rod Antenna
- MIL-STD-461/RE101 – Loop
- MIL-STD-461/RE102 – Rod Antenna



Courtesy of Com-Power



Courtesy of Com-Power

If one is using an antenna for use in a full-compliance EMI testing lab, then each of the antennas need to be calibrated properly. For most commercial EMI testing applications, the ANSI 63.5 (and the corresponding CISPR 16-1-6) is the most commonly used standard. It is, in fact, the “de facto” standard for governing the calibration of EMI antennas. It specifies calibrations at a 10 m distance, and for horizontal polarization only. One needs to have a correlation factor, or formula, for use with the biconical and LPDA antennas that correlate them to standard, tuned dipoles.

The dual-ridge horn antennas are typically calibrated at a 3 m distance (for use in EMI testing above 1 GHz). The antenna should be calibrated in the far-field, that is at a distance of $R \geq 2D^2/\lambda$. If an antenna is calibrated for a test distance less than in its far-field, that is a distance $R < 2D^2/\lambda$, then the antenna can ONLY be used at that test distance. Note, no calibration is valid if less than the test distance $R < 0.5D^2/\lambda$.

For test standards that specify testing at a 1 m distance, such as CISPR25 or MIL-STD-461, then SAE ARP 958 is the commonly used standard. It specifies calibration for horizontal polarization only, except for rod and loop antennas, which are calibrated in vertical polarization. Often, antennas that are calibrated at these distances are being used in the near-field and have a lot of ground plane interaction. Thus, it is important to have them calibrated in a configuration that is similar to how it will be used.

In summary, the design of and the use of antennas used for EMI testing must take into account many considerations for testing. The type of antenna used depends on the frequency range, the standard governing the industry into which the product will be sold, and practical concerns that make one antenna more attractive than another. Among the considerations when searching for the appropriate antenna are the frequencies and wide bandwidths, the small test enclosure (and short distance above the ground plane), and the short test distances. When considering an antenna, one must look for the proper balance (especially for biconicals or hybrids used over a ground plane), smooth antenna factor curves devoid of discontinuities, and 3-dB beamwidths to optimize performance.

Note: MVG specializes in antenna design and antenna measurements. Also, MVG has expertise and a wide range of products that enable companies to produce, test and certify their electrical and electronic products with greater accuracy and repeatability. MVG provides anechoic chambers, absorbing materials, antennas, and various products to perform EMC measurements and testing. You can read more about it at www.mvg-world.com/emc.

REFERENCES

- (1) C Paul, “Electromagnetic Compatibility,” 2nd Ed., pp 421-501, 2006
- (2) S Kron, “EMC Test Antennas – History, Design, and Construction,”
- (3) M. Montrose, “Testing for EMC Compliance,” 2004
- (4) CISPR 16-1-4, Edition 3.0 2017-01
- (5) CISPR 16-2-3, Ed2: 2006-2007
- (6) CISPR25, Edition 4.0 2016-10
- (7) MIL-STD-461G
- (8) ANSI C63.4a-2017
- (9) ANSI C63.5-2006
- (10) SAE ARP958D

MVG - Meeting the Testing Challenges of a Fully Connected World

The Microwave Vision Group (MVG) has developed unique expertise in the visualization of electromagnetic waves. These waves are at the heart of our daily lives: smartphones, computers, tablets, cars, trains, planes - these devices and vehicles would not work without them. MVG expertise brings measurement solutions to R&D teams for the characterization of antennas and their performance within these devices, and chamber solutions for EMC testing. MVG innovation remains focused on supplying the world with the most advanced EMF measurement technology to date.

WORLDWIDE GROUP, LOCAL SUPPORT

Our teams, in offices around the world, guide and support you from purchase, through design, to delivery and installation. Because we are local, we can assure speed and attention in project follow through. This includes customer support and maintenance once the system is in place. For the exact addresses and up-to-date contact information: www.mvg-world.com/mvg-offices



Contact your local sales representative for more information
www.mvg-world.com
salesteam@mvg-world.com