

ITEM

INTERFERENCE TECHNOLOGY ENGINEER'S MASTER



CELEBRATING
50 YEARS
OF PUBLICATION

education | support | community



Does your antenna supplier do *all* this?



	Your Supplier	A.H. Systems
Design / build their own?		✓
99% in stock now?		✓
Next day, on-time delivery?		✓
Over a hundred items to choose from?		✓
Portable antenna kits?		✓
Equipment still working after 40 years?		✓
Over 80 years of experience?		✓
Personal technical support?		✓
Personal Customer Service?		✓
Global support network?		✓

A.H. Systems does *all* of this, *all* of the time because we are the EMI test Antenna Specialists. We do not build “Boxes”. We do not build “Systems”. We do design and build the highest quality, most accurate EMI test antennas (20 Hz - 40 GHz).

It may be more convenient to buy everything from one supplier, but remember “Your test system is only as good as the antenna you put in front of it!”



Log Periodics
80 MHz - 7 GHz
13 Models

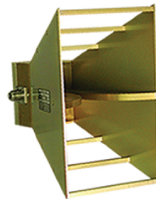

DRG Horns
170 MHz - 40 GHz
6 Models



All in one small package
20 Hz - 40 GHz



Biconicals
20 MHz - 18 GHz
7 Models

The Antenna Specialists



Innovation

Quality

Performance

Phone: (818)998-0223 ♦ Fax (818)998-6892
<http://www.AHSystems.com>

A.H. Systems



Exodus Engineering

Always Innovating



MILITARY applications

Ranging from HF to V bands, Exodus' military line of products cover LOS, SATCOM, Radar, Jamming, Telemetry, and Land Mobile Communication applications. Military line of products are ruggedized for harsh environmental usage & extended product life with enhanced controls for blanking operations. Light weight units are also available for avionic applications which are up to 50% lighter than equivalent commercial units.



EMC applications

Ranges from 10KHz to >40GHz, Exodus' EMC line of products offer solid state solutions to meet today's EMI/EMC requirements. Our Broadband solid state solution enables us to provide a better alternative solution to a TWTA which means extended product life and improved cost of ownership.



COMMERCIAL applications

Ranges from HF to V band, Exodus' commercial line of products cover industrial, scientific, medical, wireless, mobile, educational, commercial, avionic, and SATCOM applications. We provide cost competitive and industry leading packaging techniques for a superior product ownership experience.



Best in Class RF Amplifier SSPA's

“ With our in-house engineering capabilities and fully equipped manufacturing facilities, Exodus Advanced Communications is committed to provide the best RF products, leading in quality along with excellent lead times.

”

8KW+PULSE



www.exoduscomm.com



Exodus Advanced Communications

3674 E. Sunset Road, Suite 100

Las Vegas, Nevada 89120 USA

Tel : 1-702-534-6564

Email : sales@exoduscomm.com



LECTRIX

THERE'S ONLY ONE SPOTLIGHT

ARE YOU IN IT?



www.lectrixgroup.com

Problem first. Product last.

PHILADELPHIA | HONG KONG

4 | EDITORIAL

- 4 **Welcome to ITEM 2021**
James Marengo
- 5 **50 Years of ITEM**
Kenneth Wyatt
- 8 ***Interference Technology* Technical Editorial Board Members**
- 10 **Bob Goldblum "A Remembrance"**
Graham Kilshaw

12 | DIRECTORIES

- 12 **2021 EMC Suppliers Guide**
- 16 **2021 Test Lab Directory**
- 26 **EMC/EMI Consultants Directory**

28 | STANDARDS & ORGANIZATIONS

- 28 **Common Commercial EMC Standards**
- 32 **Medical EMC Standards**
- 33 **EMC Standards Organizations**

34 | REFERENCES & TOOLS

- 34 **Equations, Tools, Calculators**
- 38 **Common Symbols & Acronyms**
- 42 **Recommended EMC Books, Magazines & Journals**
- 44 **LinkedIn Groups**

45 | DESIGN FUNDAMENTALS

- 46 **EMC Equipment Manufacturers Matrix**
- 48 **Common Commercial, Automotive, Medical, Wireless & Military EMC Standards**
- 58 **References (Articles, Standards, Books, Mini Guides, Websites, & LinkedIn Groups)**
- 61 **What is the Most Important EMC Guideline?**
Marcel van Doorn
- 64 **Assembling a Low Cost EMI Troubleshooting Kit**
Kenneth Wyatt
- 64 **Part 1: Radiated Emissions**
- 71 **Part 2: Miscellaneous Additions and Immunity**

77 | EMC TESTING

- 78 **EMC Equipment Manufacturers Supplier Matrix**
- 80 **Common Commercial EMC Standards**
- 85 **References (Directory, Books, Organizations, LinkedIn Groups)**
- 87 **How to Prepare Your Product and Yourself for EMC Testing**
Ghery Pettit
- 92 **Summary of Commercial EMC Tests**
Ghery Pettit
- 96 **Developing an In-House EMC Troubleshooting and Pre-Compliance Test Lab**
Kenneth Wyatt



Chief Executive Officer

Graham Kilshaw

VP of Marketing

Geoffrey Forman

Editorial Director

James Marengo

Creative Director

Christopher Bower

Business Development Director

Janet Ward

Production Coordinator

Jessica Stewart

Lead Graphic Designer

Kate Teti

Administrative Manager

Eileen M. Ambler

Accounting

Susan Kavetski

LECTRIX

USA

1000 Germantown Pike, F-2
Plymouth Meeting, PA 19462
Phone: (484) 688-0300
Fax: (484) 688-0303
E-mail:

info@interferencetechnology.com
www.interferencetechnology.com

CHINA, TAIWAN, HONG KONG

ACT International
Mainland China - Linda Li, +86-21-62511200
Email: lindaL@actintl.com.hk
Hong Kong - Mark Mak, +85-22-8386298
Email: markm@actintl.com.hk

JAPAN

e-OHTAMA, LTD.
Masaki Mori, +81-3-6721-9890
Email: masaki.mori@ex-press.jp

LECTRIX endeavors to offer accurate information, but assumes no liability for errors or omissions. Information published herein is based on the latest information available at the time of publication. Furthermore, the opinions contained herein do not necessarily reflect those of the publisher.

Copyright © 2021 • LECTRIX • ISSN 0190-0943

- 99 Military Related Documents & Standards
- 101 Automotive Electromagnetic Compatibility (EMC) Standards

105 | FEATURED INDUSTRIES

105 WIRELESS/5G/IoT EMC

- 106 Wireless & IoT EMC Suppliers Matrix
- 108 Wireless Groups & Organizations
- 110 References (Groups, Websites, Books, Formulas & Tables)
- 113 PC Board Design for Wireless Products
Kenneth Wyatt
- 121 Identifying and Locating Radio Frequency Interference (RFI)
Kenneth Wyatt
- 127 Cost Effectively Ensure Electromagnetic Compatibility
in the Age of IoT
Matthew Maxwell

134 AUTOMOTIVE EMC

- 135 EMC Equipment Manufacturers Matrix
- 137 References (Test Labs, Groups, Publications, & LinkedIn Groups)
- 139 Top Three EMI and Power Integrity Problems with On-Board DC-DC Converters and LDO Regulators
Kenneth Wyatt | Steve Sandler
- 145 Five Steps for Successful Automotive EMC Design
Sreevas P Vasudevan | Praveen S Mohan
- 150 Resilience is Key to the Connected and Autonomous Revolution
Anthony Martin

155 MILITARY/AEROSPACE EMC

- 156 EMC Equipment Manufacturers
- 158 References (Article Links, Directories, Conferences, & LinkedIn Groups)
- 159 Table of New Equipment Allowed/Required in MIL-STD-461G
Tony Keys | Ken Javor
- 161 Military Related Documents and Standards
- 163 Summary of Military and Aerospace EMC Tests
Ghery Pettit
- 169 Review of MIL-STD 461 CS117 Lightning Induced Transients, Cables and Power Leads
Steve Ferguson

172 | INDEX OF ADVERTISERS

FREE SUBSCRIPTIONS

ITEM, Interference Technology — is distributed annually at no charge to engineers and managers engaged in the application, selection, design, test, specification or procurement of electronic components, systems, materials, equipment, facilities or related fabrication services. Subscriptions are available through www.interferencetechnology.com.



WELCOME TO ITEM 2021

JAMES MARENGO

For 50 years, Interference Technology (and ITEM Media before that) has provided engineers with the information they need to conquer always-prevalent EMI issues. With articles, reference guides, directories, and standards information, ITEM has been designed to serve as a comprehensive guide for all things EMC.

The tradition continues with our latest edition; ITEM 2021 features articles and content across major markets:

- Design Fundamentals
- Testing Fundamentals
- Wireless/5G/IoT EMC
- Automotive EMC
- Military/Aerospace EMC

Not only do deep-dive technical articles provide key considerations for product design, ITEM 2021 also offers engineers the opportunity to quickly find contact information for a test lab. After all, ITEM stands for Interference Technology Engineer's Master. Having all this information in one place that is easy to refer to will be invaluable to anyone in the world of EMI and EMC.

Ultimately, ITEM is designed to best serve our readers by providing a comprehensive resource for the EMC community. Without your support and engagement, none of this would be possible, and we thank you for joining us in celebrating 50 years of service!

We hope you enjoy reading ITEM 2021.



50 YEARS OF ITEM

KEN WYATT

Interference Technology Engineers Master (ITEM) has turned 50 this month and is the longest published periodical dealing specifically with electromagnetic compatibility. Started by Robert Goldblum, R & B Enterprises, in 1971 as an annual compilation of the latest ideas and testing techniques in EMC with articles by some of the greatest EMC legends.

My dad was an electronics engineer and I became enamored with electronics at an early age. When ITEM started publishing, I was attending the University of California - Irvine as a biological sciences major, but with a continuing passion for electronics. Dad received one of the first sample issues and I subscribed a year later, impressed with all the technical articles with filter design and impedance response curves. Some articles were saved for later study. I later earned my EE degree.

At the time I subscribed, I didn't have a clear picture of EMC or what it meant, let alone would I have imagined going into the field full time! I never would have thought that 45 years later, I'd be serving as senior technical editor!

While I didn't keep too many of those old back issues, I know several engineers who had good collections. One of those was Edward Price, who spent most of his engineering career at General Dynamics and Cubic Electronics in San Diego. During the time I was editing the magazine, Ed shipped me a box full of older back issues, with the earliest dated 1974, just after I first started subscribing.

Some of the earliest articles in the 1970s were merely reprints from various sources. Some early authors included Ed Wetherhold (Honeywell), William Duff (Atlantic Research Corp), Robert Goldblum (R&B Enterprises), Richard Schultz (IIT Research Institute), Don White (Don White Consultants), Hugh Denny (Georgia Tech), William Bakker (Breeze-Illinois), Charles Anderson (ITEM staff), and Herbert Mertel (EMACO EMC Consultants). Major advertisers included Singer, Andy Hish, Elite Electronics, Electro-Metrics, Instruments For Industry, Lectro Magnetics, Pearson, Rohde & Schwarz, Solar Electronics, Don White Consultants, Chomerics and Instrument Specialties.

In the 1980s, some authors included William Curran (Lindgren), John Broderick (Chomerics), Glen Dash (Dash, Straus & Goodhue), Stephen Halperin (Stephen Halperin & Assoc), and Edwin Bronaugh (Electro Metrics). The number of



Figure 1 - Robert Goldblum, publisher emeritus, and Kenneth Wyatt, senior technical editor of Interference Technology taken during the IEEE Symposium on EMC in Ottawa (2017).



Figure 2 - A sampling of back issues from 1974 through 2008.



Figure 3 - Janet Ward, marketing manager, and Graham Kilshaw, publisher of ITEM Media, attending the IEEE Symposium on EMC in Long Beach, August 2018.

advertisers had doubled and major ones included A. H. Systems, Amplifier Research, D.L.S. Systems, EMACO, Fair-Rite, Fischer Custom Communications, Hewlett-Packard, Keytek, Lindgren RF Enclosures, 3M, Ray Proof, Tech-Etch and Zippertubing.

Noteworthy, in October 1984, the FCC established the new Sampling and Measurements Branch, to be directed by Art Wall. This new organization would be the enforcement arm for the Commission's regulations and was responsible for sampling production units of consumer electronics and other electronic devices. This largely came about following innumerable complaints to the FCC of television and radio interference from the early personal computers introduced in the late 1970s - primarily, the popular Radio Shack TRS-80. This event only accelerated the need for EMC design and test information, for which ITEM took an early lead.

By the 1990s, authors included George Kunkel (Spira Manf), Mark Nave (EMC Services), Herbert Mertel (now Mertel Assoc) and many more. By then the publication had added color and slick pages. Major new advertisers included EMCO, Lindgren, RayProof, FerriShield, Quad Design (one of the early EM simulators), Steward, Chase, Schaffner, CKC and a host of newer companies now meeting the needs of designers.

By the 2000s ITEM was rebranded as ITEM - Interference Technology and continued with color and slick pages. Authors included David Case (Cisco), Kermit Phipps (EPRI EMC Lab), Dr. William Radasky (Metatech Corp), Dan Hoolihan (Hoolihan EMC Consulting), Gary Fenical (Laird), Lee Hill (Silent Solutions), Ron Brewer (EMC Consultant), Mart Coenen (EMCMCC BV), Bruce Archambeault (IBM) and Tony DiBiase (Spec-Hardened Systems). Major new advertisers included ARC Technologies, Com-Power, CST, ETS-Lindgren, Gore, HV Technologies, Intertek, Kikusui, Leader Tech, Liberty Labs, Murata, Oak-Mitsui, Sunol Sciences, TDK, Teseq, Thermo Fisher, TÜV and UL.

Robert later retired and turn over the publication to Graham Kilshaw, who hired me in 2016. As I'd been writing for various publications since my college days, it was quite interesting to learn the publishing field from "the other side". It was a fantastic opportunity and I enjoyed the three years I served editing the annual ITEM, plus all the spin-off design guides on various topics.

Graham came over from Disney Engineering and after marrying Robert Goldblum's daughter, Rebecca, he took over publishing duties in 2003. Under my term as editor, we expanded the annual ITEM publication (now called the EMC Directory & Design Guide) to include smaller on-line publications addressing different market segments, such as Automotive, Military & Aerospace, EMC Test, EMC Fundamentals, EMC Components, Filters and Shielding. We also initiated an annual EMC Test & Design Guide and a Europe EMC Guide, translated into several languages.

It's been a fun ride with ITEM and I'm happy they've managed to bring EMC education to working engineers for 50 years!



We're with you all the way

rf/microwave instrumentation

Other ar companies: modular rf • sunar rf motion • ar europe

Everything you need for **EMC Testing**.



From **complete testing systems** to **software, anechoic chambers** and **shielded rooms**, AR is your one stop for **EMC testing**.

All of our testing solutions are built to last and come with the product quality and high level support customers can expect from AR.

For more information on AR Amplifiers visit us at www.arworld.us/systems or call 215-723-8181.

INTERFERENCE TECHNOLOGY TECHNICAL EDITORIAL BOARD MEMBERS



DAVID A. WESTON
iNARTE EMC ENGINEER

David A. Weston is an electromagnetic compatibility (EMC) consultant and certified National Association of Radio and Telecommunications Engineers (iNARTE) EMC engineer at EMC Consulting Inc. Merrickville, Ontario, Canada. A life member of the Institute of Electrical and Electronics Engineers, Weston has worked in electronic design for 55 years, specializing in the control, prediction, measurements, problem solving, analysis, and design aspects of EMC for the last 44 years.

He is the author of the third edition of the 1,157-page book *Electromagnetic Compatibility, Methods, Analysis, Circuits, and Measurement* published by CRC press in 2017, as well as numerous papers of a practical nature.



GHERY PETTIT
PRESIDENT, PETTIT EMC CONSULTING LLC

Ghery S. Pettit received the BSEE degree from Washington State University in 1975. He has worked in the areas of TEMPEST and EMC for the past 44 years. He was with the Naval Electronic Systems Engineering Center, Vallejo starting in 1976. In 1979 he joined Martin Marietta Denver Aerospace where he worked on what became the Peacekeeper missile system, as well as other projects, providing TEMPEST and EMC design and analysis support. In 1983 he joined Tandem Computers in

Cupertino, California providing EMC design, troubleshooting and EMC compliance testing services to a number of projects and oversaw the construction of Tandem's 30 meter Open Area Test Site (OATS) and 10 meter RF semi-anechoic chamber. In 1995 Ghery joined Intel Corporation where he was involved in the construction of EMC test facilities, providing design guidance and troubleshooting support to various projects and representing Intel on a number of industry committees and national and international standards bodies. Since retiring from Intel in 1995 he is now continuing his work on national and international standards development organizations and consulting in the areas of EMC design, troubleshooting, testing, standards interpretations and laboratory design.

Mr. Pettit is presently serving as Chair of CISPR SC I and is one of CISPR's representatives on the Advisory Council on EMC (ACEC) within the IEC. He has been involved in CISPR activities since 1998, both as a member of the US Technical Advisory Groups to CISPR SC G and CISPR SC I and as an active member of CISPR SC I and its maintenance teams, CISPR SC I MT7 (CISPR 32 maintenance) and CISPR SC I MT8 (CISPR 35 maintenance). He is also a member of the US TAG for IEC SC77B and the working group preparing the next edition of ANSI C63.4.

Ghery has written 8 papers and articles for publication and contributed a chapter for the 2nd and 3rd Editions of the ARRL's *Radio Frequency Interference Handbook*. He is a member of the dB Society and serves as a Technical Advisor for the ARRL in the area of EMC. He holds an Amateur Extra radio license and is an instrument rated private pilot.



MIKE VIOLETTE
iNARTE CERTIFIED EMC ENGINEER

Mike is President of Washington Laboratories and Director of American Certification Body. He has over 35 years of experience in the field of EMC evaluation and product approvals and has overseen the development of engineering services companies in the US, Europe and Asia. Mike is currently on the Board of Directors of the IEEE EMC Society.

He is a Professional Engineer, registered in the State of Virginia. He has given numerous presentations on compliance topics and is a regular contributor to technical and trade magazines.

INTERFERENCE TECHNOLOGY TECHNICAL EDITORIAL BOARD MEMBERS



PATRICK ANDRE

iNARTE CERTIFIED MASTER DESIGN ENGINEER

Patrick G. André received his physics degree in 1982 from Seattle University, with post graduate work in Electrical Engineering and Physics. He has worked in the Electromagnetic Compatibility (EMC) field over 35 years. He is an iNARTE Certified Engineer in both EMC (Electromagnetic Compatibility – EMC-001335-NE) and ESD (Electrostatic Discharge – ESD-00078-NE). He was honored as an iNARTE Certified Master Design Engineer - EMCD-00053-ME.

He has worked in the military and aerospace environment for his entire career and worked with commercial electronics for over 25 years. Projects worked on vary from semiconductors, satellite equipment, industrial and test equipment, cellular installations, to writing the procedures and reports, and performing or supervising EME testing of many panels for the flight deck of several aircraft. He has successfully worked with, and given input to, all branches of the military, NASA, the RTCA, the FAA, as well as several of their subcontractors. He has a strong ability in the test, measurement, and troubleshooting of EMC, and is president of André Consulting, Incorporated.

He is a third-party auditor for local governments and has provided expert opinions on the use of cellular transmitters, including health and safety concerns. Patrick has published numerous articles for a variety of magazines. He is the coauthor of EMI Troubleshooting Cookbook for Product Designers.

Patrick has been a senior member of the IEEE EMC Society which he joined in 1984, serving as chairman, vice chairman, secretary, and arrangements chairman of the Puget Sound Section, and has received The Legends of the IEEE Seattle Section Award in 2010. He also been on the Board of Trustees of the Seattle Gilbert and Sullivan Society where he also works as the sound engineer and. He enjoys audio and video recording musical groups, mostly in the Seattle area, and has engineered and mastered several CD's. And when he is not busy with all this, he can be found hiking somewhere with his camera.



STEVE FERGUSON

OWNER, COMPLIANCE DIRECTION, LLC | iNARTE EMC ENGINEER

Steven G. Ferguson is the owner of Compliance Direction, LLC and has been working in the compliance test arena for over 40 years at test laboratories and manufacturing companies designing products, developing procedures and performing tests. He presents various courses on EMI/EMC compliance including EMC for Nuclear Power Facilities, Architectural Shielding, Environmental qualification and MIL-STD-461 & DO-160 testing at customer facilities on-site for multiple government and industrial clients. He is versed on Electrical Safety evaluations including Risk Analysis for medical and information technology equipment. He holds an iNARTE EMC engineer certification. Contact him at stevef@compliancedirection.com

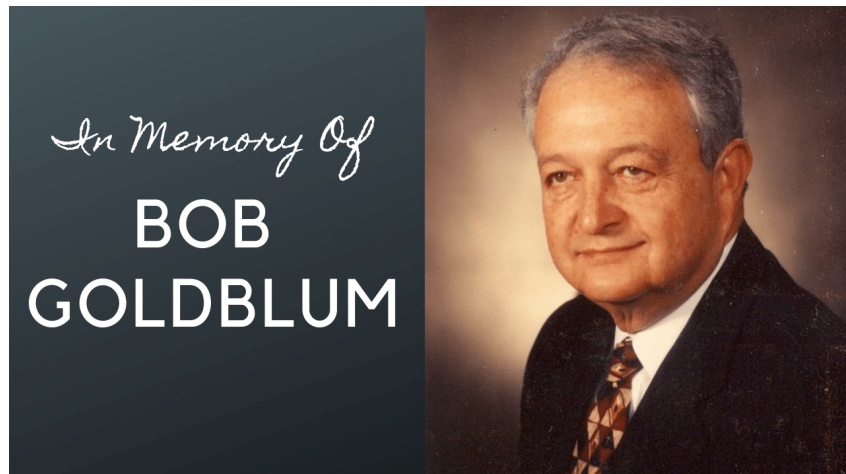

Robert "Bob" Goldblum 1935 - 2019

In honor of ITEM's 50th anniversary, we're re-running Interference Technology's creator and founder Bob Goldblum's memoriam that originally appeared in ITEM 2020. Through Bob's vision and direction, ITEM became an industry standard and essential piece of the EMC community.

In May 2019, the world of EMC lost a "key player"—Bob Goldblum. He was one of the first in the industry and helped to build the EMC community into what it is today. Even in retirement, he never stopped giving back to it, primarily through writing, mentorships, and friendships. He founded this publication, *Interference Technology* (aka *ITEM*) in 1971, and in 1999, he passed the reins to me. So, for me, I lost not only a father-in-law, but also a mentor and the guy who gave me a shot at the thing I wanted most in my career—the chance to run a company. At his funeral, I had the immense privilege to write and deliver his eulogy, which follows here. I'm sure Bob the editor would have had a few edits, but I'm also sure that Bob the friend and father-in-law would have liked it.

My name is Graham Kilshaw and it is my honor to offer this eulogy in honor of my father-in-law, Bob Goldblum.

It was only 35 degrees outside when Bob was born, December 18, 1935 in Philadelphia, and the economy wasn't that warm either. After all, most of the country was considered far from comfortable at that time. The Wall Street Crash had occurred just six years prior, and the effects of Roosevelt's New Deal were only just beginning to show.

So like many, Bob's parents, Harry and Rose Goldblum, were not wealthy. From those humble beginnings (Bob even remembered making ketchup sandwiches for lunch), he went on to become the epitome of the self-made man.

After repeating a year and finally graduating high school in West Philadelphia, he joined the U.S. Air Force in 1954, and became a Radar Technician, which initiated his lifelong love of electronics. Taking advantage of the Korean War G.I. Bill, he went to Penn State University. I seem to remember Bob once telling me that he ultimately earned three things from Penn State:

A BSEE

An MSEE

And a BFG—his wife of over 50 years, Barbara, also a graduate of Penn State.

Like many new graduates, Bob's early career gained him valuable experience in his chosen field of electronics engineering. He worked at ARK in Willow Grove, Sylvania in Mass., and AEL in Lansdale.

Even by this early stage, Bob was already a recognized specialist in the new, emerging field of electromagnetic interference (EMI), but this EMI thing was no esoteric, weird subject even if it seemed that way to some.

In the late 1960s the world was beginning to fill with electronics of all kinds—in our houses and homes, in our cars, in offices and factories, and most critically in the field of military electronics. And interference was everywhere. So, it's no exaggeration to say that Bob Goldblum, along with a relatively small group of other brilliant young engineers at that time, made sure that our world of technology today all works together successfully and safely.

While working at GE in King of Prussia around '68 on military and space projects, he helped to safely launch some of the early satellites; he helped to bring some of the monkey space flights safely back to earth; he helped to design safe systems for the Minuteman missile program and the underground nuclear tests in the Nevada desert at that time.

After a while, he realized that this new field of EMI needed a publication—and that he was the guy to do it. And so, in 1971, he started what ultimately became highly recognized as *ITEM*—the *interference technology* publication.

Many great businesses start in a garage; this one started in the family's spare bedroom in Plymouth Meeting, until my wife Becky was born. And then Bob was kicked out into the garage. Family members stuffed envelopes with magazines, kids attached stamps and address labels, friends edited articles, printers gave him credit to get started, and a business was born.

Little did he know at the time that the publication would lead to connections with hundreds of companies looking for help in this new emerging field. And so, by 1974, he was ready to leave GE to form yet another new business: offering consulting and engineering services to solve the increasing electronic interference problems in the world.

Working in a 400 square foot office above a local restaurant, Bob formed "Robert and Barbara Enterprises", aka R&B Enterprises, which comprised both the engineering business and the publishing company. It's a great testament to Bob's first-to-market vision that both of those businesses continue to thrive today.

When you look around your world today, you wouldn't know that so many of our electronics work because of his contributions.

He once described to me, after the British destroyer HMS Sheffield was sunk during the Falklands War in 1982, how he helped to solve the interference problem that caused that fateful attack. He once appeared in a New York courtroom, when the New York Times was wrongly accused by the typesetters' union of the newspaper's computers giving them cataracts. He worked on some really fascinating world-scale problems throughout his life.

But for Bob it wasn't just about creating a successful business or career, he truly loved what he did. And, he knew he was solving problems that affected the real world. Bob was an engineer, a teacher, a publisher, a writer, an entrepreneur, a speaker, an event producer...even an early video producer. The early video he produced on the subject was adopted by governments all around the world as one of their key training tools.

He was recognized and admired as a thought leader and an industry pioneer. He launched training companies, acquired an Israeli company, started a testing lab and yet still helped others to launch their own businesses along the way. He trained thousands of government and military employees from the U.S., NATO, South Africa, India, and Israel on how to solve interference problems that would ultimately save many, many lives.

He helped to create the society that built an entire industry—the EMC Society. He was the society's newsletter editor for 30 years, and was a lifelong member; he received numerous prestigious awards honoring his contributions to technology in the world today. But if you asked him, he would always credit those around him—his employees at R&B Enterprises, his mentors, his colleagues in the field, his friends, and the opportunities he was given—but rarely himself. Like I said, he truly loved what he did.

He once said in an interview that he "never considered himself a good businessman...." I can tell you as the young guy to whom he gave the opportunity of a lifetime 20 years ago that nothing could be further from the truth. Bob and Barbara—my family and I owe you a debt of gratitude for my own career. Bob, I'll always remember two simple things you taught me: "*There has to be a need for what you do*" and "*Guide your people well and then get out of their way.*"

Thanks for everything Bob. I'll miss you....

Graham Kilshaw
Publisher – *Interference Technology*, CEO - Lectrix

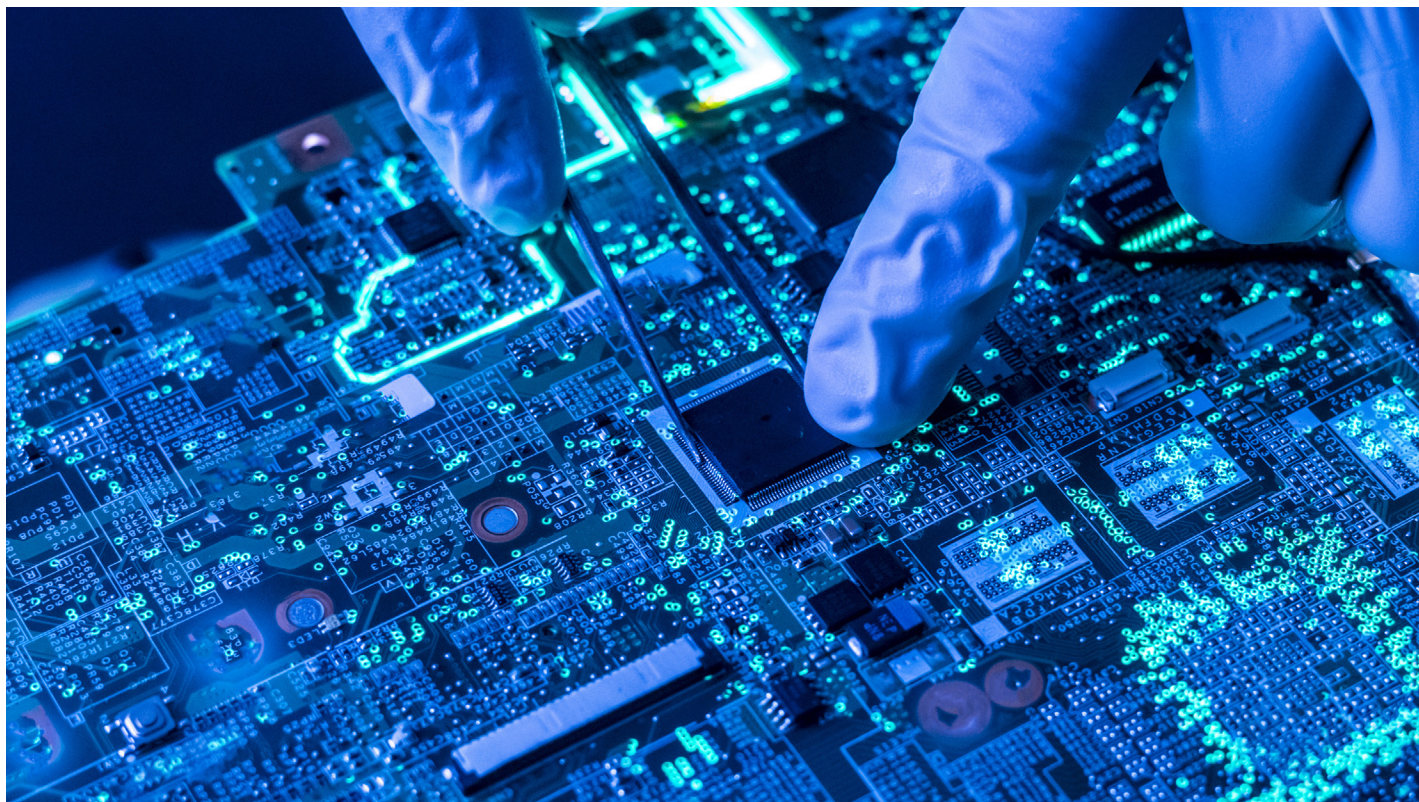

2021 EMC SUPPLIER GUIDE

In this section, we provide a quick guide to some of the top suppliers in each EMC category - test equipment, components, materials, services, and more. To find a product that meets your needs for applications, frequencies, standards requirements, etc., please search these individual supplier websites for the latest information and availability. If you have trouble finding a particular product or solution, email james@lectrixgroup.com for further supplier contacts.

COMPANY	WEBSITE	AMPLIFIERS	ANTENNAS	CABLES & CONNECTORS	CERTIFICATION	CONSULTANTS	COMPONENTS	DESIGN / SOFTWARE	EMI RECEIVERS	FILTERS / FERRITE'S	LIGHTNING & SURGE	MEDIA	SEALANTS & ADHESIVES	SHIELDING	SHIELDED ROOMS	SPECTRUM ANALYZERS	TEST EQUIPMENT	TEST EQUIPMENT RENTALS	TEST EQUIPMENT OTHER	TESTING	TESTING LABORATORIES	TRAINING SEMINARS & WORKSHOPS
			AH SYSTEMS, INC. t: (818) 998-0223 e: sales@ahsystems.com w: www.ahsystems.com	X	X	X													X	X	X	
	COILCRAFT t: (800) 322-2645 e: sales@coilcraft.com w: www.coilcraft.com						X		X													
	SPIRA Manufacturing Corporation t: (818) 764-8222 e: info@spira-emi.com w: www.spira-emi.com													X								

COMPANY		WEBSITE	AMPLIFIERS	ANTENNAS	CABLES & CONNECTORS	CERTIFICATION	CONSULTANTS	COMPONENTS	DESIGN / SOFTWARE	EMI RECEIVERS	FILTERS / FERRITE'S	LIGHTNING & SURGE	MEDIA	SEALANTS & ADHESIVES	SHIELDING	SHIELDED ROOMS	SPECTRUM ANALYZERS	TEST EQUIPMENT	TEST EQUIPMENT RENTALS	TEST EQUIPMENT OTHER	TESTING	TESTING LABORATORIES	TRAINING SEMINARS & WORKSHOPS	
A	Aaronia AG	www.aaronia.com	X	X						X							X							
	Advanced Test Equipment Rentals (ATEC)	www.atecorp.com	X	X		X				X		X			X	X	X	X	X	X	X			
	AH Systems, Inc.	www.ahsystems.com	X	X	X													X	X	X				
	Altair- US	www.altair.com					X		X															
	American Certification Body Inc.	https://acbcert.com/				X	X		X													X	X	X
	Ametek- CTS Compliance Test Solutions	www.ametek-cts.com	X	X														X		X				X
	Anritsu Company	www.anritsu.com		X													X	X		X	X			
	API Technologies	www.apitech.com						X			X													
	AR RF/Microwave Instrumentation	www.arworld.us	X	X	X				X							X	X		X	X				
	Astrodyne	www.astrodyneTDL.com									X													
B	Beehive Electronics	www.beehive-electronics.com																				X		
C	Captor Corporation (EMC Div.)	www.captorcorp.com								X														
	Coilcraft	www.coilcraft.com						X		X														
D	CPI- Communications & Power Industries (USA)	www.cpii.com/emc	X																					
	Dassault System Simulia Corp	www.3ds.com/							X															
	Delta Electronics (Americas) Ltd.	www.delta-americas.com								X														
	DLS Electronic Systems, Inc.	www.dlsemc.com																					X	
E	Electro Rent	www.electrorent.com	X							X				X			X		X					
	Elite Electronic Engineering Co.	www.elitetest.com																					X	
	EMC Live	www.emc.live																						X
	EMC Partner	www.emc-partner.com																X						
	Empower RF Systems, Inc.	www.empowerrf.com	X																					
	EM TEST USA	www.emtest.com																X						
	Exemplar Global (iNarte)	www.exemplarglobal.org																						X
	EXODUS Advanced Communications	www.exoduscomm.com	X	X	X													X						
F	F2 Labs	www.f2labs.com				X	X															X	X	X
	Fischer Custom Communications	www.fischercc.com																		X				
	Frankonia Solutions	www.frankonia-solutions.com													X	X		X					X	

COMPANY		WEBSITE		AMPLIFIERS	ANTENNAS	CABLES & CONNECTORS	CERTIFICATION	CONSULTANTS	COMPONENTS	DESIGN / SOFTWARE	EMI RECEIVERS	FILTERS / FERRITE'S	LIGHTNING & SURGE	MEDIA	SEALANTS & ADHESIVES	SHIELDING	SHIELDED ROOMS	SPECTRUM ANALYZERS	TEST EQUIPMENT	TEST EQUIPMENT RENTALS	TEST EQUIPMENT OTHER	TESTING	TESTING LABORATORIES	TRAINING SEMINARS & WORKSHOPS	
G	Gauss Instruments	www.gauss-instruments.com								X								X							
	Gowanda Electronics	www.gowanda.com							X																
H	Haefely	www.haefely.com								X									X			X			
	Heilind Electronics, Inc	www.heilind.com										X													
	Henry Ott Consultants	www.hottconsultants.com						X																	
	HV TECHNOLOGIES, Inc.	www.hvtechnologies.com		X	X						X		X				X	X	X		X				
I	Instrument Rental Labs	www.testequip.com		X							X							X		X					
	Interference Technology	www.interferencetechnology.com																						X	
	Intertek	www.intertek.com																						X	
	ITG Electronics, Inc.	www.itg-electronics.com							X			X													
K	Keysight Technologies	www.keysight.com/us/en									X							X		X	X				
	Krieger Specialty Products	www.kriegerproducts.com															X								
L	Laird Electronics	www.lairdtech.com/										X			X										
	Langer EMV-Technik	www.langer-emv.de/en/index																				X			
M	Magnetic Shield Corp.	www.magnetic-shield.com														X									
	Master Bond Inc.	www.masterbond.com													X										
	MBP Srl	www.mbp.it/en/								X											X				
	Microlease	www.microlease.com		X							X							X		X					
	MILMEGA	www.ametek-cts.com		X																					
	Montrose Compliance Services	www.montrosecompliance.com						X																	
	MVG Microwave Vision Group	www.mvg-world.com			X							X					X	X							
N	Narda Safety Test Solutions	www.narda-sts.com		X	X						X							X			X				
	Noise Laboratory Co., Ltd.	www.noiseken.com																						X	
	NTS	www.nts.com																					X		
O	Ophir RF	www.ophirrf.com		X																					
P	Parker Chomerics	www.chomerics.com														X									
	Pearson Electronics	www.pearsonelectronics.com							X																
	PPG Cuming Lehman Chambers	www.cuminglehman.com														X	X						X		
	PPG Engineering Materials	www.dexmet.com														X									
	Prana	www.prana-rd.com		X																					
	Pulse Power & Measurement Ltd	https://ppmtest.com/																				X			
Q	Quell Corp.	www.eeseal.com				X						X	X									X			

COMPANY		WEBSITE	AMPLIFIERS	ANTENNAS	CABLES & CONNECTORS	CERTIFICATION	CONSULTANTS	COMPONENTS	DESIGN / SOFTWARE	EMI RECEIVERS	FILTERS / FERRITE'S	LIGHTNING & SURGE	MEDIA	SEALANTS & ADHESIVES	SHIELDING	SHIELDED ROOMS	SPECTRUM ANALYZERS	TEST EQUIPMENT	TEST EQUIPMENT RENTALS	TEST EQUIPMENT OTHER	TESTING	TESTING LABORATORIES	TRAINING SEMINARS & WORKSHOPS	
R	Radiometrics	www.radiomet.com																					X	
	R&B Laboratory, Inc.	www.rblaboratory.com																					X	
	Retlif Testing Laboratories	www.retlif.com																			X	X	X	
	RIGOL Technologies	www.rigolna.com	X					X									X	X		X				
	R&K Company Limited	www.rk-microwave.com	X					X																
	Rohde & Schwarz GmbH & Co. KG	www.rohde-schwarz.com/de	X	X						X					X	X	X	X						
	Rohde & Schwarz USA, Inc.	www.rohde-schwarz-usa.com	X	X						X					X	X	X	X						
S	Schaffner EMC, Inc.	www.schaffner.com						X		X											X	X		
	Schurter, Inc.	www.schurter.com			X					X														
	Schwarzbeck Mess-Elektronik	www.schwarzbeck.com		X																				
	Select Fabricators	www.select-fabricators.com													X	X								
	Siglent Technologies	www.siglentna.com																X						
	Signal Hound	www.signalhound.com						X	X								X				X			
	Solar Electronics	www.solar-emc.com		X																				
	Spira Mfg. Corp.	www.spira-emi.com													X									
	T	TDK	www.tdk.com						X		X						X							X
Tektronix		www.tek.com																X						
Teledyne LeCroy		www.teledynelecroy.com																X						
TESEQ Inc.		www.teseq.com																X						
Test Equity		www.testequity.com/leasing/	X							X							X		X					
Thurlby Thandar (AIM-TTi)		www.aimtti.com								X							X							
Toyotech (Toyo)		www.toyotechus.com/emc-electromagnetic-compatibility/	X	X						X							X							
TPI		www.rf-consultant.com						X																
Transient Specialists		www.transientspecialists.com																		X				
TRSRenTelCo		www.trsrntelco.com/categories/spectrum-analyzers/emc-test-equipment	X	X						X								X	X	X		X		
V	Vectawave Technology	www.vectawave.com	X																					
	V Technical Textiles / Shieldex US	www.vtechtextiles.com													X									
W	Washington Laboratories	www.wll.com				X	X	X			X										X	X	X	
	Windfreak Technologies	www.windfreaktech.com																X			X			
	Würth Elektronik eiSos GmbH & Co. Kg	www.we-online.com		X	X			X	X	X	X				X									
	Wyatt Technical Services	www.wyatt-tech.net					X																X	
X	XGR Technologies	www.xgrtec.com													X									

2021 EMC TEST LAB DIRECTORY

WHEREVER YOU ARE IN THE COUNTRY you now have access to local testing facilities. We have created an easy-to-use directory of national labs and their services grouped alphabetically by state and city, so that our readers can identify labs closest to them. We have strived to make this directory as accurate as possible; our goal is to have the most concise, informative, and up-to-date information. E-mail any additions, revisions, and suggestions to james@lectrixgroup.com.

USA			BELLCORE/TELCORDIA	CB/CAB/TCB CB/CAB/TCB	EMISSIONS	EMP/LIGHTNING EFFECTS	ESD	EURO CERTIFICATIONS	FCC PART 15 & 18	FCC PART 68	IMMUNITY	LIGHTNING STRIKE	MIL-STD 188/125	MIL-STD 461	NVLAP/AZLA APPROVED	PRODUCT SAFETY	RADHAZ TESTING	RS103 > 200 V/METER	REPAIR/CALIBRATION	RTCA DO-160	SHIELDING EFFECTIVENESS	TEMPEST	
CITY/STATE	COMPANY NAME / WEBSITE	PHONE #																					
ALABAMA																							
Huntsville	EMC Compliance www.emccompliance.com	(256) 650-5261			•									•						•			
Huntsville	National Technical Systems www.nts.com	(256) 837-4411		•	•		•	•	•	•	•			•	•	•	•		•	•	•		
ARIZONA																							
Chandler	DNB Engineering, Inc. www.dnbenginc.com	(480) 405-6160			•	•	•				•		•	•	•				•	•	•		
Mesa	Compliance Testing, LLC, aka Flom Test Lab www.compliancetesting.com	(480) 926-3100		•	•		•	•	•	•	•				•	•			•		•		
Mesa	Robinson's Engineering Consultants www.robinsonsenterprises.com	(480) 361-2539	Contact lab for testing capabilities.																				
Scottsdale	General Dynamics Missions Systems www.gdc4s.com	(480) 441-3033													•	•						•	•
Tempe	Lab-Tech, Inc. www.advancedtechnologieslab.com	(480) 317-0700					•																
Tempe	National Technical Systems www.nts.com	(480) 966-5517	•	•	•	•	•	•	•	•	•	•	•	•				•		•	•		
CALIFORNIA																							
Anaheim	EMC TEMPEST Engineering http://emctempest.com	(714) 778-1726			•		•					•		•				•		•	•		
Brea	CKC Laboratories, Inc. www.ckc.com	(714) 993-6112		•	•		•	•	•	•	•				•	•						•	
Brea	Compatible Electronics, Inc. www.celectronics.com	(714) 579-0500		•	•	•	•	•	•	•	•			•	•						•		
Carlsbad	NEMKO www.nemko.com	(760) 444-3500	•	•	•	•	•	•	•	•	•	•	•	•	•	•	•	•	•	•	•	•	
Costa Mesa	Independent Testing Laboratories, Inc. www.itltesting.net	(714) 662-1011			•		•				•			•						•			
Dana Point	NTS https://www.nts.com/locations/danapoint	(949) 429-8602		•	•	•	•	•	•	•	•	•	•	•				•		•			

USA continued

CITY/STATE	COMPANY NAME / WEBSITE	PHONE #	BELLCORE/TELCORDIA	CB/CAB/TCB/CB/CAB/TCB	EMISSIONS	EMP/LIGHTNING EFFECTS	ESD	EURO CERTIFICATIONS	FCC PART 15 & 18	FCC PART 68	IMMUNITY	LIGHTNING STRIKE	MIL-STD 188/125	MIL-STD 461	NVLAP/AZLA APPROVED	PRODUCT SAFETY	RADHAZ TESTING	RS103 > 200 V/METER	REPAIR/CALIBRATION	RTCA DO-160	SHIELDING EFFECTIVENESS	TEMPEST	
El Dorado Hills	Sanesi Associates	(916) 496-1760		•	•		•	•	•		•										•		
Fremont	CKC Laboratories, Inc. www.ckc.com	(510) 249-1170		•	•	•	•	•	•		•	•		•	•	•		•		•	•		
Fremont	Underwriters Laboratories, Inc. www.ul.com	(510) 319-4000	•	•	•		•	•	•	•	•				•	•							
Fremont	Elma Electronics, Inc. www.elma.com	(510) 656-3400			•			•													•		
Fremont	HCT America http://hctamerica.com	(510) 933-8848		•	•		•	•			•			•	•						•		
Fullerton	DNB Engineering, Inc. www.dnbenginc.com	(714) 870-7781			•	•	•					•	•	•	•			•			•	•	
Fullerton	National Technical Systems (NTS) www.nts.com	(714) 879-6110		•	•	•	•	•	•		•	•	•	•	•			•			•	•	
Irvine	7Layers, Inc. www.7layers.com	(949) 716-6512		•	•		•	•	•		•												
Irvine	Element EMC www.nwemc.com	(949) 861-8918		•	•		•	•			•				•								
Lake Forest	Compatible Electronics, Inc. www.celectronics.com	(949) 587-0400		•	•		•	•	•		•			•	•	•					•		
Lake Forest	Intertek (Lake Forest) www.intertek.com	(800) 967 5352		•	•	•	•	•	•		•				•	•							
Los Angeles	Field Management Services www.fms-corp.com	(323) 937-1562																				•	
Mariposa	CKC Laboratories, Inc. www.ckc.com	(209) 966-5240		•	•		•	•	•		•			•	•	•					•		
Menlo Park	Intertek (Menlo Park) www.intertek.com	(800) 967-5352	•	•	•	•	•	•	•		•			•	•	•							
Milpitas	CETECOM Inc. www.cetecom.com	(408) 586-6200		•	•		•	•	•		•				•	•							
Moffett Field	RMV Technology Group LLC - NASA Ames Research Center: www.esdrmv.com	(650) 964-4792					•								•						•		
Mountain View	Electro Magnetic Test, Inc. www.emtlabs.com	(650) 965-4000		•	•		•	•	•	•	•	•			•	•							
Newark	NTS https://www.nts.com/locations/silicon_valley	(877) 245-7800		•	•			•	•		•				•								
North Highlands	Northrop Grumman ESL www.northropgrumman.com	(916) 570-4340			•		•	•			•			•							•	•	•
Orange	G & M Compliance, Inc. www.gmcompliance.com	(714) 628-1020	•	•	•	•	•	•	•	•	•	•	•	•	•	•	•	•	•	•	•	•	•
Pleasanton	Intertek (Pleasanton) www.intertek.com	(800) 967-5352		•	•		•	•	•		•												
Pleasanton	MiCOM Labs www.micomlabs.com	(925) 462-0304			•		•	•	•		•			•									
Pleasanton	TÜV Rheinland of North America, Inc. www.tuv.com	(925) 249-9123		•	•		•	•	•		•			•	•	•							
Poway	APW Electronic Solutions www.2.eem.com	(858) 679-4550						•		•			•										
Rancho St. Margarita	Aegis Labs, Inc. http://aegislabsinc.com	(949) 751-8089	•	•			•	•		•				•	•								

USA continued

CITY/STATE	COMPANY NAME / WEBSITE	PHONE #	BELLCORE/TELCORDIA	CB/CAB/TCB CB/CAB/TCB	EMISSIONS	EMP/LIGHTNING EFFECTS	ESD	EURO CERTIFICATIONS	FCC PART 15 & 18	FCC PART 68	IMMUNITY	LIGHTNING STRIKE	MIL-STD 188/125	MIL-STD 461	NVLAP/AZLA APPROVED	PRODUCT SAFETY	RADHAZ TESTING	RS103 > 200 V/METER	REPAIR/CALIBRATION	RTCA DO-160	SHIELDING EFFECTIVENESS	TEMPEST
Redondo Beach	Northrop Grumman Space Tech. Sector www.northropgrumman.com	(310) 812-3162			•	•	•				•		•	•			•	•		•	•	•
Riverside	DNB Engineering, Inc. www.dnbenginc.com	(951) 637-2630	•		•		•	•	•	•	•					•						
Sacramento	Northrop-Grumman EM Systems Lab www.northropgrumman.com	(916) 570-4340			•		•		•	•				•						•	•	•
San Diego	Intertek (San Diego) www.intertek.com	(800) 967-5352		•	•		•	•	•		•											
San Diego	TDK-Lambda Electronics www.lambda.com	(619) 575-4400			•				•		•											
San Diego	TÜV SÜD America, Inc. www.tuvamerica.com	(858) 678-1400		•	•		•	•	•		•	•			•	•				•		
Santa Clara	Montrose Compliance Services, Inc. www.montrosecompliance.com	(408) 247-5715			•			•	•		•					•						
Santa Clara	MET Laboratories, Inc. www.metlabs.com	(408) 748-3585	•	•	•	•	•	•	•	•	•	•	•	•	•	•	•	•	•	•	•	•
Santa Clara	TÜV Rheinland EMC Test Center www.tuv.com	(408) 492-9395		•	•		•	•	•		•				•	•	•					
San Jose	Arc Technical Resources, Inc. www.arctechnical.com	(408) 263-6486					•	•	•	•	•	•	•					•		•	•	
San Jose	ATLAS Compliance & Engineering Inc. www.atlasce.com	(866) 573-9742			•		•	•	•		•	•			•	•				•		
San Jose	EMCE Engineering, Inc. www.universalconpliance.com	(510) 490-4307	•	•	•		•	•	•	•	•			•	•			•				
San Jose	Safety Engineering Laboratory www.seldirect.com	(408) 544-1890						•								•						
San Jose	Underwriters Laboratories, Inc. www.ul.com	(408) 754-6500	•		•		•	•	•	•	•				•	•					•	
San Marcos	RF Exposure Lab, LLC www.rfexposurelab.com	(760) 471-2100													•		•					
Sunnyvale	Bay Area Compliance Labs. www.baclcorp.com	(408) 732-9162	•	•	•	•	•	•	•	•	•				•	•						
Sunol	ITC Engineering Services, Inc. www.itcemc.com	(925) 862-2944			•		•	•	•	•	•			•	•	•		•				
Torrance	Lyncole XIT Grounding www.lyncol.com	(310) 214-4000	•									•										
Trabuco Canyon	RFI International www.rfiinternational.com	(949) 888-1607			•				•	•	•					•						
Union City	MET Laboratories, Inc. www.metlabs.com	(510) 489-6300	•	•	•		•	•	•	•	•	•		•	•	•	•	•	•	•	•	•
COLORADO																						
Boulder	Ball Aerospace & Technology Corp. www.ballaerospace.com	(303) 939-4618			•		•				•		•	•				•		•	•	
Boulder	Intertek (Boulder) www.intertek.com	(800) 967-5352		•	•	•	•	•	•	•	•			•	•	•			•			

USA continued

CITY/STATE	COMPANY NAME / WEBSITE	PHONE #	BELLCORE/TELCORDIA	CB/CAB/TCB CB/CAB/TCB	EMISSIONS	EMP/LIGHTNING EFFECTS	ESD	EURO CERTIFICATIONS	FCC PART 15 & 18	FCC PART 68	IMMUNITY	LIGHTNING STRIKE	MIL-STD 188/125	MIL-STD 461	NVLAP/A2LA APPROVED	PRODUCT SAFETY	RADHAZ TESTING	RS103 > 200 V/METER	REPAIR/CALIBRATION	RTCA DO-160	SHIELDING EFFECTIVENESS	TEMPEST
Denver	Element www.element.com	(720) 340-7810	Contact lab for testing capabilities.																			
Lakewood	Electro Magnetic Applications, Inc. www.ema3d.com/location/	(303) 980-0070			•	•	•					•							•			
Longmont	NTS www.nts.com/location/longmont-co-vista-view/	(303) 776-7249		•	•		•	•	•		•			•	•						•	•
CONNECTICUT																						
Newtown	TÜV Rheinland of North America, Inc. www.tuv.com	(203) 426-0888		•	•		•	•	•		•				•	•	•					
FLORIDA																						
Lake Mary	Test Equipment Connection www.testequipmentconnection.com	(800) 615-8378																				•
Newberry	Timco Engineering, Inc. www.timcoengr.com	(352) 472-5500		•	•		•	•	•	•	•				•	•						
Orlando	NTS www.nts.com/location/orlando-fl-emi/	(407) 313-4230		•	•		•	•	•		•			•	•				•		•	
Orlando	National Technical Systems NTS www.nts.com/location/orlando-fl-environmental/	(407) 293-5844		•	•	•	•	•	•		•			•	•				•		•	•
Tampa	TÜV SÜD America, Inc. www.tuv-sud-america.com/us-en	(813) 284-2715	•	•	•	•	•	•	•		•	•		•	•	•			•		•	•
GEORGIA																						
Alpharetta	EMC Testing Laboratories, Inc. www.emctestng.com	(770) 475-8819			•		•		•	•	•		•		•							•
Alpharetta	U.S. Technologies, Inc. www.ustechnologies.com	(770) 740-0717	•		•		•	•	•	•	•	•			•	•					•	•
Duluth	Intertek (Duluth) www.intertek.com	(800) 967-5352		•	•		•	•	•		•											
Peachtree	Panasonic Automotive: https://na.panasonic.com/us/automotive-solutions	(770) 487-3356			•		•				•				•							
Suwanee	SGS North America www.sgsgroup.us.com	(770) 570-1800			•		•	•	•		•				•	•					•	
ILLINOIS																						
Downers Grove	Elite Electronic Engineering, Inc. www.elitetest.com	(630) 495-9770	•	•	•	•	•	•	•	•	•	•	•	•	•	•	•	•	•	•	•	•
Mundelein	Midwest EMI Associates, Inc. www.midemi.com	(847) 393-7316			•		•	•	•		•			•	•						•	•
Northbrook	Underwriters Laboratories, LLC. www.ul.com	(847) 272-8800	•	•	•		•	•	•	•	•				•	•						•
Mount Prospect	National Technical Systems NTS www.nts.com	(847) 934-5300	•	•	•	•	•	•	•		•	•		•	•	•					•	•
Poplar Grove	LF Research EMC Design & Test Facility www.lfresearch.com	(815) 566-5655		•	•		•	•	•		•	•		•	•				•	•	•	•
Rockford	National Technical Systems NTS www.nts.com	(815) 315-9250		•	•		•	•	•		•											

USA continued

CITY/STATE	COMPANY NAME / WEBSITE	PHONE #	BELLCORE/TELCORDIA	CB/CAB/TCB CB/CAB/TCB	EMISSIONS	EMP/LIGHTNING EFFECTS	ESD	EURO CERTIFICATIONS	FCC PART 15 & 18	FCC PART 68	IMMUNITY	LIGHTNING STRIKE	MIL-STD 188/125	MIL-STD 461	NVLAP/AZLA APPROVED	PRODUCT SAFETY	RADHAZ TESTING	RS103 > 200 V/METER	REPAIR/CALIBRATION	RTCA DO-160	SHIELDING EFFECTIVENESS	TEMPEST
Romeoville	Radiometrics Midwest Corp. www.radiomet.com	(815) 293-0772	•		•	•	•	•	•		•	•		•	•			•		•	•	
Roselle	Electri-Flex Company www.electriflex.com	(800) 323-6174																				•
Wheeling	D.L.S. Electronic Systems, Inc. www.dlsemc.com	(847) 537-6400	•	•	•	•	•	•	•		•	•		•	•	•		•		•	•	
INDIANA																						
Indianapolis	Raytheon Technical Services Co., EMI Lab www.raytheon.com	(317) 306-4872			•						•			•	•							•
Indianapolis	F2 Labs, Inc. http://f2labs.com	(877) 405-1580			•	•	•	•	•	•	•	•			•	•				•		
KANSAS																						
Louisburg	Rogers Labs, Inc. www.rogerslabs.com	(913) 837-3214			•		•		•		•			•	•					•		
KENTUCKY																						
Lexington	Lexmark International EMC Lab www.lexmark.com	(859) 232-2000							•													
Lexington	Intertek (Lexington) www.intertek.com	(800) 976-5352	•	•	•	•	•	•	•		•			•	•							
MAINE																						
Portland	Enerdoor www.enerdoor.com	(207) 210-6511			•		•	•			•											
MARYLAND																						
Baltimore	MET Laboratories, Inc. www.metlabs.com	(410) 354-3300	•	•	•	•	•	•	•	•	•	•	•	•	•	•	•	•	•	•	•	•
Columbia	Advanced Programs Inc. www.advprograms.com	(410) 312-5800												•						•		•
Columbia	PCTest Engineering Lab www.pctestlab.com	(410) 290-6652			•	•	•	•	•	•	•				•		•					•
Damascus	F2 Labs, Inc. http://f2labs.com	(301) 253-4500			•	•	•	•	•	•	•	•			•	•				•		
Elkridge	ATEC Industries, Ltd. www.atecindustries.com	(443) 459-5080				•	•					•	•	•	•							•
Frederick	The American Association for Lab Accreditation; www.a2la.org	(301) 644-3248													•							
Frederick	Washington Labs www.wll.com	(301) 216-1500							•							•						
Gaithersburg	Washington Laboratories, Ltd. www.wll.com	(301) 216-1500			•	•		•	•	•	•	•	•	•	•	•	•	•	•	•	•	•
Rockville	P.J. Mondin, P.E. Consultants	(301) 460-5864							•					•							•	•
MASSACHUSETTS																						
Billerica	Quest Engineering Solutions www.qes.com	(978) 667-7000																				•

USA continued

CITY/STATE	COMPANY NAME / WEBSITE	PHONE #	BELLCORE/TELCORDIA	CB/CAB/TCB CB/CAB/TCB	EMISSIONS	EMP/LIGHTNING EFFECTS	ESD	EURO CERTIFICATIONS	FCC PART 15 & 18	FCC PART 68	IMMUNITY	LIGHTNING STRIKE	MIL-STD 188/125	MIL-STD 461	NVLAP/AZLA APPROVED	PRODUCT SAFETY	RADHAZ TESTING	RS103 > 200 V/METER	REPAIR/CALIBRATION	RTCA DO-160	SHIELDING EFFECTIVENESS	TEMPEST
Boxborough	Intertek (Boxborough) www.intertek.com	(800) 967-5352		•	•	•	•	•	•	•	•			•	•	•		•		•	•	
Boxborough	National Technical Systems www.nts.com	(978) 266-1001		•	•	•	•	•	•	•	•	•	•	•	•			•		•	•	
Burlington	NELCO www.nelcoworldwide.com	(781) 933-1940																			•	
Littleton	TÜV Rheinland of North America, Inc. www.tuv.com	(978) 266-9500		•	•		•	•	•		•					•						
Littleton	Compliance Management Group www.cmgcorp.net	(978) 431-1985	•		•		•	•	•		•				•	•					•	
Milford	Test Site Services, Inc. www.testsiteservices.com	(508) 634-3444	•	•	•		•	•	•	•	•	•		•	•	•		•		•	•	
Newton	EMC Test Design, LLC www.emctd.com	(508) 292-1833															•					
Peabody	TÜV SUD America Inc. www.tuv-sud-america.com/us-en	(978) 573-2500	•	•	•	•	•	•	•	•	•	•	•	•	•	•		•		•	•	
Pittsfield	National Technical Systems www.nts.com	(413) 499-2135		•	•	•	•	•	•		•	•			•					•		
Woburn	Chomerics, Div. of Parker Hannifin Corp. www.chomerics.com	(781) 935-4850			•	•	•	•	•		•	•	•	•	•	•	•	•		•	•	
MICHIGAN																						
Brighton	Willow Run Test Labs, LLC www.wrtest.com	(734) 252-9785			•		•	•													•	
Burton	Trialon Corporation www.trialon.com	(810) 742-8500			•		•				•				•							
Detroit	National Technical Systems www.nts.com	(313) 835-0044		•	•		•	•	•		•				•			•				
Detroit	TÜV Rheinland of North America, Inc. www.tuv.com/en/middleeast/home.jsp	(734) 207-9852		•	•		•	•	•		•				•							
Grand Rapids	Intertek (Grand Rapids) www.intertek.com	(800) 967-5352		•	•	•	•	•	•	•	•	•			•	•		•		•		
Holland	TÜV SÜD America, Inc. www.tuv-sud-america.com/us-en	(616) 546-3902		•	•		•	•	•		•								•			
Novi	Underwriters Laboratories, Inc. www.ul.com	(248) 427-5300			•		•	•			•			•	•	•				•	•	
Plymouth	Intertek (Plymouth) www.intertek.com	(800) 967-5352		•	•		•	•	•		•											
Plymouth	TÜV SÜD America, Inc. www.tuvamerica.com	(734) 455-4841	•	•	•	•	•	•	•	•	•	•	•	•	•	•		•			•	
Sister Lakes	AHD EMC Lab www.ahde.com	(269) 313-2433			•		•	•	•		•			•	•						•	
MINNESOTA																						
Brooklyn Park	Element www.element.com	(612) 638-5136		•	•		•	•	•		•				•							
Glencoe	International Certification Services, Inc. www.icsi-us.com	(320) 864-4444	•	•	•	•	•	•	•	•	•	•	•	•	•	•				•	•	

USA continued

CITY/STATE	COMPANY NAME / WEBSITE	PHONE #	BELLCORE/TELCORDIA	CB/CAB/TCB CB/CAB/TCB	EMISSIONS	EMP/LIGHTNING EFFECTS	ESD	EURO CERTIFICATIONS	FCC PART 15 & 18	FCC PART 68	IMMUNITY	LIGHTNING STRIKE	MIL-STD 188/125	MIL-STD 461	NVLAP/AZLA APPROVED	PRODUCT SAFETY	RADHAZ TESTING	RS103 > 200 V/METER	REPAIR/CALIBRATION	RTCA DO-160	SHIELDING EFFECTIVENESS	TEMPEST
Minneapolis	Element www.element.com	(952) 888-7795													•							
MISSOURI																						
St. Louis	Boeing-St. Louis EMC Lab www.boeing.com	(314) 232-0232												•	•			•				•
NEBRASKA																						
Lincoln	NCEE Labs www.nceelabs.com	(402) 323-6233			•		•	•	•		•			•	•	•					•	
NEW HAMPSHIRE																						
Goffstown	Retlif Testing Laboratories www.retlif.com	(603) 497-4600		•	•	•	•	•	•	•	•	•		•	•	•	•	•			•	•
Hudson	Core Compliance Testing Services www.corecompliancetesting.com	(603) 889-5545			•		•		•		•	•			•							
Sandown	Compliance Worldwide, Inc. www.cw-inc.com	(603) 887-3903			•		•		•	•	•	•			•							
NEW JERSEY																						
Annandale	NU Laboratories, Inc. www.nulabs.com	(908) 713-9300					•							•	•							•
Bridgewater	Lichtig EMC Consulting www.lichtigemc.com	(908) 541-0213	•																			
Camden	L-3 Communication Systems-East www.l3harris.com/	(856) 338-3000	Contact lab for testing capabilities.																			
Clifton	NJ-MET www.njmetmtl.com	(973) 546-5393	•							•												•
Edison	Metex Corporation www.metexcorp.com	(732) 287-0800																				•
Edison	TESEQ, Inc. www.teseq.com	(732) 417-0501				•				•												
Fairfield	Intertek (Fairfield) www.intertek.com	(800) 967-5352		•	•		•	•	•		•											
Fairfield	SGS U.S. Testing Co., Inc. www.sgsgroup.us.com	(973) 575-5252	•		•			•							•	•						
Farmingdale	EMC Technologists A Div. of I2R Corp. www.emctech.com	(732) 919-1100	•		•		•	•	•	•	•			•								
Hillsborough	Advanced Compliance Laboratory, Inc. http://ac-lab.com	(908) 927-9288 ext. 106			•			•	•	•	•				•	•						
Rutherford	SGS International Certification Services, Inc.; www.sgsgroup.us.com	(201) 508-3000						•														
Thorofare	NDI Engineering Company www.ndieng.com	(856) 848-0033																				•
Tinton Falls	National Technical Systems (NTS) www.nts.com	(732) 936-0800	•	•	•	•	•	•	•	•	•	•	•	•	•	•	•	•	•	•	•	•
NEW MEXICO																						
Albuquerque	Advanced Testing Services, Inc. www.advanced-testing.com	(505) 292-2032											•				•					•

USA continued

CITY/STATE	COMPANY NAME / WEBSITE	PHONE #	BELLCORE/TELECORDIA	CB/CAB/TCB CB/CAB/TCB	EMISSIONS	EMP/LIGHTNING EFFECTS	ESD	EURO CERTIFICATIONS	FCC PART 15 & 18	FCC PART 68	IMMUNITY	LIGHTNING STRIKE	MIL-STD 188/125	MIL-STD 461	NVLAP/AZLA APPROVED	PRODUCT SAFETY	RADHAZ TESTING	RS103 > 200 V/METER	REPAIR/CALIBRATION	RTCA DO-160	SHIELDING EFFECTIVENESS	TEMPEST
White Sands	USA WSMR, Survivability Directorate www.wsmr.army.mil	(575) 678-1621			•	•	•				•	•		•			•	•			•	
NEW YORK																						
College Point	Aero Nav Laboratories, Inc. www.aeronavlabs.com	(718) 939-4422	•			•			•		•	•		•	•			•		•	•	•
Deer Park	Universal Shielding Corp. www.universalshielding.com	(631) 392-4888																			•	
Endicott	BAE Systems Controls, Inc. www.baesystems.com	(607) 770-2000			•	•						•		•	•			•		•		
Liverpool	Source1 Solutions www.source1compliance.com	(315) 730-5667			•		•	•	•		•			•		•					•	
Medford	American Environments Co. www.aeco.com	(631) 736-5883	•		•	•	•	•	•		•	•				•				•	•	
Melville	Underwriters Laboratories, LLC. www.ul.com	(631) 271-6200	•	•	•		•	•	•	•	•				•	•					•	
Palmyra	Source1 Solutions www.source1compliance.com	(315) 730-5667			•			•			•			•		•					•	
Poughkeepsie	IBM Corp. Poughkeepsie EMC Lab www.ibm.com	(845) 433-1234		•					•													
Webster	TÜV Rheinland Of North America www.tuv.com	(585) 645-0125		•	•		•	•	•		•				•	•	•					
Ronkonkoma	Retlif Testing Laboratories www.retlif.com	(631) 737-1500		•	•	•	•	•	•	•	•	•		•	•	•	•	•		•	•	
NORTH CAROLINA																						
Cary	CertifiGroup www.certifigroup.com	(919) 466-9283		•				•							•	•						
Cary	MET Laboratories, Inc. www.metlabs.com	(919) 481-9319	•	•	•		•	•	•	•	•	•		•	•	•		•		•	•	
Greensboro	Schneider Electric Industrial Repair Services www.schneiderelectricrepair.com	(800) 950-9550																		•		
Greenville	Lawrence Behr Associates (LBA) www.lbagroup.com	(252) 757-0279															•				•	
Res. Triangle Pk.	Educated Design & Dev., Inc. (ED&D) www.productsafet.com	(919) 469-9434		•											•	•			•			•
Res. Triangle Pk.	IBM RTP EMC Test Labs www.ibm.com	(800) 426-4968			•				•		•											
Res. Triangle Pk.	Underwriters Laboratories, LLC. www.ul.com	(919) 549-1400	•	•	•		•	•	•	•	•				•	•					•	
OHIO																						
Cleveland	CSA International www.csa-international.org	(216) 524-4990						•								•						
Cleveland	NASA GRC EMI Lab www1.grc.nasa.gov	(216) 433-4000												•							•	
Colombus	Intertek (Colombus) www.intertek.com	(800) 967 5352		•	•		•	•	•		•											
Mason	L-3 Cincinnati Electronics www.cinele.com	(513) 573-6100			•		•				•			•				•		•		
Mentor	EU Compliance Services, Inc. www.eucs.com	(440) 918-1425			•		•	•			•					•					•	

USA continued

CITY/STATE	COMPANY NAME / WEBSITE	PHONE #	BELLCORE/TELORDIA	CB/CAB/TCB CB/CAB/TCB	EMISSIONS	EMP/LIGHTNING EFFECTS	ESD	EURO CERTIFICATIONS	FCC PART 15 & 18	FCC PART 68	IMMUNITY	LIGHTNING STRIKE	MIL-STD 188/125	MIL-STD 461	NVLAP/A2LA APPROVED	PRODUCT SAFETY	RADHAZ TESTING	RS103 > 200 V/METER	REPAIR/CALIBRATION	RTCA DO-160	SHIELDING EFFECTIVENESS	TEMPEST
Middlefield	F2 Labs, Inc. http://f2labs.com	(440) 632-5541		•	•	•	•	•	•	•	•	•			•	•					•	
Springboro	Pioneer Automotive Technologies	(937) 746-6600			•		•		•		•			•	•							
OREGON																						
Beaverton	Tektronix www.tek.com	(503) 627-4133	•												•					•		
Fairview	Intertek (Fairview) www.intertek.com	(800) 967-5352		•	•			•	•		•											
Hillsboro	Element www.element.com	(503) 648-1818	•												•					•		
Hillsboro	ElectroMagnetic Investigations, LLC https://emicomply.com/contact/	(503) 466-1160			•			•	•		•			•	•						•	
Hillsboro	Element www.element.com	(503) 844-4066		•	•			•	•		•				•					•	•	
Portland	TÜV SÜD America, Inc. www.tuv-sud-america.com/us-en	(503) 598-7580		•	•	•	•	•	•		•					•						
PENNSYLVANIA																						
Chambersburg	Cuming Lehman Chambers http://cuminglehman.com	(717) 263-4101			•						•			•						•		
Glenside	Electro-Tech Systems, Inc. www.electrotechsystems.com	(215) 887-2196	•				•														•	
Harleysville	Retlif Testing Laboratories www.retlif.com	(215) 256-4133		•	•	•	•	•	•	•	•	•	•	•	•	•	•	•	•	•	•	•
Hatfield	Laboratory Testing Inc. www.labtesting.com	(800) 219-9095													•				•			
New Castle	Keystone Compliance LLC www.keystonecompliance.com	(724) 657-9940	•	•	•	•	•	•	•	•	•	•	•	•	•	•	•	•	•	•	•	•
Pottstown	BEC Inc. www.bec-ccl.com	(610) 970-6880			•		•		•		•				•						•	
State College	Videon Central, Inc. www.videon-central.com	(814) 235-1111			•		•	•	•											•		
West Conshohocken	R&B Laboratory www.rblaboratory.com	(610) 825-1960			•	•	•				•	•					•	•		•	•	
TENNESSEE																						
Knoxville	Global Testing Labs LLC www.globaltestinglabs.com	(865) 523-9972			•				•		•				•							
Knoxville	AMS Corporation www.ams-corp.com	(865) 691-1756			•		•				•				•							
TEXAS																						
Austin	BAE Systems IDS Test Services www.baesystems.com	(512) 926-2800											•							•		
Austin	MET Laboratories, Inc. www.metlabs.com	(512) 287-2500	•	•	•	•	•	•	•	•	•	•	•	•	•	•	•	•	•	•	•	•
Bartonville	Nemko USA www.nemko.com	(940) 294-7057		•	•		•	•	•	•	•			•	•	•	•	•	•	•	•	•
Cedar Park	TDK RF Solutions, Inc. www.tdkrfsolutions.com	(512) 258-9478			•		•	•	•	•	•				•							
Elmendorf	Intertek (Elmendorf) www.intertek.com	(800) 967-5352		•	•		•	•	•		•											

USA continued

CITY/STATE	COMPANY NAME / WEBSITE	PHONE #	BELLCORE/TELCORDIA	CB/CAB/TCB CB/CAB/TCB	EMISSIONS	EMP/LIGHTNING EFFECTS	ESD	EURO CERTIFICATIONS	FCC PART 15 & 18	FCC PART 68	IMMUNITY	LIGHTNING STRIKE	MIL-STD 188/125	MIL-STD 461	NVLAP/AZLA APPROVED	PRODUCT SAFETY	RADHAZ TESTING	RS103 > 200 V/METER	REPAIR/CALIBRATION	RTCA DO-160	SHIELDING EFFECTIVENESS	TEMPEST
Plano	National Technical Systems www.nts.com	(972) 509-2566	•	•	•	•	•	•	•	•	•	•	•	•	•			•	•	•		
Plano	Element www.element.com	(469) 304-5255		•	•		•		•		•				•							
Plano	Intertek (Plano) www.intertek.com	(800) 967-5352		•	•	•	•	•	•		•				•	•						
Round Rock	Professional Testing (EMI), Inc. www.ptitest.com	(512) 244-3371			•		•		•		•	•		•	•				•	•	•	
San Antonio	Southwest Research Institute www.swri.org	(210) 684-5111	•	•	•	•	•	•	•	•	•	•	•	•	•	•		•	•	•	•	
UTAH																						
Coalville	DNB Engineering, Inc. www.dnbenginc.com	(435) 336-4433	•		•		•	•	•	•	•					•						
Draper	VPI Technology www.vpитеchnology.com	(801) 495-2310			•		•	•	•	•				•	•	•						
Ogden	Little Mountain Test Facility (LMTF)	(801) 315-2320			•	•	•				•		•	•				•		•	•	
Salt Lake City	L3 Communication Systems-West www.l3harris.com	(801) 594-2000			•			•	•					•						•		
VERMONT																						
Middlebury	Green Mountain Electromagnetics, Inc. www.gmelectro.com	(802) 388-3390						•	•	•			•	•								
VIRGINIA																						
Fredericksburg	E-LABS INC. www.e-labsinc.com	(540) 834-0372			•		•				•			•	•		•			•	•	
Fredericksburg	Vititech Engineering, LLC http://vititech.net	(540) 286-1984	•	•					•	•	•		•	•								•
Herndon	Rhein Tech Laboratories, Inc. www.rheintech.com	(703) 689-0368			•		•	•	•	•				•	•	•				•	•	
Reston	TEMPEST, Inc. (VA) www.tempest-inc.com	(703) 836-7378			•		•	•	•	•			•	•								•
Richmond	Technology International, Inc. www.techintl.com	(804) 794-4144		•	•		•	•			•				•							•
WASHINGTON																						
Bothell	CKC Laboratories, Inc www.ckc.com	(425) 402-1717		•	•	•	•	•	•	•	•	•	•	•	•			•		•	•	
Bothell	Element www.element.com	(425) 984-6600			•		•		•		•				•	•						
WISCONSIN																						
Genoa City	D.L.S. Electronic Systems, Inc. www.dlsemc.com	(262) 279-0210		•	•				•						•							
Middleton	Intertek www.intertek.com	(800) 967-5352		•	•		•	•	•		•											
Neenah	International Compliance Laboratories www.icl-us.com	(920) 720-5555			•		•		•		•				•							

EMC/EMI CONSULTANTS DIRECTORY

WYATT TECHNICAL SERVICES LLC

Consultancy Services: EMC Consultation, EMC Design Reviews, Pre-Compliance Testing, Training Services
Kenneth Wyatt, principal consultant
56 Aspen Dr
Woodland Park, CO 80863
Phone: (719) 310-5418
www.emc-seminars.com

MICHAEL VIOLETTE, P.E., CEO

Consultancy Services: Radio Testing, Global Regulatory Standards
Michael Violette
Phone: (240) 401-1388
Email: mikev@wll.com
www.wll.com

GHERY S. PETTIT/PRESIDENT, PETTIT EMC CONSULTING LLC

Consultancy Services: EMC standards, product and laboratory design, and troubleshooting specializing in ITE related EMC.
Ghery S. Pettit
Phone: (360) 790-9672
Email: Ghery@PettitEMCConsulting.com
www.PettitEMCConsulting.com

PATRICK G. ANDRÉ/CONSULTANT, ANDRÉ CONSULTING, INC.

Consultancy Services: Troubleshooting, Design, Training and Test Support
Patrick G. André
Phone: (206) 406-8371
Email: pat@andreconsulting.com
<https://andreconsulting.com>

DAVID A. WESTON/EMC ENGINEER

Consultancy Services: EMC analysis, circuit and equipment design for EMC, EMI problem solving, R&D
David Weston
Phone: (613) 269-4247
Email: emccons0@gmail.com
www.emcconsultinginc.com

STEVEN FERGUSON/OWNER, COMPLIANCE DIRECTION, LLC

Consultancy Services: EMC/Electrical Safety/ Environmental Design, Test and Training, Risk Assessment, Control Procedures, Test Procedures
Steven Ferguson
Phone: (240) 401-7177
Email: stevef@comliancedirection.com
www.comliancedirection.com

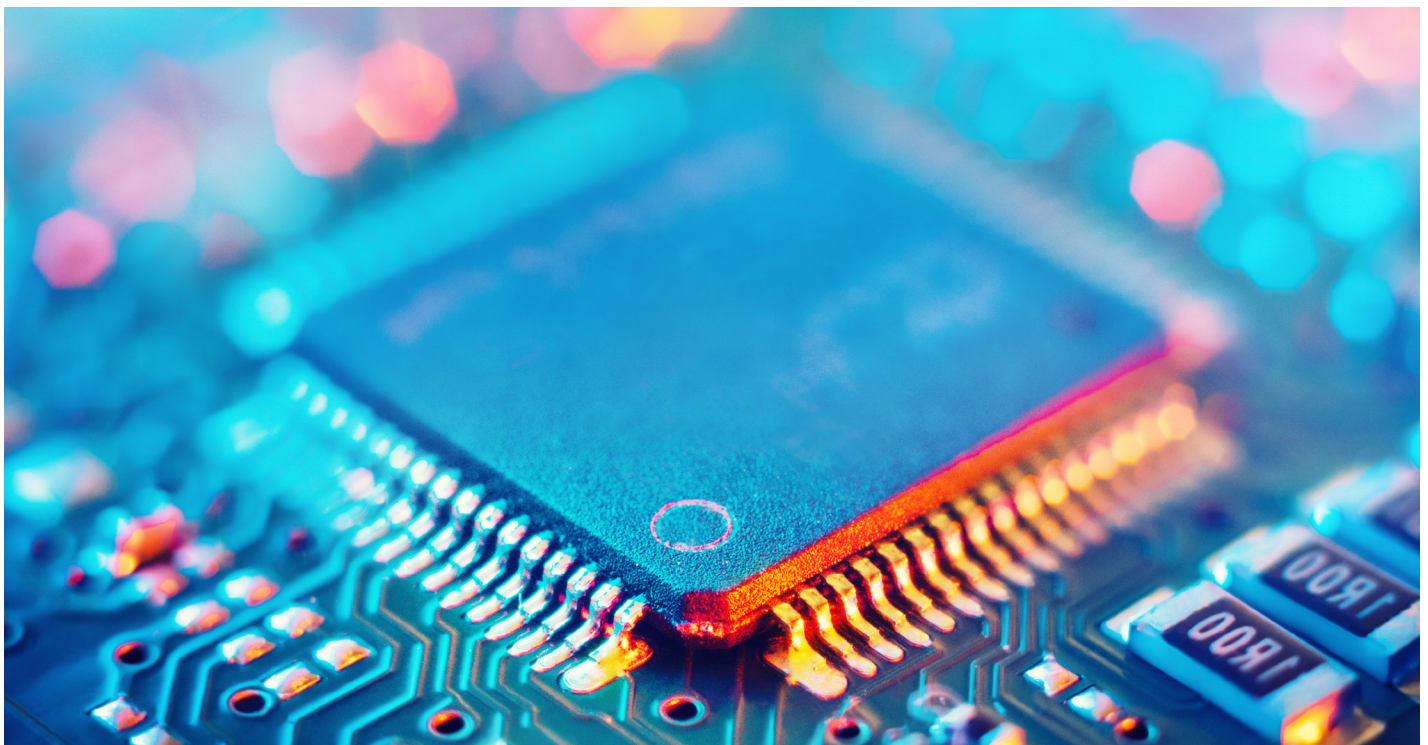

THE LEADER IN EMI GASKETS

Excellence by Design: Exceptional, Durable Shielding



When EMI protection is important, top manufacturers choose Spira EMI gaskets. Spira gaskets are well known for solving EMI shielding problems that no other gasket can solve, and are perfect for both military and commercial applications. Gaskets are designed to be highly reliable, and built to last the life of the system. Salt fog, high humidity and RoHS versions are available. Choose Spira gaskets to pass your shielding tests the first time.

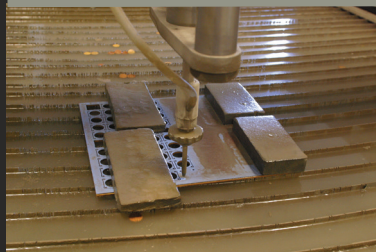

EMI & Environmental Connector-Seal Gaskets. Superior EMI and environmental protection for flange-mounted connectors in front or back mount configurations.

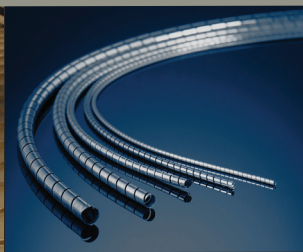

Spira-Shield. All Spira gaskets utilize our unique patented spiral design which yields EMI shielding quality up to 165 dB with exceptionally long life.

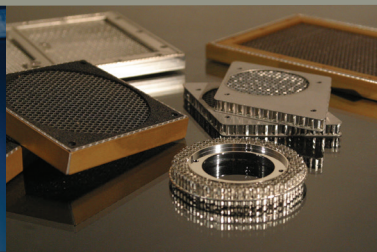

Shielded Honeycomb Air-Vent and Fan Filters. High and reliable shielded filters at competitive prices providing over 80dB of shielding at 1GHz.

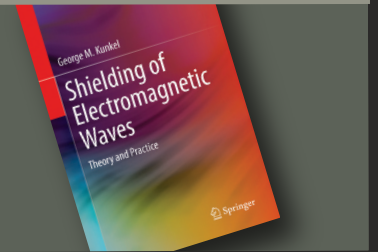

Groundbreaking new book on EMI Shielding Theory. A new, more accurate and efficient way for engineers to understand electromagnetic shielding theory and practice.

LEARN MORE & ORDER FREE SAMPLES - CONTACT US TODAY!

www.spira-emi.com • (818) 764-8222 • info@spira-emi.com

COMMON COMMERCIAL EMC STANDARDS

COMMERCIAL STANDARDS

The following are some of the most common commercial EMC standards. Most standards have a fee associated and most on the list are linked back to the source where they're available. If you're purchasing the printed version of this guide, then refer to the Standards Organizations in the References section for standards purchase information. Note that many Euro Norm (EN) versions of IEC standards may be purchased at a considerable discount from the Estonian Centre for Standardization, <https://www.evs.ee>.

FCC

<https://www.ecfr.gov>

Electronic Code of Federal Regulations (e-CFR)

CFR 47 - Part 15 (Radio Frequency Devices)

ANSI

<http://webstore.ansi.org>

Document Number	Title
C63.4	Methods of Measurement of Radio-Noise Emissions from Low-Voltage Electrical and Electronic Equipment in the Range of 9 kHz to 40 GHz

IEC

<https://webstore.iec.ch>

Document Number	Title
IEC 60601-1-2	Medical electrical equipment—Part 1-2: General requirements for basic safety and essential performance - Collateral Standard: Electromagnetic disturbances - Requirements and tests
IEC 60601-2-2	Medical electrical equipment—Part 2-2: Particular requirements for the basic safety and essential performance of high frequency surgical equipment and high frequency surgical accessories
IEC 60601-4-2	Medical electrical equipment—Part 4-2: Guidance and interpretation - Electromagnetic immunity: performance of medical electrical equipment and medical electrical systems
IEC 61000-3-2	Electromagnetic compatibility (EMC)—Part 3-2: Limits - Limits for harmonic current emissions (equipment input current ≤ 16 A per phase)
IEC 61000-3-3	Electromagnetic compatibility (EMC)—Part 3-3: Limits – Limitation of voltage changes, voltage fluctuations and flicker in public low-voltage supply systems, for equipment with rated current ≤ 16 A per phase and not subject to conditional connection
IEC 61000-4-2	Electromagnetic compatibility (EMC)—Part 4-2: Testing and measurement techniques - Electrostatic discharge immunity test
IEC 61000-4-3	Electromagnetic compatibility (EMC)—Part 4-3: Testing and measurement techniques - Radiated, radio-frequency, electromagnetic field immunity test
IEC 61000-4-4	Electromagnetic compatibility (EMC)—Part 4-4: Testing and measurement techniques – Electrical fast transient/burst immunity test

IEC 61000-4-5	Electromagnetic compatibility (EMC) - Part 4-5: Testing and measurement techniques - Surge immunity test
IEC 61000-4-6	Electromagnetic compatibility (EMC) - Part 4-6: Testing and measurement techniques - Immunity to conducted disturbances, induced by radio-frequency fields
IEC 61000-4-7	Electromagnetic compatibility (EMC) - Part 4-7: Testing and measurement techniques - General guide on harmonics and interharmonics measurements and instrumentation, for power supply systems and equipment connected thereto
IEC 61000-4-8	Electromagnetic compatibility (EMC) - Part 4-8: Testing and measurement techniques - Power frequency magnetic field immunity test
IEC 61000-4-9	Electromagnetic compatibility (EMC) - Part 4-9: Testing and measurement techniques - Impulse magnetic field immunity test
IEC 61000-4-10	Electromagnetic compatibility (EMC) - Part 4-10: Testing and measurement techniques - Damped oscillatory magnetic field immunity test
IEC 61000-4-11	Electromagnetic compatibility (EMC) - Part 4-11: Testing and measurement techniques - Voltage dips, short interruptions and voltage variations immunity tests
IEC 61000-4-12	Electromagnetic compatibility (EMC) - Part 4-12: Testing and measurement techniques - Ring wave immunity test
IEC 61000-6-1	Electromagnetic compatibility (EMC) - Part 6-1: Generic standards - Immunity standard for residential, commercial and light-industrial environments
IEC 61000-6-2	Electromagnetic compatibility (EMC) - Part 6-2: Generic standards - Immunity standard for industrial environments
IEC 61000-6-3	Electromagnetic compatibility (EMC) - Part 6-3: Generic standards - Emission standard for residential, commercial and light-industrial environments
IEC 61000-6-4	Electromagnetic compatibility (EMC) - Part 6-4: Generic standards - Emission standard for industrial environments
IEC 61000-6-5	Electromagnetic compatibility (EMC) - Part 6-5: Generic standards - Immunity for power station and substation environments
IEC 61000-6-7	Electromagnetic compatibility (EMC) - Part 6-7: Generic standards - Immunity requirements for equipment intended to perform functions in a safety-related system (functional safety) in industrial locations
IEC 61326-1	Electrical equipment for measurement, control and laboratory use – EMC requirements – Part 1: General requirements
IEC 61326-2-1	Electrical equipment for measurement, control and laboratory use - EMC requirements - Part 2-1: Particular requirements - Test configurations, operational conditions and performance criteria for sensitive test and measurement equipment for EMC unprotected applications
IEC 61326-2-2	Electrical equipment for measurement, control and laboratory use - EMC requirements - Part 2-2: Particular requirements - Test configurations, operational conditions and performance criteria for portable test, measuring and monitoring equipment used in low-voltage distribution systems
IEC 61326-2-3	Electrical equipment for measurement, control and laboratory use - EMC requirements - Part 2-3: Particular requirements - Test configuration, operational conditions and performance criteria for transducers with integrated or remote signal conditioning
IEC 61326-2-4	Electrical equipment for measurement, control and laboratory use - EMC requirements - Part 2-4: Particular requirements - Test configurations, operational conditions and performance criteria for insulation monitoring devices according to IEC 61557-8 and for equipment for insulation fault location according to IEC 61557-9
IEC 61326-2-5	Electrical equipment for measurement, control and laboratory use - EMC requirements - Part 2-5: Particular requirements - Test configurations, operational conditions and performance criteria for field devices with field bus interfaces according to IEC 61784-1

IEC 61326-2-6	Electrical equipment for measurement, control and laboratory use - EMC requirements - Part 2-6: Particular requirements - In vitro diagnostic (IVD) medical equipment
IEC 61326-3-1	Electrical equipment for measurement, control and laboratory use - EMC requirements - Part 3-1: Immunity requirements for safety-related systems and for equipment intended to perform safety-related functions (functional safety) - General industrial applications
IEC 61326-3-2	Electrical equipment for measurement, control and laboratory use - EMC requirements - Part 3-2: Immunity requirements for safety-related systems and for equipment intended to perform safety-related functions (functional safety) - Industrial applications with specified electromagnetic environment
IEC 61340-3-1	Electrostatics - Part 3-1: Methods for simulation of electrostatic effects - Human body model (HBM) electrostatic discharge test waveforms

CISPR

<https://webstore.iec.ch>

Document Number	Title
CISPR 11	Industrial, scientific and medical (ISM) radio-frequency equipment - Electromagnetic disturbance characteristics - Limits and methods of measurement
CISPR 12	Vehicles, boats and internal combustion engines - Radio disturbance characteristics - Limits and methods of measurement for the protection of off-board receivers
CISPR 13	Sound and television broadcast receivers and associated equipment - Radio disturbance characteristics - Limits and methods of measurement
CISPR 14-1	Electromagnetic compatibility - Requirements for household appliances, electric tools and similar apparatus - Part 1: Emission
CISPR 14-2	Electromagnetic compatibility – Requirements for household appliances, electric tools and similar apparatus – Part 2: Immunity – Product family standard
CISPR 15	Limits and methods of measurement of radio disturbance characteristics of electrical lighting and similar equipment
CISPR 16-1-1	Specification for radio disturbance and immunity measuring apparatus and methods - Part 1-1: Radio disturbance and immunity measuring apparatus - Measuring apparatus
CISPR 16-1-2	Specification for radio disturbance and immunity measuring apparatus and methods - Part 1-2: Radio disturbance and immunity measuring apparatus - Coupling devices for conducted disturbance measurements
CISPR 16-1-3	Specification for radio disturbance and immunity measuring apparatus and methods - Part 1-3: Radio disturbance and immunity measuring apparatus - Ancillary equipment - Disturbance power
CISPR 16-1-4	Specification for radio disturbance and immunity measuring apparatus and methods - Part 1-4: Radio disturbance and immunity measuring apparatus - Antennas and test sites for radiated disturbance measurements
CISPR 16-1-5	Specification for radio disturbance and immunity measuring apparatus and methods - Part 1-5: Radio disturbance and immunity measuring apparatus - Antenna calibration sites and reference test sites for 5 MHz to 18 GHz
CISPR 16-1-6	Specification for radio disturbance and immunity measuring apparatus and methods - Part 1-6: Radio disturbance and immunity measuring apparatus - EMC antenna calibration
CISPR 16-2-1	Specification for radio disturbance and immunity measuring apparatus and methods - Part 2-1: Methods of measurement of disturbances and immunity - Conducted disturbance measurements

CISPR 16-2-2	Specification for radio disturbance and immunity measuring apparatus and methods - Part 2-2: Methods of measurement of disturbances and immunity - Measurement of disturbance power
CISPR 16-2-3	Specification for radio disturbance and immunity measuring apparatus and methods - Part 2-3: Methods of measurement of disturbances and immunity - Radiated disturbance measurements
CISPR 16-2-4	Specification for radio disturbance and immunity measuring apparatus and methods - Part 2-4: Methods of measurement of disturbances and immunity - Immunity measurements
CISPR TR 16-2-5	Specification for radio disturbance and immunity measuring apparatus and methods - Part 2-5: In situ measurements for disturbing emissions produced by physically large equipment
CISPR TR 16-3	Specification for radio disturbance and immunity measuring apparatus and methods - Part 3: CISPR technical reports
CISPR TR 16-4-1	Specification for radio disturbance and immunity measuring apparatus and methods - Part 4-1: Uncertainties, statistics and limit modeling - Uncertainties in standardized EMC tests
CISPR 16-4-2	Specification for radio disturbance and immunity measuring apparatus and methods - Part 4-2: Uncertainties, statistics and limit modeling - Measurement instrumentation uncertainty
CISPR TR 16-4-3	Specification for radio disturbance and immunity measuring apparatus and methods - Part 4-3: Uncertainties, statistics and limit modeling - Statistical considerations in the determination of EMC compliance of mass-produced products
CISPR TR 16-4-4	Specification for radio disturbance and immunity measuring apparatus and methods - Part 4-4: Uncertainties, statistics and limit modeling - Statistics of complaints and a model for the calculation of limits for the protection of radio services
CISPR TR 16-4-5	Specification for radio disturbance and immunity measuring apparatus and methods - Part 4-5: Uncertainties, statistics and limit modeling - Conditions for the use of alternative test methods
CISPR 17	Methods of measurement of the suppression characteristics of passive EMC filtering devices
CISPR TR 18-1	Radio interference characteristics of overhead power lines and high-voltage equipment - Part 1: Description of phenomena
CISPR TR 18-2	Radio interference characteristics of overhead power lines and high-voltage equipment - Part 2: Methods of measurement and procedure for determining limits
CISPR TR 18-3	Radio interference characteristics of overhead power lines and high-voltage equipment - Part 3: Code of practice for minimizing the generation of radio noise
CISPR 20	Sound and television broadcast receivers and associated equipment - Immunity characteristics - Limits and methods of measurement (to be withdrawn July 2020)
CISPR 24	Information technology equipment - Immunity characteristics - Limits and methods of measurement (to be withdrawn July 2020)
CISPR 25	Vehicles, boats and internal combustion engines - Radio disturbance characteristics - Limits and methods of measurement for the protection of on-board receivers
CISPR 32	Electromagnetic compatibility of multimedia equipment – Emission requirements
CISPR 35	Electromagnetic compatibility of multimedia equipment - Immunity requirements

MEDICAL EMC STANDARDS

COLLATERAL STANDARDS

<https://www.webstore.iec.ch>

Document Number	Title
IEC 60601-1-1	Safety requirements for medical electrical systems
IEC 60601-1-2	Electromagnetic disturbances - requirements and tests
IEC 60601-1-3	Radiation protection in diagnostic x-ray equipment
IEC 60601-1-6	General requirements for basic safety and essential performance - Usability
IEC 60601-1-8	General requirements for basic safety and essential performance - Alarm systems
IEC 60601-1-9	Requirements for environmentally conscious design
IEC 60601-1-10	Requirements for the development of physiologic closed-loop controllers
IEC 60601-1-11	Medical electrical equipment and medical electrical systems used in the home healthcare environment
IEC 60601-1-12	Medical electrical equipment and medical electrical systems used in the medical services environment

OTHER RELEVANT STANDARDS

<https://www.webstore.iec.ch>

Document Number	Title
CISPR 11	Emission requirements for ISM equipment
IEC 60601-1	General requirements for basic safety and essential performance
IEC TR 60601-4-2	Electromagnetic immunity performance
IEC TR 60601-4-3	Considerations of unaddressed safety aspects in the third edition of IEC 60601-1
IEC TR 62354	General testing procedures for medical electrical equipment
ISO 14708-1	Active implantable medical devices

For more extensive listings of medical standards, download the 2020 Medical EMC Guide:

<https://learn.interferencetechnology.com/2020-medical-emc-guide/>

EMC STANDARDS ORGANIZATIONS

American National Standards Institute
www.ansi.org

ANSI Accredited C63
www.c63.org

Asia Pacific Laboratory Accreditation Cooperation (APLAC)
<https://www.apac-accreditation.org/>

BSMI (Taiwan)
<http://www.bsmi.gov.tw/wSite/mp?mp=95>

Canadian Standards Association (CSA)
www.csa.ca

CISPR
http://www.iec.ch/dyn/www/f?p=103:7:0:::FSP_ORG_ID,FSP_LANG_ID:1298,25

CNCA (China)
<http://www.cnca.gov.cn/>

Electromagnetic Compatibility Industry Association UK
<http://www.emcia.org>

FDA Center for Devices & Radiological Health (CDRH)
<https://www.fda.gov/MedicalDevices/default.htm>

Federal Communications Commission (FCC)
www.fcc.gov

Gosstandart (Russia)
<https://gosstandart.gov.by/en/>

IEC
<http://www.iec.ch/index.htm>

IEEE Standards Association
<https://standards.ieee.org/>

IEEE EMC Society Standards Development Committee (SDCOM)
<https://standards.ieee.org/develop/index.html>

Industry Canada (Certifications and Standards)
http://www.ic.gc.ca/eic/site/smt-gst.nsf/eng/h_sf06165.html

ISO (International Organization for Standards)
<http://www.iso.org/iso/home.html>

RTCA
<https://www.rtca.org>

SAE EMC Standards Committee
www.sae.org

SAE EMC Standards
<http://www.sae.org/servlets/works/committeeHome.do?comID=TEVEES17>

VCCI (Japan, Voluntary Control Council for Interference)
http://www.vcci.jp/vcci_e/



REFERENCES & TOOLS

COMMON EMC-RELATED EQUATIONS

OHMS LAW

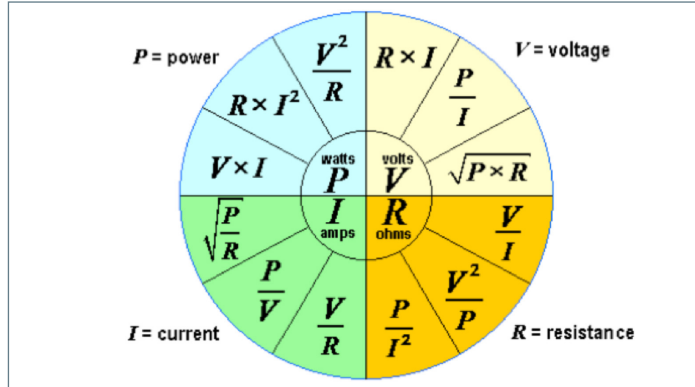

Ohms Law “formula wheel” for calculating resistance (R), voltage (V), current (I) or power (P), given at least two of the other values.

BANDWIDTH VERSUS RISE TIME

$$BW (GHz) = \frac{0.35}{RT (nsec)}$$

Empirically derived and applies for a square wave, with rise time measured at 10 and 90%. Example, for a rise time of 1 nsec, the bandwidth is 350 MHz.

BANDWIDTH VERSUS CLOCK FREQUENCY

$$BW_{clock}(GHz) = 5 \times F_{clock}(GHz)$$

Assuming the rise time of a clock is 7% of the period, we can approximate the bandwidth as shown.

Example, for a clock frequency of 100 MHz, the bandwidth is 500 MHz. That is, the highest significant sine-wave frequency component in a clock wave is the fifth harmonic.

PERIOD VERSUS FREQUENCY

$$F_{clock}(GHz) = \frac{1}{T_{clock}(nsec)}$$

PARTIAL SELF-INDUCTANCE OF A ROUND WIRE (1MM)

25 nH/inch or 1 nH/mm

Example, a 1.5 mm long via has a partial self-inductance of about 1.5 nH.

IMPEDANCE OF A WIRE

$$Z_{wire} (Ohms) = 2\pi f (GHz)L(nH)$$

Example, a 1-inch wire (25 nH) has an impedance of 16 Ohms at 100 MHz.

SPEED OF SIGNALS

In air: 12 inches/nsec

In most PC board dielectrics: 6 inches/nsec

VSWR AND RETURN LOSS

$$VSWR \text{ given forward/reverse power } VSWR = \frac{1 + \sqrt{P_{rev}/P_{fwd}}}{1 - \sqrt{P_{rev}/P_{fwd}}}$$

$$VSWR \text{ given reflection coefficient } (\rho) \quad VSWR = \left| \frac{1 + \rho}{1 - \rho} \right|$$

$$\text{Reflection coefficient } (\rho), \text{ given } Z_1, Z_2 \text{ Ohms } \quad \rho = \left| \frac{Z_1 - Z_2}{Z_1 + Z_2} \right|$$

$$\text{Reflection coefficient } (\rho), \text{ given fwd/rev power } \quad \rho = \sqrt{\frac{P_{rev}}{P_{fwd}}}$$

RETURN LOSS, GIVEN FORWARD/REVERSE POWER

$$RL(dB) = -10 \log\left(\frac{P_{OUT}}{P_{IN}}\right)$$

REFERENCES & TOOLS

RETURN LOSS, GIVEN VSWR

$$RL(dB) = -20\log\left(\frac{VSWR - 1}{VSWR + 1}\right)$$

Return Loss, given reflection coefficient (ρ)

$$RL(dB) = -20\log(\rho)$$

E-FIELD FROM DIFFERENTIAL-MODE CURRENT

$$|E_{D,max}| = 2.63 * 10^{-14} \frac{|I_D|f^2Ls}{d}$$

ID = differential-mode current in loop (A)

f = frequency (Hz)

L = length of loop (m)

s = spacing of loop (m)

d = measurement distance (3 m or 10 m, typ.)

(Assumption that the loop is electrically small and measured over a reflecting surface)

E-FIELD FROM COMMON-MODE CURRENT

$$|E_{C,max}| = 1.257 * 10^{-6} \frac{|I_C|fL}{d}$$

IC = common-mode current in wire (A)

f = frequency (Hz)

L = length of wire (m)

d = measurement distance (3 m or 10 m, typ.) (Assumption that the wire is electrically short)

TEMPERATURE CONVERSIONS

Celsius to Fahrenheit: $^{\circ}C = 5/9(^{\circ}F - 32)$

Fahrenheit to Celsius: $^{\circ}F = 9/5(^{\circ}C) + 32$

ANTENNA (FAR FIELD) RELATIONSHIPS

Gain, dBi to numeric $Gain_{numeric} = 10^{dBi/10}$

Gain, numeric to dBi $dBi = 10\log(Gain_{numeric})$

Gain, dBi to Antenna Factor $AF = 20\log(MHz) - dBi - 29.79$

Antenna Factor to gain in dBi $dBi = 20\log(MHz) - AF - 29.79$

Field Strength given watts, numeric gain, distance in meters

$$V/m = \frac{\sqrt{30 * watts * Gain_{numeric}}}{meters}$$

Field Strength given watts, dBi gain, distance in meters

$$V/m = \frac{\sqrt{30 * watts * 10^{(dBi/10)}}}{meters}$$

Transmit power required, given desired V/m, antenna numeric gain, distance in meters

$$Watts = \frac{(V/m * meters)^2}{30 * Gain_{numeric}}$$

Transmit power required, given desired V/m, antenna dBi gain, distance in meters

$$Watts = \frac{(V/m * meters)^2}{30 * 10^{dBi/10}}$$

PC BOARD EQUATIONS

1 oz. copper = 1.4 mils = 0.036 mm

0.5 oz. copper = 0.7 mils = 0.018 mm

Convert mils to mm: multiply by 0.0254 mm/mil

Convert mm to mils: multiply by 39.4 mil/mm

Signal velocity in free space: approx. 12 in/ns

Signal velocity in FR-4: approx. 6 in/ns

REFERENCES & TOOLS

WORKING WITH DB

The decibel is always a ratio

Power Gain = P_{out}/P_{in}

Power Gain(dB) = $10\log(P_{out} / P_{in})$

Voltage Gain(dB) = $20\log(V_{out}/V_{in})$

Current Gain(dB) = $20\log(I_{out}/I_{in})$

We commonly work with:

dBm (referenced to 1 mW)

dB μ V (referenced to 1 μ V)

dB μ A (referenced to 1 μ A)

Power Ratios

3 dB = double (or half) the power

10 dB = 10X (or /10) the power

Voltage/Current Ratios

6 dB = double (or half) the voltage/current
20 dB = 10X (or /10) the voltage/current

DBM, DB μ V, DB μ A (CONVERSION)

Volts to dBV:	$\text{dBV} = 20\log(V)$
Volts to dB μ V:	$\text{dB}\mu\text{V} = 20\log(V) + 120$
dBV to Volts:	$V = 10^{(\text{dBV}/20)}$
dB μ V to Volts:	$V = 10^{((\text{dB}\mu\text{V}-120)/20)}$
dBV to dB μ V:	$\text{dB}\mu\text{V} = \text{dBV} + 120$
dB μ V to dBV:	$\text{dBV} = \text{dB}\mu\text{V} - 120$

Note: For current relationships, substitute A for V

FIELD STRENGTH EQUATIONS

dB μ V/m to V/m:	$V/m = 10^{((\text{dB}\mu\text{V}/m)-120)/20}$
V/m to dB μ V/m:	$\text{dB}\mu\text{V}/m = 20\log(V/m) + 120$
dB μ V/m to dB μ A/m:	$\text{dB}\mu\text{A}/m = \text{dB}\mu\text{V}/m - 51.5$
dB μ A/m to dB μ V/m:	$\text{dB}\mu\text{V}/m = \text{dB}\mu\text{A}/m + 51.5$
dB μ A/m to dB μ T:	$\text{dB}\mu\text{T} = \text{dB}\mu\text{A}/m + 2$
dB μ T to dB μ A/m:	$\text{dB}\mu\text{A}/m = \text{dB}\mu\text{T} - 2$
μ T to A/m:	$A/m = \mu\text{T}/1.25$
A/m to μ T:	$\mu\text{T} = 1.25 * A/m$

DBM TO DB μ V CHART

dBm	dB μ V
20	127
10	117
0	107
-10	97
-20	87
-30	77
-40	67
-50	57
-60	47
-70	37
-80	27
-90	17
-100	7

A common formula for converting default spectrum analyzer amplitudes (dBm) to the limits as shown in the emissions standards (dB μ V):

dBm to dB μ V, use: $\text{dB}\mu\text{V} = \text{dBm} + 107$

WAVELENGTH EQUATIONS (FREE SPACE)

Wavelength(m) = 300/f(MHz)

Half-wavelength(ft.) = 468/f(MHz)

RESONANCE OF STRUCTURES

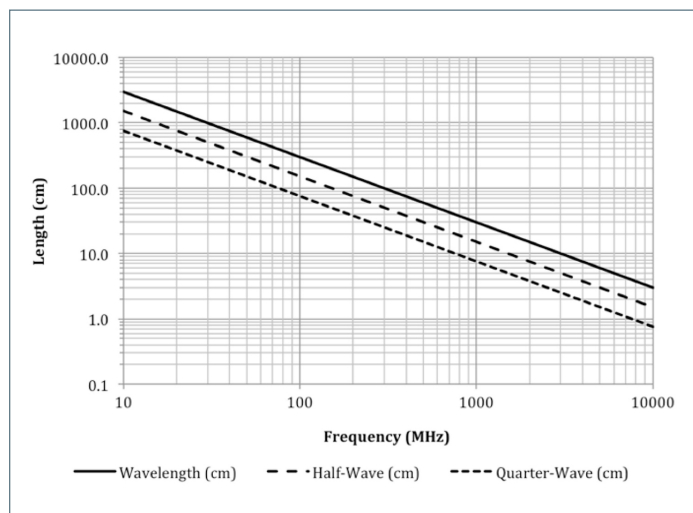

Use this handy chart for determining the resonant frequency versus cable or slot length in free space. Half-wavelength slots or cables simulate dipole antennas and are particularly troublesome. Image Source: Patrick André.

DIPOLE RADIATION VERSUS LENGTH

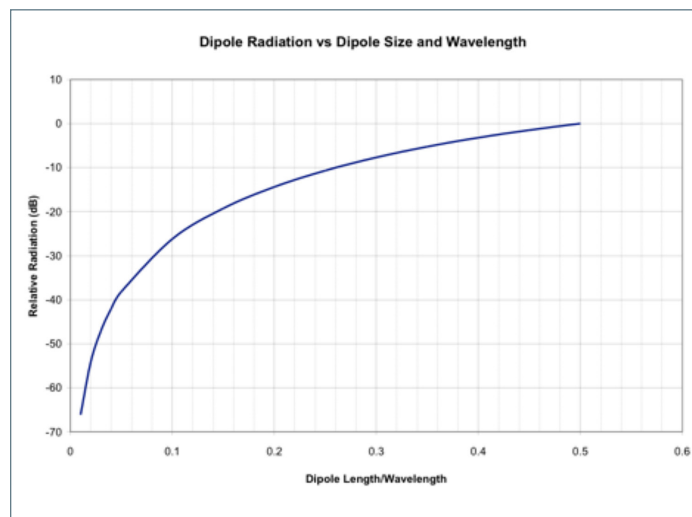

Use this chart to for determining the relative radiation versus size in wavelength. Image Source: Bruce Archambeault.

For example, a wire or slot whose length is 0.2 wavelength at a particular frequency, would radiate about 15 dB down from the equivalent half-wavelength wire or slot.



COMMON SYMBOLS

A	Amperes, unit of electrical current
AC	Alternating Current
AM	Amplitude modulated
dBm	dB with reference to 1 mW
dBμA	dB with reference to 1 μ A
dBμV	dB with reference to 1 μ V
DC	Direct Current
E	"E" is the electric field component of an electromagnetic field.
E/M	Ratio of the electric field (E) to the magnetic field (H), in the far-field this is the characteristic impedance of free space, approximately 377 Ω
EM	Electromagnetic
EMC	Electromagnetic compatibility
EMI	Electromagnetic Interference
FM	Frequency modulated
GHz	Gigahertz, one billion Hertz (1,000,000,000 Hertz)
H	"H" is the magnetic field component of an electromagnetic field.
Hz	Hertz, unit of measurement for frequency
I	Electric current
kHz	Kilohertz, one thousand Hertz (1,000 Hertz)
λ	Lambda, symbol for wavelength
MHz	Megahertz, one million Hertz (1,000,000 Hertz)
mil	Unit of length, one thousandth of an inch
mW	Milliwatt (0.001 Watt)
mW/cm²	Milliwatts per square centimeter, a unit for power density
Pd	Power density, unit of measurement of power per unit area (W/m ² or mW/cm ²)
R	Resistance
RF	Radio Frequency
RFI	Radio Frequency Interference
V	Volts, unit of electric voltage potential
V/m	Volts per meter, unit of electric field strength
W/m²	Watts per square meter, a unit for power density, one W/m ² equals 0.1 mW/cm ²
Ω	Ohms, unit of resistance

Ref: ANSI/IEEE 100-1984, IEEE Standard Dictionary of Electrical and Electronics Terms, 1984.

Providing Solutions for EMC Compliance

SCHAFFNER
shaping electrical power



ACRONYMS

AF	(Antenna Factor) - The ratio of the received field strength to the voltage at the terminals of a receiving antenna. Units are 1/m.
ALC	(Absorber-Lined Chamber) - A shielded room with RF-absorbing material on the walls and ceiling. In many cases, the floor is reflective.
AM	(Amplitude Modulation) - A technique for putting information on a sinusoidal carrier signal by varying the amplitude of the carrier.
BCI	(Bulk Current Injection) - An EMC test where common-mode currents are coupled onto the power and communications cables of an EUT.
CE	(Conducted Emissions) - The RF energy generated by electronic equipment, which is conducted on power cables.
CE Marking	The marking signifying a product meets the required European Directives.
CENELEC	French acronym for the "European Committee for Electrotechnical Standardization".
CI	(Conducted Immunity) - A measure of the immunity to RF energy coupled onto cables and wires of an electronic product.
CISPR	French acronym for "Special International Committee on Radio Interference".
Conducted	Energy transmitted via cables or PC board connections.
Coupling Path	A structure or medium that transmits energy from a noise source to a victim circuit or system.
CS	(Conducted Susceptibility) - RF energy or electrical noise coupled onto I/O cables and power wiring that can disrupt electronic equipment.
CW	(Continuous Wave) - A sinusoidal waveform with a constant amplitude and frequency.
EMC	(Electromagnetic Compatibility) - The ability of a product to coexist in its intended electromagnetic environment without causing or suffering disruption or damage.
EMI	(Electromagnetic Interference) - When electromagnetic energy is transmitted from an electronic device to a victim circuit or system via radiated or conducted paths (or both) and which causes circuit upset in the victim.
EMP	(Electromagnetic Pulse) - Strong electromagnetic transients such as those created by lightning or nuclear blasts.
ESD	(Electrostatic Discharge) - A sudden surge in current (positive or negative) due to an electric spark or secondary discharge causing circuit disruption or component damage. Typically characterized by rise times less than 1 ns and total pulse widths on the order of microseconds.
ESL	(Equivalent Series Inductance) - Generally refers to the parasitic series inductance of a capacitor or inductor. It could also include the extra series inductance of any connecting traces or vias on a PC board.
ESR	(Equivalent Series Resistance) - Generally refers to the parasitic series resistance of a capacitor or inductor.
EU	European Union.
EUT	(Equipment Under Test) - The device being evaluated.
Far Field	When you get far enough from a radiating source the radiated field can be considered planar (or plane waves).
FCC	U.S. Federal Communications Commission.
FM	(Frequency Modulation) - A technique for putting information on a sinusoidal "carrier" signal by varying the frequency of the carrier.
IEC	International Electrotechnical Commission
ISM	(Industrial, Scientific and Medical equipment) - A class of electronic equipment including industrial controllers, test & measurement equipment, medical products and other scientific equipment.
ITE	(Information Technology Equipment) - A class of electronic devices covering a broad range of equipment including computers, printers and external peripherals; also includes, telecommunications equipment, and multi-media devices.

ACRONYMS

LISN	(Line Impedance Stabilization Network) - Used to match the 50-Ohm impedance of measuring receivers to the power line.
MLCC	(Multi-Layer Ceramic Capacitor) - A surface mount capacitor type often used as decoupling or energy storage capacitors in a power distribution network.
Near Field	When you are close enough to a radiating source that its field is considered spherical rather than planar.
Noise Source	A source that generates an electromagnetic perturbation or disruption to other circuits or systems.
OATS	(Open Area Test Site) - An outdoor EMC test site free of reflecting objects except a ground plane.
PDN	(Power Distribution Network) - The wiring and circuit traces from the power source to the electronic circuitry. This includes the parasitic components (R, L, C) of the circuit board, traces, bypass capacitance and any series inductances.
PLT	(Power Line Transient) - A sudden positive or negative surge in the voltage on a power supply input (DC source or AC line).
PI	(Power Integrity) - Refers to the quality of the energy transfer along the power supply circuitry from the voltage regulator module (VRM) to the die of the ICs. High switching noise or oscillations mean a low PI.
Radiated	Energy transmitted through the air via antenna or loops.
RFI	Radio Frequency Interference) - The disruption of an electronic device or system due to electromagnetic emissions at radio frequencies (usually a few kHz to a few GHz). Also EMI.
RE	(Radiated Emissions) - The energy generated by a circuit or equipment, which is radiated directly from the circuits, chassis and/or cables of equipment.
RI	Radiated Immunity) - The ability of circuits or systems to be immune from radiated energy coupled to the chassis, circuit boards and/or cables. Also Radiated Susceptibility (RS).
RF	(Radio Frequency) - A frequency at which electromagnetic radiation of energy is useful for communications.
RS	(Radiated Susceptibility) - The ability of equipment or circuits to withstand or reject nearby radiated RF sources. Also Radiated Immunity (RI).
SSCG	Spread Spectrum Clock Generation) - This technique takes the energy from a CW clock signal and spreads it out wider, which results in a lower effective amplitude for the fundamental and high-order harmonics. Used to achieve improved radiated or conducted emission margin to the limits.
SI	(Signal Integrity) - A set of measures of the quality of an electrical signal.
SSN	(Simultaneous Switching Noise) - Fast pulses that occur on the power bus due to switching transient currents drawn by the digital circuitry.
TEM	(Transverse Electromagnetic) - An electromagnetic plane wave where the electric and magnetic fields are perpendicular to each other everywhere and both fields are perpendicular to the direction of propagation. TEM cells are often used to generate TEM waves for radiated emissions (RE) or radiated immunity (RI) testing.
Victim	An electronic device, component or system that receives an electromagnetic disturbance, which causes circuit upset.
VRM	(Voltage Regulator Module) - A linear or switch-mode voltage regulator. Generally, there will be several of these mounted to a PC board in order to supply different levels of required voltages.
VSWR	(Voltage Standing Wave Ratio) - A measure of how well the load is impedance matched to its transmission line. This is calculated by dividing the voltage at the peak of a standing wave by the voltage at the null in the standing wave. A good match is less than 1.2:1.
XTALK	(Crosstalk) - A measure of the electromagnetic coupling from one circuit to another. This is a common problem between one circuit trace and another.

RECOMMENDED EMC BOOKS, MAGAZINES AND JOURNALS

2020 EMC Testing Guide

This guide offers insights and tools needed to plan for and prevent EMC failures before even entering the testing lab. <https://learn.interferencetechnology.com/2020-emc-testing-guide/>

2020 Europe EMC Guide

This guide features technical articles, reference materials, a company directory, and a products and services list for more than 10 countries. <https://learn.interferencetechnology.com/2020-europe-emc-guide/>

2020 Automotive EMC Guide

This guide features technical articles, reference materials, and a company directory focused on the EMI challenges that result from today's complex connected automotive systems. <https://learn.interferencetechnology.com/2021-automotive-emc-guide/>

2020 EMC Fundamentals Guide

The Fundamentals Guide and keep your project running smoothly by better understanding how to address EMI and EMC in the early design phases. <https://learn.interferencetechnology.com/2020-emc-fundamentals-guide/>

2020 IoT, Wireless, 5G EMC Guide

The 2020 IoT, Wireless, 5G EMC Guide includes content and reference material focused on providing the information required for designing and testing EMI-free wireless devices. <https://learn.interferencetechnology.com/2020-iot-wireless-5g-emc-guide/>

André and Wyatt,

EMI Troubleshooting Cookbook for Product Designers
SciTech Publishing, 2014. Includes chapters on product design and EMC theory & measurement. A major part of the content includes how to troubleshoot and mitigate all common EMC test failures.

Archambeault,

PCB Design for Real-World EMI Control
Kluwer Academic Publishers, 2002.

Armstrong,

EMC Design Techniques For Electronic Engineers
Armstrong/Nutwood Publications, 2010. A comprehensive treatment of EMC theory and practical product design and measurement applications.

Armstrong,

EMC For Printed Circuit Boards - Basic and Advanced Design and Layout Techniques
Armstrong/Nutwood Publications, 2010. A comprehensive treatment of PC board layout for EMC compliance.

ARRL,

The RFI Handbook
(3rd edition), 2010. Good practical book on radio frequency interference with mitigation techniques. Some EMC theory.

Bogatin,

Signal & Power Integrity - Simplified
Prentice-Hall, 2009 (2nd Edition). Great coverage of signal and power integrity from a fields viewpoint.

Brander, et al,

Trilogy of Magnetics - Design Guide for EMI Filter Design, SMPS & RF Circuits
Würth Elektronik, 2010. A comprehensive compilation of valuable design information and examples of filter, switch-mode power supply, and RF circuit design.

Goedbloed,

Electromagnetic Compatibility
Prentice-Hall, 1990. Good general text on EMC with practical experiments. May be out of print.

Kimmel and Gerke,

Electromagnetic Compatibility in Medical Equipment
IEEE Press, 1995. Good general product design information.

Mardiguian,

Controlling Radiated Emissions by Design
Springer, 2016. Good content on product design for compliance.

Kunkel,

Shielding of Electromagnetic Waves, Theory and Practice
Springer, 2019. Provides efficient ways for design engineers to apply electromagnetic theory in shielding of electrical and electronic equipment.

Hall, Hall, and McCall,

High-Speed Digital System Design - A Handbook of Interconnect Theory and Design Practices
Wiley, 2000.

RECOMMENDED EMC BOOKS, MAGAZINES AND JOURNALS

Joffe and Lock,

Grounds For Grounding

Wiley, 2010. This huge book includes way more topics on product design than the title suggests. Covers all aspects of grounding and shielding for products, systems, and facilities.

Johnson and Graham,

High-Speed Digital Design - A Handbook of Black Magic

Prentice-Hall, 1993. Practical coverage of high speed digital signals and measurement.

Johnson and Graham,

High-Speed Signal Propagation - Advanced Black Magic

Prentice-Hall, 2003. Practical coverage of high speed digital signals and measurement.

Ott,

Electromagnetic Compatibility Engineering

Wiley, 2009. The "bible" on EMC measurement, theory, and product design.

Paul,

Introduction to Electromagnetic Compatibility

Wiley, 2006 (2nd Edition). The one source to go to for an upper-level course on EMC theory.

Mardiguian,

EMI Troubleshooting Techniques

McGraw-Hill, 2000. Good coverage of EMI troubleshooting.

Montrose,

EMC Made Simple

Montrose Compliance Services, 2014. The content includes several important areas of EMC theory and product design, troubleshooting, and measurement.

Morrison,

Digital Circuit Boards - Mach 1 GHz

Wiley, 2012. Important concepts of designing high frequency circuit boards from a fields viewpoint.

Morrison,

Grounding And Shielding - Circuits and Interference

Wiley, 2016 (6th Edition). The classic text on grounding and shielding with up to date content on how RF energy flows through circuit boards.

Sandler,

Power Integrity - Measuring, Optimizing, and Troubleshooting Power Related Parameters in Electronics Systems

McGraw-Hill, 2014. The latest information on measurement and design of power distribution networks and how the network affects stability and EMC.

Slattery and Skinner,

Platform Interference in Wireless Systems - Models, Measurement, and Mitigation

Newnes Press, 2008. The first publication to publicize the issue of self-interference to on-board wireless systems.

Smith,

High Frequency Measurements and Noise in Electronic Circuits

Springer, 1993. A classic book on high frequency measurements, probing techniques, and EMC troubleshooting measurements.

Smith and Bogatin,

Principles of Power Integrity for PDN Design - Simplified

Prentice-Hall, 2017. Getting the power distribution network (PDN) design right is the key to reducing EMI.

Williams,

EMC For Product Designers

Newnes, 2017. Completely updated text on product design for EMC compliance.

Weston,

Electromagnetic Compatibility - Methods, Analysis, Circuits, and Measurement

CRC Press, 2017 (3rd Edition). A comprehensive text, encompassing both commercial and military EMC.

Witte,

Spectrum and Network Measurements

(2nd edition), SciTech Publishing, 2014. The best text around explaining the theory and usage of spectrum and network analyzers.

Wyatt and Jost,

Electromagnetic Compatibility (EMC) Pocket Guide

SciTech Publishing, 2013. A handy pocket-sized reference guide to EMC.

Wyatt and Gruber,

Radio Frequency (RFI) Pocket Guide

SciTech Publishing, 2015. A handy pocket-sized reference guide to radio frequency interference.

LINKEDIN GROUPS

Electromagnetic Compatibility Forum

Electromagnetics and Spectrum Engineering Group

EMC - Electromagnetic Compatibility

EMC Experts

EMC Troubleshooters

ESD Experts

Signal & Power Integrity Community

EMI/EMC Testing

For Industry Specific LinkedIn Groups, please see the Featured Industry sections on Wireless/5G/IoT, Automotive, and Military/Aerospace.



COVER YOUR BASES *With The* SIGNAL SOLUTION KIT

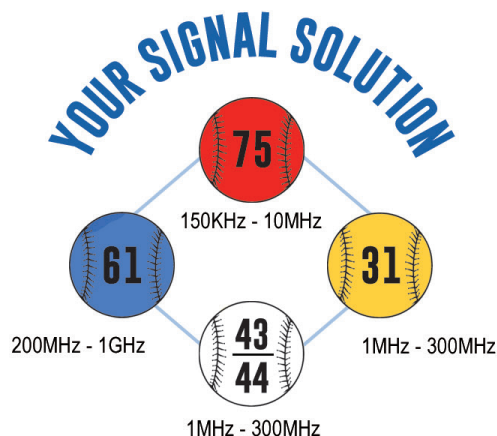

FORCE EMI OUT with Our All-Star Line-Up of "Snap-Its"
Featuring our most popular materials and sizes!



INTERFERENCE TECHNOLOGY DESIGN FUNDAMENTALS

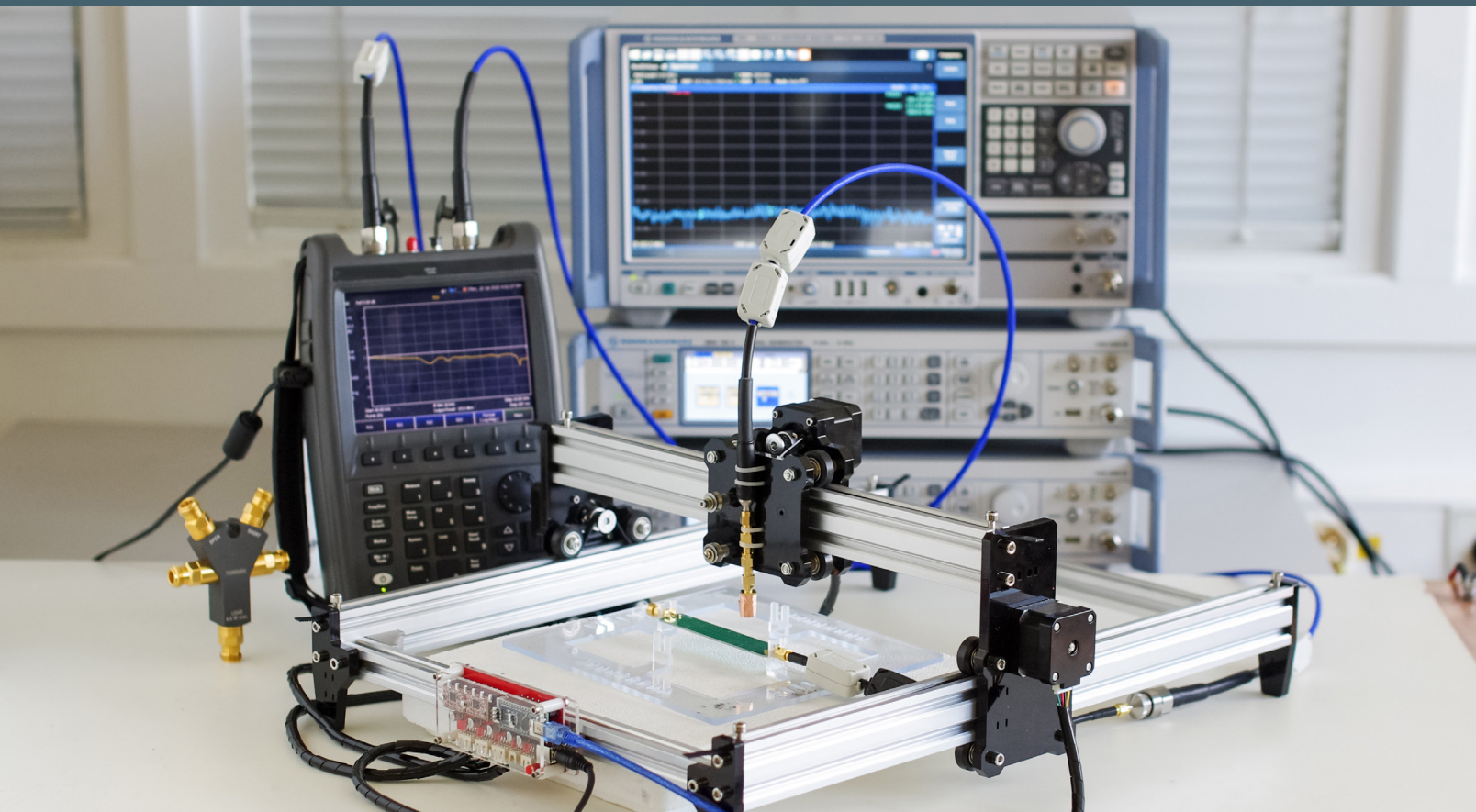

EMC EQUIPMENT MANUFACTURERS

Introduction

The following chart is a quick reference guide of test equipment and includes everything you'll need from the bare minimum required for key evaluation testing, probing, and troubleshooting, to setting up a full in-house pre-compliance or full compliance test lab. The list includes amplifiers, antennas, current probes, ESD simulators, LISNs, near field probes, RF signal generators, spectrum analyzers, EMI receivers, and TEM cells. Equipment rental companies are also listed. The products listed can help you evaluate radiated and conducted emissions, radiated and conducted immunity and a host of other immunity tests, such as ESD and EFT.



EMC Equipment Manufacturers		Type of Product/Service												
Manufacturer	Contact Information - URL	Antennas	Amplifiers	Near Field Probes	Current Probes	Spectrum Analyzers/EMF Receivers	ESD Simulators	LISNs	Radiated Immunity	Conducted Immunity	Pre-Compliance Test	TEM Cells	Rental Companies	RF Signal Generators
A.H. Systems	www.ahsystems.com	X	X		X						X			
Aaronia AG	www.aaronia.com	X	X			X					X			
Advanced Test Equipment Rentals	www.atecorp.com	X	X	X	X	X	X	X	X	X	X	X	X	X
Amplifier Research (AR)	www.arworld.us	X	X			X		X	X	X	X			X
Anritsu	www.anritsu.com					X					X			X
Electro Rent	www.electrorent.com		X			X	X	X	X	X	X		X	X
EM Test	www.emtest.com/home.php									X	X	X		
EMC Partner	www.emc-partner.com						X			X				
Empower RF Systems	www.empowerrf.com		X						X					
Fischer Custom Communications	www.fischercc.com			X	X			X			X			
Gauss Instruments	www.gauss-instruments.com/en/					X								
Haefley-Hipotronics	www.haefely-hipotronics.com						X			X				
Instrument Rental Labs	www.testequip.com		X			X	X	X	X	X	X		X	X
Keysight Technologies	www.keysight.com/main/home.jsp?cc=US&lc=eng			X		X		X			X			X
Microlease	www.microlease.com/us/home		X			X	X	X	X	X	X		X	X
Milmega	www.milmega.co.uk		X						X	X				
Narda/PMM	www.narda-sts.it/narda/default_en.asp	X	X			X		X	X	X	X			
Noiseken	www.noiseken.com						X			X	X			
Ophir RF	www.ophirrf.com		X							X				
Pearson Electronics	www.pearsonelectronics.com				X									
Rigol Technologies	www.rigolna.com		X	X	X	X					X			X
Rohde & Schwarz GmbH & Co. KG	www.rohde-schwarz.com	X	X	X	X	X		X	X	X	X			X
Rohde & Schwarz USA, Inc.	www.rohde-schwarz.com	X	X	X	X	X		X	X	X	X			X
Siglent Technologies	www.siglentamerica.com			X		X					X			X
Signal Hound	www.signalhound.com			X		X					X			X
Solar Electronics	www.solar-emc.com	X			X		X	X		X				
TekBox Technologies	www.tekbox.net		X	X				X			X	X		
Tektronix	www.tek.com			X		X					X			
Teseq	www.teseq.com/en/index.php		X		X		X		X	X	X	X		
Test Equity	www.testequity.com/leasing/		X			X	X	X	X	X	X		X	X
Thurlby Thandar (AIM-TTi)	www.aimtti.us					X					X			X
Toyotech (Toyo)	www.toyotechus.com/emc-electromagnetic-compatibility/	X	X			X		X	X		X			
TPI	www.rf-consultant.com													X
Transient Specialists	www.transientspecialists.com								X	X		X		
TRSRentelCo	www.trs-rentelco.com/SubCategory/EMC_Test_Equipment.aspx	X	X			X		X	X	X	X		X	X
Vectawave Technology	www.vectawave.com		X											
Windfreak Technologies	www.windfreaktech.com													X

COMMON COMMERCIAL, AUTOMOTIVE, MEDICAL, WIRELESS & MILITARY EMC STANDARDS

COMMERCIAL STANDARDS

The following are some of the most common commercial EMC standards. Most standards have a fee associated and most on the list are linked back to the source where they're available. If you're purchasing the printed version of this guide, then refer to the Standards Organizations in the References section for standards purchase information. Note that many Euro Norm (EN) versions of IEC standards may be purchased at a considerable discount from the Estonian Centre for Standardization, <https://www.evs.ee>.

FCC

<https://www.ecfr.gov>

Electronic Code of Federal Regulations (e-CFR)
CFR 47 - Part 15 (Radio Frequency Devices)

ANSI

<http://webstore.ansi.org>

Document Number	Title
C63.4	Methods of Measurement of Radio-Noise Emissions from Low-Voltage Electrical and Electronic Equipment in the Range of 9 kHz to 40 GHz

IEC

<https://webstore.iec.ch>

Document Number	Title
IEC 60601-1-2	Medical electrical equipment - Part 1-2: General requirements for basic safety and essential performance - Collateral Standard: Electromagnetic disturbances - Requirements and tests
IEC 60601-2-2	Medical electrical equipment - Part 2-2: Particular requirements for the basic safety and essential performance of high frequency surgical equipment and high frequency surgical accessories
IEC 60601-4-2	Medical electrical equipment - Part 4-2: Guidance and interpretation - Electromagnetic immunity: performance of medical electrical equipment and medical electrical systems
IEC 61000-3-2	Electromagnetic compatibility (EMC) - Part 3-2: Limits - Limits for harmonic current emissions (equipment input current ≤ 16 A per phase)
IEC 61000-3-3	Electromagnetic compatibility (EMC) - Part 3-3: Limits - Limitation of voltage changes, voltage fluctuations and flicker in public low-voltage supply systems, for equipment with rated current ≤ 16 A per phase and not subject to conditional connection
IEC 61000-4-2	Electromagnetic compatibility (EMC)- Part 4-2: Testing and measurement techniques - Electrostatic discharge immunity test
IEC 61000-4-3	Electromagnetic compatibility (EMC) - Part 4-3 : Testing and measurement techniques - Radiated, radio-frequency, electromagnetic field immunity test
IEC 61000-4-4	Electromagnetic compatibility (EMC) - Part 4-4 : Testing and measurement techniques - Electrical fast transient/burst immunity test

IEC 61000-4-5	Electromagnetic compatibility (EMC) - Part 4-5: Testing and measurement techniques - Surge immunity test
IEC 61000-4-6	Electromagnetic compatibility (EMC) - Part 4-6: Testing and measurement techniques - Immunity to conducted disturbances, induced by radio-frequency fields
IEC 61000-4-7	Electromagnetic compatibility (EMC) - Part 4-7: Testing and measurement techniques - General guide on harmonics and interharmonics measurements and instrumentation, for power supply systems and equipment connected thereto
IEC 61000-4-8	Electromagnetic compatibility (EMC) - Part 4-8: Testing and measurement techniques - Power frequency magnetic field immunity test
IEC 61000-4-9	Electromagnetic compatibility (EMC) - Part 4-9: Testing and measurement techniques - Impulse magnetic field immunity test
IEC 61000-4-10	Electromagnetic compatibility (EMC) - Part 4-10: Testing and measurement techniques - Damped oscillatory magnetic field immunity test
IEC 61000-4-11	Electromagnetic compatibility (EMC) - Part 4-11: Testing and measurement techniques - Voltage dips, short interruptions and voltage variations immunity tests
IEC 61000-4-12	Electromagnetic compatibility (EMC) - Part 4-12: Testing and measurement techniques - Ring wave immunity test
IEC 61000-6-1	Electromagnetic compatibility (EMC) - Part 6-1: Generic standards - Immunity standard for residential, commercial and light-industrial environments
IEC 61000-6-2	Electromagnetic compatibility (EMC) - Part 6-2: Generic standards - Immunity standard for industrial environments
IEC 61000-6-3	Electromagnetic compatibility (EMC) - Part 6-3: Generic standards - Emission standard for residential, commercial and light-industrial environments
IEC 61000-6-4	Electromagnetic compatibility (EMC) - Part 6-4: Generic standards - Emission standard for industrial environments
IEC 61000-6-5	Electromagnetic compatibility (EMC) - Part 6-5: Generic standards - Immunity for power station and substation environments
IEC 61000-6-7	Electromagnetic compatibility (EMC) - Part 6-7: Generic standards - Immunity requirements for equipment intended to perform functions in a safety-related system (functional safety) in industrial locations
IEC 61326-1	Electrical equipment for measurement, control and laboratory use – EMC requirements – Part 1: General requirements
IEC 61326-2-1	Electrical equipment for measurement, control and laboratory use - EMC requirements - Part 2-1: Particular requirements - Test configurations, operational conditions and performance criteria for sensitive test and measurement equipment for EMC unprotected applications
IEC 61326-2-2	Electrical equipment for measurement, control and laboratory use - EMC requirements - Part 2-2: Particular requirements - Test configurations, operational conditions and performance criteria for portable test, measuring and monitoring equipment used in low-voltage distribution systems
IEC 61326-2-3	Electrical equipment for measurement, control and laboratory use - EMC requirements - Part 2-3: Particular requirements - Test configuration, operational conditions and performance criteria for transducers with integrated or remote signal conditioning
IEC 61326-2-4	Electrical equipment for measurement, control and laboratory use - EMC requirements - Part 2-4: Particular requirements - Test configurations, operational conditions and performance criteria for insulation monitoring devices according to IEC 61557-8 and for equipment for insulation fault location according to IEC 61557-9
IEC 61326-2-5	Electrical equipment for measurement, control and laboratory use - EMC requirements - Part 2-5: Particular requirements - Test configurations, operational conditions and performance criteria for field devices with field bus interfaces according to IEC 61784-1

IEC 61326-2-6	Electrical equipment for measurement, control and laboratory use - EMC requirements - Part 2-6: Particular requirements - In vitro diagnostic (IVD) medical equipment
IEC 61326-3-1	Electrical equipment for measurement, control and laboratory use - EMC requirements - Part 3-1: Immunity requirements for safety-related systems and for equipment intended to perform safety-related functions (functional safety) - General industrial applications
IEC 61326-3-2	Electrical equipment for measurement, control and laboratory use - EMC requirements - Part 3-2: Immunity requirements for safety-related systems and for equipment intended to perform safety-related functions (functional safety) - Industrial applications with specified electromagnetic environment
IEC 61340-3-1	Electrostatics - Part 3-1: Methods for simulation of electrostatic effects - Human body model (HBM) electrostatic discharge test waveforms

CISPR

<https://webstore.iec.ch>

Document Number	Title
CISPR 11	Industrial, scientific and medical (ISM) radio-frequency equipment - Electromagnetic disturbance characteristics - Limits and methods of measurement
CISPR 12	Vehicles, boats and internal combustion engines - Radio disturbance characteristics - Limits and methods of measurement for the protection of off-board receivers
CISPR 13	Sound and television broadcast receivers and associated equipment - Radio disturbance characteristics - Limits and methods of measurement
CISPR 14-1	Electromagnetic compatibility - Requirements for household appliances, electric tools and similar apparatus - Part 1: Emission
CISPR 14-2	Electromagnetic compatibility – Requirements for household appliances, electric tools and similar apparatus – Part 2: Immunity – Product family standard
CISPR 15	Limits and methods of measurement of radio disturbance characteristics of electrical lighting and similar equipment
CISPR 16-1-1	Specification for radio disturbance and immunity measuring apparatus and methods - Part 1-1: Radio disturbance and immunity measuring apparatus - Measuring apparatus
CISPR 16-1-2	Specification for radio disturbance and immunity measuring apparatus and methods - Part 1-2: Radio disturbance and immunity measuring apparatus - Coupling devices for conducted disturbance measurements
CISPR 16-1-3	Specification for radio disturbance and immunity measuring apparatus and methods - Part 1-3: Radio disturbance and immunity measuring apparatus - Ancillary equipment - Disturbance power
CISPR 16-1-4	Specification for radio disturbance and immunity measuring apparatus and methods - Part 1-4: Radio disturbance and immunity measuring apparatus - Antennas and test sites for radiated disturbance measurements
CISPR 16-1-5	Specification for radio disturbance and immunity measuring apparatus and methods - Part 1-5: Radio disturbance and immunity measuring apparatus - Antenna calibration sites and reference test sites for 5 MHz to 18 GHz
CISPR 16-1-6	Specification for radio disturbance and immunity measuring apparatus and methods - Part 1-6: Radio disturbance and immunity measuring apparatus - EMC antenna calibration
CISPR 16-2-1	Specification for radio disturbance and immunity measuring apparatus and methods - Part 2-1: Methods of measurement of disturbances and immunity - Conducted disturbance measurements

CISPR 16-2-2	Specification for radio disturbance and immunity measuring apparatus and methods - Part 2-2: Methods of measurement of disturbances and immunity - Measurement of disturbance power
CISPR 16-2-3	Specification for radio disturbance and immunity measuring apparatus and methods - Part 2-3: Methods of measurement of disturbances and immunity - Radiated disturbance measurements
CISPR 16-2-4	Specification for radio disturbance and immunity measuring apparatus and methods - Part 2-4: Methods of measurement of disturbances and immunity - Immunity measurements
CISPR TR 16-2-5	Specification for radio disturbance and immunity measuring apparatus and methods - Part 2-5: In situ measurements for disturbing emissions produced by physically large equipment
CISPR TR 16-3	Specification for radio disturbance and immunity measuring apparatus and methods - Part 3: CISPR technical reports
CISPR TR 16-4-1	Specification for radio disturbance and immunity measuring apparatus and methods - Part 4-1: Uncertainties, statistics and limit modelling - Uncertainties in standardized EMC tests
CISPR 16-4-2	Specification for radio disturbance and immunity measuring apparatus and methods - Part 4-2: Uncertainties, statistics and limit modelling - Measurement instrumentation uncertainty
CISPR TR 16-4-3	Specification for radio disturbance and immunity measuring apparatus and methods - Part 4-3: Uncertainties, statistics and limit modelling - Statistical considerations in the determination of EMC compliance of mass-produced products
CISPR TR 16-4-4	Specification for radio disturbance and immunity measuring apparatus and methods - Part 4-4: Uncertainties, statistics and limit modelling - Statistics of complaints and a model for the calculation of limits for the protection of radio services
CISPR TR 16-4-5	Specification for radio disturbance and immunity measuring apparatus and methods - Part 4-5: Uncertainties, statistics and limit modelling - Conditions for the use of alternative test methods
CISPR 17	Methods of measurement of the suppression characteristics of passive EMC filtering devices
CISPR TR 18-1	Radio interference characteristics of overhead power lines and high-voltage equipment - Part 1: Description of phenomena
CISPR TR 18-2	Radio interference characteristics of overhead power lines and high-voltage equipment - Part 2: Methods of measurement and procedure for determining limits
CISPR TR 18-3	Radio interference characteristics of overhead power lines and high-voltage equipment - Part 3: Code of practice for minimizing the generation of radio noise
CISPR 20	Sound and television broadcast receivers and associated equipment - Immunity characteristics - Limits and methods of measurement (to be withdrawn July 2021)
CISPR 24	Information technology equipment - Immunity characteristics - Limits and methods of measurement (to be withdrawn July 2021)
CISPR 25	Vehicles, boats and internal combustion engines - Radio disturbance characteristics - Limits and methods of measurement for the protection of on-board receivers
CISPR 32	Electromagnetic compatibility of multimedia equipment – Emission requirements
CISPR 35	Electromagnetic compatibility of multimedia equipment - Immunity requirements

AUTOMOTIVE ELECTROMAGNETIC COMPATIBILITY STANDARDS

The following abbreviated list of automotive EMC standards was developed by Dr. Todd Hubing, Professor Emeritus of Clemson University Vehicular Electronics Lab (http://www.cvel.clemson.edu/auto/auto_emc_standards.html). A few of these standards have been made public and are linked below, but many others are considered company confidential and are only available to approved automotive vendors or test equipment manufacturers. While several standards are linked on this list, an internet search may help locate additional documents that have been made public. For a more complete list, refer to the link above. Permission to republish has been granted.

CISPR (AUTOMOTIVE EMISSIONS REQUIREMENTS)

<https://webstore.iec.ch>

Document Number	Title
CISPR 12	Vehicles, boats, and internal combustion engine driven devices - Radio disturbance characteristics - Limits and methods of measurement for the protection of receivers except those installed in the vehicle/boat/device itself or in adjacent vehicles/boats/devices
CISPR 25	Radio disturbance characteristics for the protection of receivers used on board vehicles, boats, and on devices - Limits and methods of measurement

ISO (AUTOMOTIVE IMMUNITY REQUIREMENTS)

<https://www.iso.org>

Document Number	Title
ISO 7637-1	Road vehicles -- Electrical disturbances from conduction and coupling -- Part 1: Definitions and general considerations
ISO 7637-2	Road vehicles -- Electrical disturbances from conduction and coupling -- Part 2: Electrical transient conduction along supply lines only
ISO 7637-3	Road vehicles -- Electrical disturbance by conduction and coupling -- Part 3: Vehicles with nominal 12 V or 24 V supply voltage -- Electrical transient transmission by capacitive and inductive coupling via lines other than supply lines
ISO/TR 10305-1	Road vehicles -- Calibration of electromagnetic field strength measuring devices -- Part 1: Devices for measurement of electromagnetic fields at frequencies > 0 Hz
ISO/TR 10305-2	Road vehicles -- Calibration of electromagnetic field strength measuring devices -- Part 2: IEEE standard for calibration of electromagnetic field sensors and probes, excluding antennas, from 9 kHz to 40 GHz
ISO 10605	Road vehicles -- Test methods for electrical disturbances from electrostatic discharge
ISO/TS 21609	Road vehicles -- (EMC) guidelines for installation of aftermarket radio frequency transmitting equipment
ISO 11451-1	Road vehicles -- Vehicle test methods for electrical disturbances from narrowband radiated electromagnetic energy -- Part 1: General principles and terminology
ISO 11451-2	Road vehicles -- Vehicle test methods for electrical disturbances from narrowband radiated electromagnetic energy -- Part 2: Off-vehicle radiation sources
ISO 11451-3	Road vehicles -- Electrical disturbances by narrowband radiated electromagnetic energy -- Vehicle test methods -- Part 3: On-board transmitter simulation
ISO 11451-4	Road vehicles -- Vehicle test methods for electrical disturbances from narrowband radiated electromagnetic energy -- Part 4: Bulk current injection (BCI)

ISO 11452-4	Road vehicles -- Component test methods for electrical disturbances from narrowband radiated electromagnetic energy -- Part 4: Bulk current injection (BCI)
ISO 11452-7	Road vehicles -- Component test methods for electrical disturbances from narrowband radiated electromagnetic energy -- Part 7: Direct radio frequency (RF) power injection
ISO 11452-8	Road vehicles -- Component test methods for electrical disturbances from narrowband radiated electromagnetic energy -- Part 8: Immunity to magnetic fields
ISO 11452-10	Road vehicles -- Component test methods for electrical disturbances from narrowband radiated electromagnetic energy -- Part 10: Immunity to conducted disturbances in the extended audio frequency range

SAE (AUTOMOTIVE EMISSIONS AND IMMUNITY)

<http://standards.sae.org>

Document Number	Title
J1113/1	Electromagnetic Compatibility Measurement Procedures and Limits for Components of Vehicles, Boats (Up to 15 M), and Machines (Except Aircraft) (50 Hz to 18 Ghz)
J1113/2	Electromagnetic Compatibility Measurement Procedures and Limits for Vehicle Components (Except Aircraft)--Conducted Immunity, 15 Hz to 250 kHz--All Leads
J1113/4	Immunity to Radiated Electromagnetic Fields-Bulk Current Injection (BCI) Method
J1113/11	Immunity to Conducted Transients on Power Leads
J1113/12	Electrical Interference by Conduction and Coupling - Capacitive and Inductive Coupling via Lines Other than Supply Lines
J1113/13	Electromagnetic Compatibility Measurement Procedure for Vehicle Components - Part 13: Immunity to Electrostatic Discharge
J1113/21	Electromagnetic Compatibility Measurement Procedure for Vehicle Components - Part 21: Immunity to Electromagnetic Fields, 30 MHz to 18 GHz, Absorber-Lined Chamber
J1113/26	Electromagnetic Compatibility Measurement Procedure for Vehicle Components - Immunity to AC Power Line Electric Fields
J1113/27	Electromagnetic Compatibility Measurements Procedure for Vehicle Components - Part 27: Immunity to Radiated Electromagnetic Fields - Mode Stir Reverberation Method
J1113/28	Electromagnetic Compatibility Measurements Procedure for Vehicle Components--Part 28--Immunity to Radiated Electromagnetic Fields--Reverberation Method (Mode Tuning)
J1752/1	Electromagnetic Compatibility Measurement Procedures for Integrated Circuits-Integrated Circuit EMC Measurement Procedures-General and Definition
J1752/2	Measurement of Radiated Emissions from Integrated Circuits -- Surface Scan Method (Loop Probe Method) 10 MHz to 3 GHz
J1752/3	Measurement of Radiated Emissions from Integrated Circuits -- TEM/Wideband TEM (GTEM) Cell Method; TEM Cell (150 kHz to 1 GHz), Wideband TEM Cell (150 kHz to 8 GHz)
J551/5	Performance Levels and Methods of Measurement of Magnetic and Electric Field Strength from Electric Vehicles, Broadband, 9 kHz To 30 MHz
J551/15	Vehicle Electromagnetic Immunity--Electrostatic Discharge (ESD)

J551/16	Electromagnetic Immunity - Off-Vehicle Source (Reverberation Chamber Method) - Part 16 - Immunity to Radiated Electromagnetic Fields
J551/17	Vehicle Electromagnetic Immunity -- Power Line Magnetic Fields
J1812	Function Performance Status Classification for EMC Immunity Testing
J2628	Characterization--Conducted Immunity
J2556	Radiated Emissions (RE) Narrowband Data Analysis--Power Spectral Density (PSD)

GM

<https://global.ihs.com>

Document Number	Title
GMW3091	General Specification for Vehicles, Electromagnetic Compatibility (EMC)-Engl; Revision H; Supersedes GMI 12559 R and GMI 12559 V
GMW3097	General Specification for Electrical/Electronic Components and Subsystems, Electromagnetic Compatibility-Engl; Revision H; Supersedes GMW12559, GMW3100, GMW12002R AND GMW12002V
GMW3103	General Specification for Electrical/Electronic Components and Subsystems, Electromagnetic Compatibility Global EMC Component/Subsystem Validation Acceptance Process-Engl; Revision F; Contains Color; Replaces GMW12003, GMW12004 and GMW3106

FORD

<https://www.fordemc.com>

Document Number	Title
EMC-CS-2009.1	Component EMC Specification EMC-CS-2009.1
FORD F-2	Electrical and Electronics System Engineering
FORD WSF-M22P5-A1	Printed Circuit Boards, PTF, Double Sided, Flexible

DaimlerChrysler

Document Number	Title
DC-10614	EMC Performance Requirements - Components
DC-10615	Electrical System Performance Requirements for Electrical and Electronic Components
DC-11224	EMC Performance Requirements -- Components
DC-11225	EMC Supplemental Information and Alternative Component Requirements
DC-11223	EMC Performance Requirements -- Vehicle

Automotive Electromagnetic Compatibility Standards From

<https://cecas.clemson.edu/cvel/emc/>

MEDICAL STANDARDS

COLLATERAL STANDARDS

<https://www.webstore.iec.ch>

Document Number	Title
IEC 60601-1-1	Safety requirements for medical electrical systems
IEC 60601-1-2	Electromagnetic disturbances - requirements and tests
IEC 60601-1-3	Radiation protection in diagnostic x-ray equipment
IEC 60601-1-6	General requirements for basic safety and essential performance - Usability
IEC 60601-1-8	General requirements for basic safety and essential performance - Alarm systems
IEC 60601-1-9	Requirements for environmentally conscious design
IEC 60601-1-10	Requirements for the development of physiologic closed-loop controllers
IEC 60601-1-11	Medical electrical equipment and medical electrical systems used in the home healthcare environment
IEC 60601-1-12	Medical electrical equipment and medical electrical systems used in the medical services environment

OTHER RELEVANT STANDARDS

<https://www.webstore.iec.ch>

Document Number	Title
CISPR 11	Emission requirements for ISM equipment
IEC 60601-1	General requirements for basic safety and essential performance
IEC TR 60601-4-2	Electromagnetic immunity performance
IEC TR 60601-4-3	Considerations of unaddressed safety aspects in the third edition of IEC 60601-1
IEC TR 62354	General testing procedures for medical electrical equipment
ISO 14708-1	Active implantable medical devices

For more extensive listings of medical standards, download the 2020 Medical EMC Guide:

<https://learn.interferencetechnology.com/2020-medical-emc-guide/>

COMMON WIRELESS STANDARDS

ETSI STANDARDS

<https://www.etsi.org>

Document Number	Title
ETSI EN 300 220	Electromagnetic compatibility and Radio spectrum Matters (ERM); Short Range Devices (SRD); Radio equipment to be used in the 25MHz to 1000MHz frequency range with power levels ranging up to 500mW
ETSI EN 300 328	Electromagnetic compatibility and Radio Spectrum Matters (ERM); Wideband transmission systems; Data transmission equipment operating in the 2.4 GHz ISM band and using wide band modulation techniques; Harmonized EN covering essential requirements under article 3.2 of the R&TTE Directive
ETSI EN 300 330	Electromagnetic compatibility and Radio spectrum Matters (ERM); Short Range Devices (SRD); Radio equipment to be used in the 9kHz to 25MHz frequency range and inductive loop systems in the 9kHz to 30MHz frequency range
ETSI EN 300 440	Electromagnetic compatibility and Radio spectrum Matters (ERM); Short Range Devices (SRD); Radio equipment to be used in the 1GHz to 40GHz frequency range
ETSI EN 301 489-3	Electromagnetic compatibility and Radio spectrum Matters (ERM); Electromagnetic Compatibility (EMC) standard for radio equipment and services; Part 3: Specific conditions for Short Range Devices (SRD) operating on frequencies between 9kHz and 40GHz
ETSI EN 301 489-17	Electromagnetic compatibility and Radio spectrum Matters (ERM); Electromagnetic Compatibility (EMC) standard for radio equipment and services; Part 17: Specific conditions for Wideband data and HIPERLAN equipment
ETSI EN 301 893	Broadband Radio Access Networks (BRAN); 5 GHz high performance RLAN; Harmonized EN covering essential requirements of article 3.2 of the R&TTE Directive
ETSI EN 303 413	GPS receivers
ETSI EN 303 417	Wireless Power Transfer

COMMON MILITARY RELATED DOCUMENTS AND STANDARDS

The following references are not intended to be all inclusive, but rather a representation of available sources of additional information and point of contacts. Downloadable from: <http://everyspec.com>.

Document Number	Title
MIL-HDBK-235-1	Military Operational Electromagnetic Environment Profiles Part 1C General Guidance, 1 Oct 2010
MIL-HDBK-1857	Grounding, Bonding and Shielding Design Practices, 27 Mar 1998
MIL-STD-220C	Test Method Standard Method of Insertion Loss Measurement, 14 May 2009
MIL-STD-449D	Radio Frequency Spectrum Characteristics, Measurement of, 22 Feb 1973
MIL-STD-461F	Requirements for the Control of Electromagnetic Interference Characteristics of Subsystems and Equipment, 10 Dec 2007
MIL-STD-461G	Requirements for the Control of Electromagnetic Interference Characteristics of Subsystems and Equipment, 11 Dec 2015
MIL-STD-464C	Electromagnetic Environmental Effects Requirements for Systems, 01 Dec 2010

MIL-STD-1541A	Electromagnetic Compatibility Requirements for Space Systems, 30 Dec 1987
MIL-STD-1542B	Electromagnetic Compatibility and Grounding Requirements for Space System Facilities, 15 Nov 1991
MIL-STD-1605A	Procedures for Conducting a Shipboard Electromagnetic Interference (EMI) Survey (Surface Ships), 08 Oct 2009
DoDI 3222.03	DoD Electromagnetic Environmental Effects (E3) Program, 24 Aug 2014

AEROSPACE STANDARDS

AIAA STANDARDS

<http://www.aiaa.org/default.aspx>

Document Number	Title
S-121-2009	Electromagnetic Compatibility Requirements for Space Equipment and Systems

RTCA STANDARDS

www.rtca.org/

Document Number	Title
DO-160G	Environmental Conditions and Test Procedures for Airborne Equipment
DO-160G Change 1	Environmental Conditions and Test Procedures for Airborne Equipment
DO-233	Portable Electronic Devices Carried on Board Aircraft
DO-235B	Assessment of Radio Frequency Interference Relevant to the GNSS L1 Frequency Band
DO-292	Assessment of Radio Frequency Interference Relevant to the GNSS L5/E5A Frequency Band
DO-294C	Guidance on Allowing Transmitting Portable Electronic Devices (T-PEDs) on Aircraft
DO-307	Aircraft Design and Certification for Portable Electronic Device (PED) Tolerance
DO-357	User Guide: Supplement to DO-160G
DO-363	Guidance for the Development of Portable Electronic Devices (PED) Tolerance for Civil Aircraft
DO-364	Minimum Aviation System Performance Standards (MASPS) for Aeronautical Information/ Meteorological Data Link Services
DO-363	Guidance for the Development of Portable Electronic Devices (PED) Tolerance for Civil Aircraft
DO-307A	Aircraft Design and Certification for Portable Electronic Device (PED) Tolerance

SAE STANDARDS

www.sae.org/

Document Number	Title
ARP 5583A	Guide to Certification of Aircraft in a High Intensity Radiation (HIRF) Environment

REFERENCES

(ARTICLES, STANDARDS, BOOKS, MINI GUIDES, WEBSITES, & LINKEDIN GROUPS)

LINKS TO LONGER ARTICLES

DiBiase, Electromagnetic Interference Sources and Their Most Significant Effects, 2011

<https://interferencetechnology.com/electromagnetic-interference-sources-and-their-most-significant-effects/>

Duff, Designing Electronic Systems for EMC: Grounding for the Control of EMI, 2011

<https://interferencetechnology.com/designing-electronic-systems-for-emc-grounding-for-the-control-of-emi-3/>

Armstrong, Fundamentals of EMC Design: Our Products Are Trying to Help Us, 2012

<https://interferencetechnology.com/fundamentals-of-emc-design-our-products-are-trying-to-help-us-3/>

Forns, EMC Basics: Designing to Prevent EMI in Electronic Devices, 2014

<https://interferencetechnology.com/new-techniques-shielding-emi/>

Lee, Basics on Designing for EMC Compliance, 2012

<https://interferencetechnology.com/basics-on-designing-for-emc-compliance/>

Tabatabaei, Clocking Strategies for EMI Reduction, 2010

<https://interferencetechnology.com/clocking-strategies-for-emi-reduction/>

McCune, CMOS Is Different: PCB Design for Both Low Noise and Low EMI, 2013

<https://interferencetechnology.com/cmos-is-different-pcb-design-for-both-low-noise-and-low-emi/>

Armstrong, Cost-Effective EMC Design by Working With the Laws of Physics (Webinar), 2013

<https://interferencetechnology.com/watch-our-webinar-on-cost-effective-emc-design-by-working-with-the-laws-of-physics/>

EMC STANDARDS ORGANIZATIONS

American National Standards Institute

<http://www.ansi.org>

ANSI Accredited C63

<http://www.c63.org>

Asia Pacific Laboratory Accreditation Cooperation (APLAC)

<http://www.aplac.org>

BSMI (Taiwan)

<https://www.bsmi.gov.tw/wSite/xslgip/chinese/index.html>

CISPR

http://www.iec.ch/emc/iec_emc/iec_emc_players_cispr.htm

CNCA (China)

<http://www.cnca.gov.cn/cnca/cncatest/20040420/column/227.htm>

Electromagnetic Compatibility Industry Association (UK)

<http://www.emcia.org>

FDA Center for Devices & Radiological Health (CDRH)

<https://www.fda.gov/MedicalDevices/default.htm>

Federal Communications Commission (FCC)

<http://www.fcc.gov>

Gosstandart (Russia)

<http://gosstandart.gov.by/en-US/index.php>

IEC

<http://www.iec.ch/index.htm>

IEEE Standards Association

<http://www.standards.ieee.org>

IEEE EMC Society Standards Development Committee (SDCOM)

<https://standards.ieee.org/project/2665.html>

Industry Canada (Certifications and Standards)

http://www.ic.gc.ca/eic/site/smt-gst.nsf/eng/h_sf06165.html

ISO (International Organization for Standards)

<https://www.iso.org/home.html>

RTCA

<https://www.rtca.org>

SAE EMC Standards Committee

<http://www.sae.org>

VCCI (Japan, Voluntary Control Council for Interference)

http://www.vcci.jp/vcci_e/

REFERENCES

(ARTICLES, STANDARDS, BOOKS, MINI GUIDES, WEBSITES, & LINKEDIN GROUPS)

RECOMMENDED BOOKS

André and Wyatt

EMI Troubleshooting Cookbook for Product Designers

SciTech Publishing, 2014. Includes chapters on product design and EMC theory & measurement. A major part of the content includes how to troubleshoot and mitigate all common EMC test failures.

Archambeault

PCB Design for Real-World EMI Control
Kluwer Academic Publishers, 2002.

Bogatin

Signal & Power Integrity - Simplified

Prentice-Hall, 2018 (3rd Edition). Great coverage of signal and power integrity from a fields viewpoint.

Hall, Hall, and McCall

High-Speed Digital System Design - A Handbook of Interconnect Theory and Design Practices
Wiley, 2000.

Joffe and Lock

Grounds For Grounding

Wiley, 2010. This huge book includes way more topics on product design than the title suggests. Covers all aspects of grounding and shielding for products, systems, and facilities.

Johnson and Graham

High-Speed Digital Design - A Handbook of Black Magic

Prentice-Hall, 1993. Practical coverage of high speed digital signals and measurement.

Johnson and Graham

High-Speed Signal Propagation - Advanced Black Magic

Prentice-Hall, 2003. Practical coverage of high speed digital signals and measurement.

Kimmel and Gerke

Electromagnetic Compatibility in Medical Equipment
IEEE Press, 1995. Good general product design information.

Mardiguian

Controlling Radiated Emissions by Design

Springer, 2016. Good content on product design for compliance.

Mardiguian

EMI Troubleshooting Techniques

McGraw-Hill, 2000. Good coverage of EMI troubleshooting.

Montrose

EMC Made Simple - Printed Circuit Board and System Design

Montrose Compliance Services, 2014. Includes basic theory and product design information

Morrison

Grounding And Shielding - Circuits and Interference

Wiley, 2016 (6th Edition). The classic text on grounding and shielding with up to date content on how RF energy flows through circuit boards.

Morrison

Fast Circuit Boards - Energy Management

Wiley, 2018. A brand new book explaining how electromagnetic energy moves through circuit boards. Destined to be a classic.

Ott

Electromagnetic Compatibility Engineering

Wiley, 2009. The "bible" on EMC measurement, theory, and product design.

Paul

Introduction to Electromagnetic Compatibility

Wiley, 2006 (2nd Edition). The one source to go to for an upper-level course on EMC theory.

Sandler

Power Integrity - Measuring, Optimizing, and Troubleshooting Power Related Parameters in Electronics Systems

McGraw-Hill, 2014. The latest information on measurement and design of power distribution networks and how the network affects stability and EMC.

Smith and Bogatin

Principles of Power Integrity for PDN Design - Simplified

Prentice-Hall, 2017. Getting the power distribution network (PDN) design right is the key to reducing EMI.

Williams

EMC For Product Designers

Newnes, 2017. Completely updated text on product design for EMC compliance.

Weston

Electromagnetic Compatibility - Methods, Analysis, Circuits, and Measurement

CRC Press, 2017 (3rd Edition). A comprehensive text, primarily focused on military EMC.

Wyatt & Jost

Electromagnetic Compatibility (EMC) Pocket Guide

SciTech Publishing, 2013. A handy pocket-sized reference guide to EMC.

REFERENCES

(ARTICLES, STANDARDS, BOOKS, MINI GUIDES, WEBSITES, & LINKEDIN GROUPS)

RECOMMENDED MINI GUIDES FROM INTERFERENCE TECHNOLOGY

2021 Automotive EMC Guide

<https://learn.interferencetechnology.com/2021-automotive-emc-guide/>

2020 EMC Testing Guide

<https://learn.interferencetechnology.com/2020-emc-testing-guide/>

2020 EMC Fundamentals Guide

<https://learn.interferencetechnology.com/2020-emc-fundamentals-guide/>

2020 Military & Aerospace EMC Guide

<https://learn.interferencetechnology.com/2020-military-and-aerospace-emc-guide/>

2020 Medical EMC Guide

<https://learn.interferencetechnology.com/2020-medical-emc-guide/>

2020 IoT, Wireless, 5G EMC Guide

<https://learn.interferencetechnology.com/2020-iot-wireless-5g-emc-guide/>

2020 Europe EMC Guide

<https://learn.interferencetechnology.com/2020-europe-emc-guide/>

2019 EMC Fundamentals Guide

<https://learn.interferencetechnology.com/2019-emc-fundamentals-guide/>

2019 Directory & Design Guide

<https://learn.interferencetechnology.com/2019-directory-and-design-guide/>

2019 Military & Aerospace EMC Guide

<https://learn.interferencetechnology.com/2019-military-and-aerospace-emc-guide/>

2019 Components & Materials Guide

<https://learn.interferencetechnology.com/2019-components-and-materials-guide/>

2019 Europe EMC Guide

<https://learn.interferencetechnology.com/2019-europe-emc-guides/>

RECOMMENDED WEBSITES

Doug Smith

<http://emcesd.com>

EMC Information Centre (Archived)

<http://www.compliance-club.com>

Henry Ott

<http://www.hottconsultants.com>

Interference Technology

<https://interferencetechnology.com>

Keith Armstrong

<https://www.emcstandards.co.uk>

Kenneth Wyatt

<http://www.emc-seminars.com>

Patrick André

<http://andreconsulting.com>

Silent Solutions

<http://www.silent-solutions.com/index.htm>

University of Missouri EMC Lab

<https://emclab.mst.edu>

University of Oklahoma EMC

<http://www.ou.edu/engineering/emc/>

Van Doren Company

<http://www.emc-education.com>

LIST OF LINKEDIN GROUPS

- Aircraft and Spacecraft ESD/EMI/EMC Issues
- Automotive EMC Troubleshooting Experts
- Electromagnetic Compatibility Forum
- Electromagnetics and Spectrum Engineering Group
- EMC - Electromagnetic Compatibility
- EMC Experts
- EMC Troubleshooters
- ESD Experts
- Signal & Power Integrity Community

WHAT IS THE MOST IMPORTANT EMC DESIGN GUIDELINE?

Marcel van Doorn

Freelance EMC Trainer and Consultant
Marcel.van.Doorn@home.nl

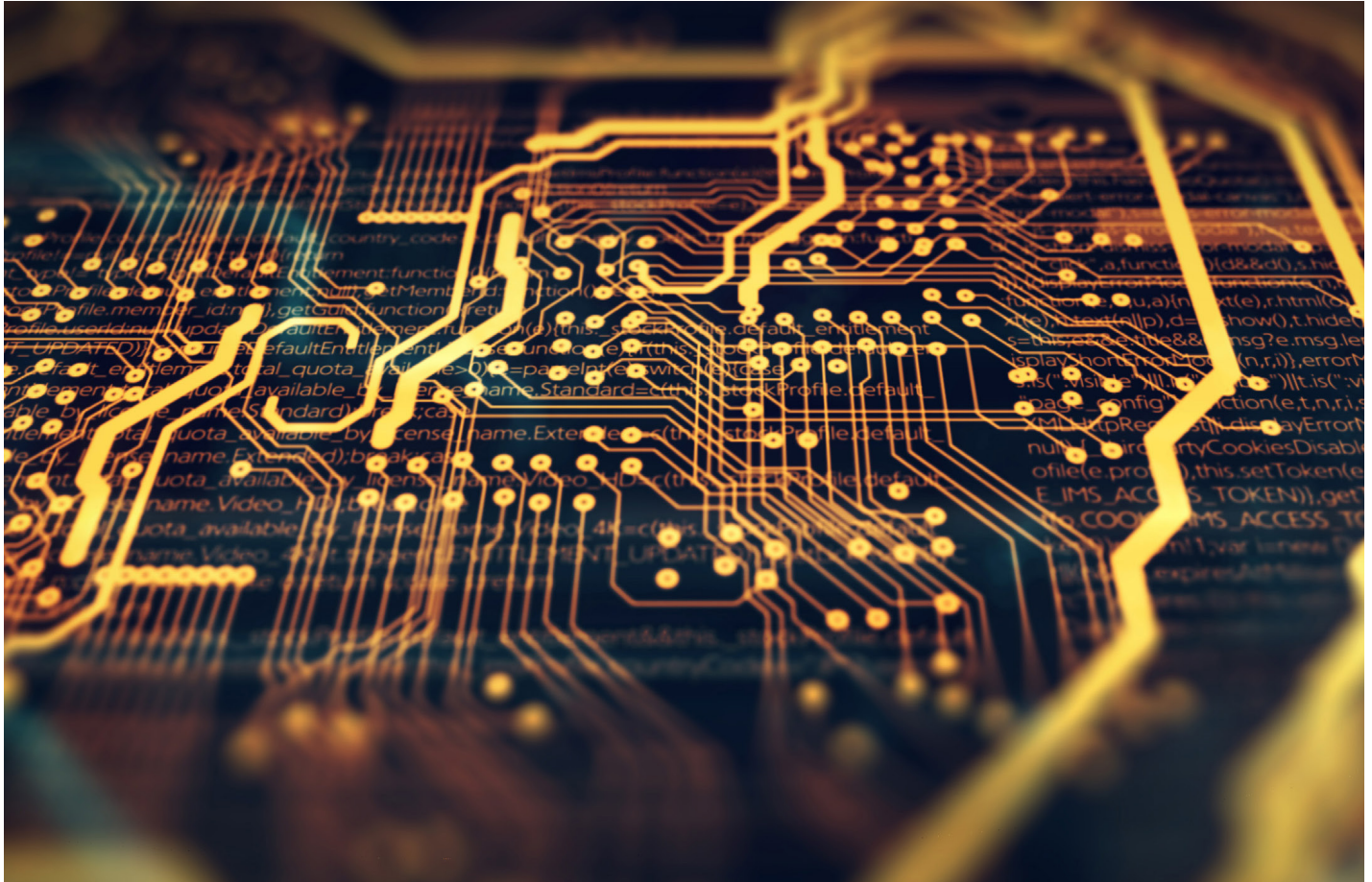

WHAT IS THE MOST IMPORTANT EMC DESIGN GUIDELINE?

INTRODUCTION

EMC design guidelines have always been a popular subject in the EMC design community. What is the most important EMC design guideline, i.e. the guideline with the highest impact on the emission and immunity of electronic circuitry? Studying books and literature from renowned EMC experts often tells us that the most important EMC design guideline is!:

- Minimize loop areas associated with high-frequency (HF) signal currents.

My preferred design guideline is another one. In this article we will show with an experiment demonstration that there is another design parameter that has much more impact on the EMC behavior of an electronic circuit than just the loop area of the signal current. Do you want to know which design parameter this is? Read on.

EXPERIMENT DEMONSTRATION

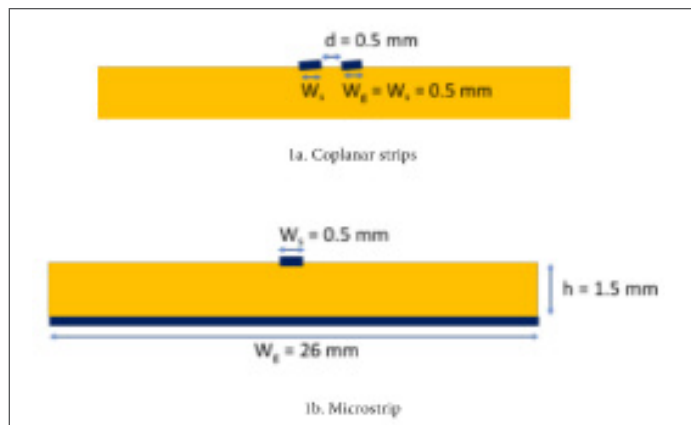

Figure 1. Printed Circuit Board configurations

The experiment demonstration consists of two configurations on a printed circuit board: a coplanar strips line and a microstrip line (Figure 1). Both lines have a length $l = 100$ mm. The coplanar traces have a width $W_{\text{signal}} = W_{\text{ground}} = 0.5$ mm. The distance between the two traces $d = 0.5$ mm. The microstrip has a trace width $W_{\text{signal}} = 0.5$ mm. The width of the ground plane underneath the trace is $W_{\text{ground}} = 26$ mm. The height of the trace above the ground plane is $h = 1.5$ mm. The copper thickness is $35 \mu\text{m}$ and the relative dielectric constant of the FR4 board material is $\epsilon_r = 4.7$.

Figure 2 shows the demo board with the coplanar strips and microstrip lines.

Figure 3 shows the measurement setup. On the demo board both lines are terminated with an SMA 50Ω RF load. The input of the line is connected to the tracking generator output of the Rigol DSA815 spectrum analyzer with an RG223 double braided coaxial cable of 1 m length. The tracking generator output level is $100 \text{ dB}\mu\text{V}$ (100 mV) over the frequency range 30 MHz to 300 MHz . For the frequen-

cies involved the length l of the board traces is small compared to the wavelength ($l \ll 1 \text{ m}$). In both lines flows a differential mode (DM) current $I_{\text{DM}} = 100 \text{ mV}/50 \Omega = 2 \text{ mA}$. With a current monitoring probe from Fischer Custom Communications (F-61) the common-mode (CM) current on the double braided coax cable is measured. The current probe is connected to the input of the spectrum analyzer. By shifting the current probe along the cable with the spectrum analyzer in the max hold mode the maximum CM current is recorded. The results will be discussed in the next section.

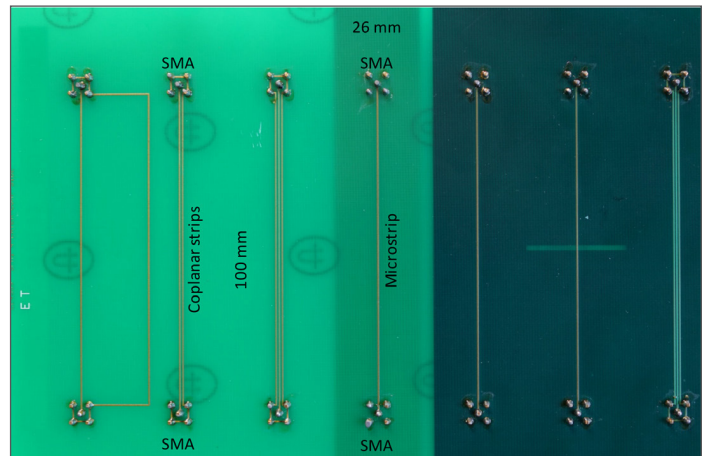

Figure 2. Demo board with coplanar strips and microstrip lines

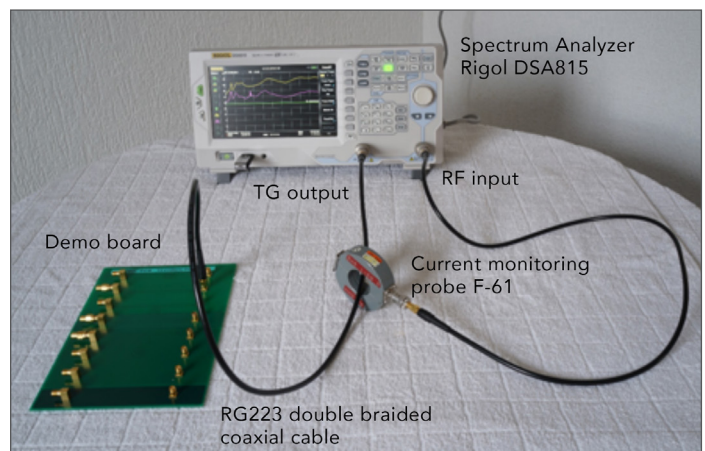

Figure 3. Measurement setup Common-Mode current generated by coplanar strips and microstrip

Now let's have a look to the loop area of the high frequency signal current. For the coplanar strips line, the signal current loop area is approximately (taking the proximity effect into account) $l \times d = 100 \text{ mm} \times 0.5 \text{ mm} = 50 \text{ mm}^2$. The microstrip line has a signal current loop area $l \times h = 100 \text{ mm} \times 1.5 \text{ mm} = 150 \text{ mm}^2$. In our experiment demonstration the current loop area of the microstrip configuration is 3 times (10 dB) larger than that of the coplanar strips configuration.

At high frequencies ($> \text{MHz}$), signal currents take the path of least impedance, this is generally the path of least inductance, which is generally the path that minimizes the loop area. Currents return as close as possible to the path of the outgoing current. In the case of the microstrip most of the return current flows in the ground plane directly underneath the signal trace.

RESULTS AND DISCUSSION

The measurement results of the maximum CM current for the coplanar strips and microstrip configuration are depicted in Figure 4. Over the full frequency range from 30 MHz to 300 MHz the coplanar strips line generates approximately 20 dB higher CM currents than the microstrip line, although its current loop area is 10 dB smaller. The CM current limit line of 10 dB μ A (3 μ A) shown in Figure 4 is based on the far field radiation of a resonant half wave dipole antenna and corresponds roughly with a maximum electric field strength of 30 μ V/m (30 dB μ V/m) at a 10-meter distance from the antenna (legal radiated emission limit). The current probe F-61 has a transfer impedance of 20 Ω in the frequency range 30 MHz to 300 MHz. So, a current of 3 μ A will give at the 50 Ω input of the spectrum analyzer a voltage of 3 μ A \times 20 Ω = 60 μ V = 36 dB μ V.

What is the physics behind this CM current generation? The DM current I_{DM} in the circuit loop on the board induces a CM voltage V_g across the ground return conductor. This CM ground voltage V_g acts as the antenna voltage for the cable connected to the board and generates antenna currents (CM currents) on the shield of the coax cable. The cable is an efficient antenna in the frequency range 30 MHz to 300 MHz and in the graphs in Figure 4 the cable resonances are clearly visible. The radiated emission is proportional to the antenna current (CM current).

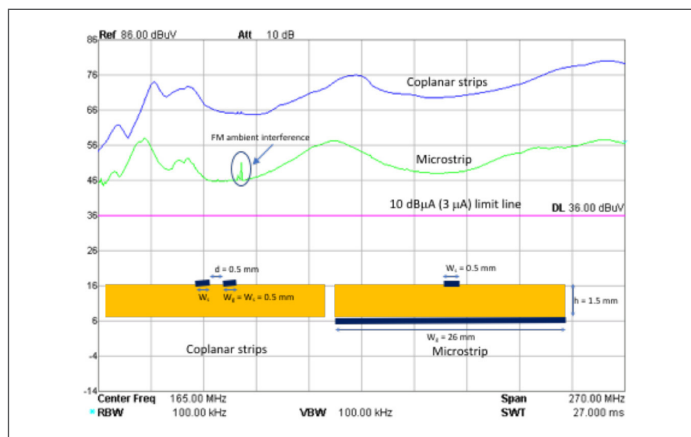

Figure 4. Measurement results common-mode current coplanar strips versus microstrip

The CM ground voltage is determined by the partial inductance of the ground return lead: $V_{CM} = I_{DM} 2\pi f L_g$.

As a first order approximation for the partial inductance of a microstrip ground plane we can use the formula²:

$$L_g \approx (\mu_0 h) / (2W_g) \text{ if } W_g \gg h \quad \text{permeability } \mu_0 = 4\pi 10^{-7} \text{ (H/m)}.$$

The ground plane inductance L_g (Henry/m) is proportional with the trace height h (m) above the plane and inversely proportional with the ground plane width W_g (m).

For our microstrip configuration ($h = 1.5$ mm, $W_g = 26$ mm) the resulting ground plane inductance is:

$$L_{g \text{ microstrip}} = 36 \text{ nH/m}.$$

For our coplanar strips configuration ($d = 0.5$ mm, $W_g = 0.5$ mm) the inductance of the ground return trace is approximately:

$$L_{g \text{ coplanar trace}} = 300 \text{ nH/m, i.e. an 18 dB higher inductance than that of the microstrip ground plane.}$$

This difference of approximately 18 dB in ground return inductance is reflected in the CM current (radiated emission) plots of the coplanar strips and microstrip in Figure 4. The lower the ground return inductance the lower the radiated emission. In³ the theory of partial inductance to control emissions is explained very clearly.

CONCLUDING REMARKS

From the experiment we learn that although the differential mode current loop area of the microstrip line is much larger (10 dB) than that of the coplanar strips line the radiated emission of the microstrip line is much lower (20 dB) in the frequency range 30 MHz to 300 MHz. The main reason for this behavior is the partial inductance of the ground return lead. The ground plane of the microstrip has a much lower inductance than the ground trace of the coplanar strips, which results in a much lower common-mode ground voltage for the microstrip line and consequently a much lower radiated emission. The design parameter that has the highest impact on the EMC performance of an electronic circuit is not just the signal loop area but the partial inductance of the ground return conductor.

We may conclude that the most important EMC design guideline is:

- Minimize the inductance of the ground return conductor.

On a printed circuit board this can be realized by making the ground return conductor shorter, placing the signal trace closer to the ground plane AND by making the ground return plane wider. This is also valid for flex foil cables. The ultimate example of an extremely low ground return inductance (low transfer impedance) is an HF coax cable with a semi-rigid coaxial shield. This solid shield results in hardly any field leakage, assuming perfect connectors.

Do you have a different opinion? Let's start a discussion! Contact Marcel at: marcel.van.doorn@home.nl

REFERENCES

- [1] <https://learnemc.com/the-most-important-emc-design-guidelines>
- [2] F.B. J. Leferink, M.J.C.M. van Doorn, "Inductance of Printed Circuit Board Ground Planes", IEEE International Symposium on Electromagnetic Compatibility, Dallas 1993.
- [3] Glen Dash, "Know the Theory of Partial Inductance to Control Emissions", IN Compliance, 2010 Annual Guide, www.incompliancemag.com

ASSEMBLING A LOW COST EMI TROUBLESHOOTING KIT

Part 1: Radiated Emissions

Part 2: Miscellaneous Additions & Immunity

Kenneth Wyatt

Wyatt Technical Services LLC

ken@emc-seminars.com

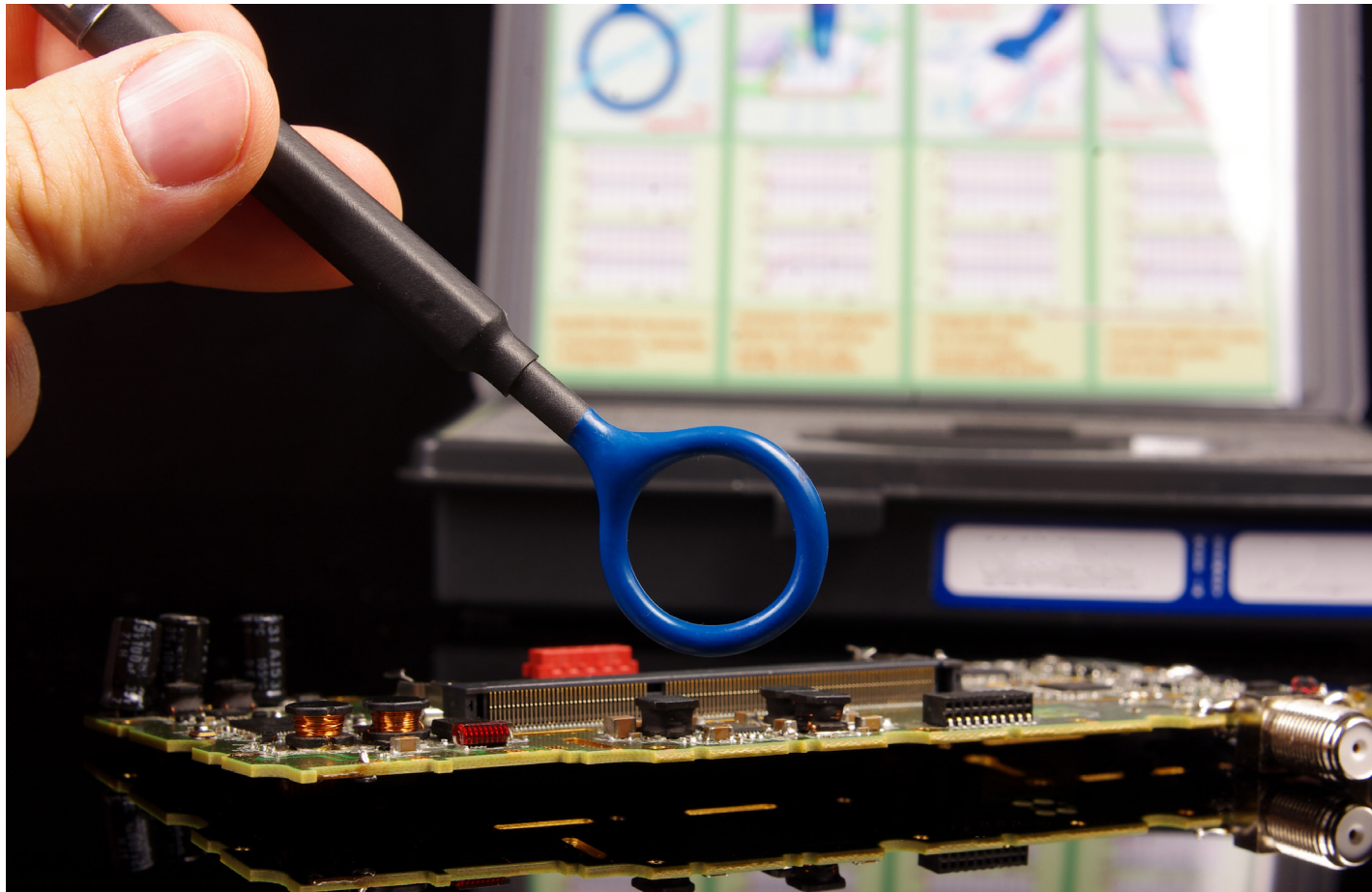

PART 1: RADIATED EMISSIONS

Those of us who are either in-house or independent EMC consultants can benefit greatly by assembling our own EMI troubleshooting kit. I've depended on my own kit for several years and it has proven not only valuable, but depicts a sense of professionalism in dealing with your own product development engineers, their managers, or your clients, as the case may be. Mine is designed around a Pelican 1514 roller case (<http://www.pelican.com>) that includes a padded divider, so it is easy to transport to the area needed. You'll also want to order the optional lid organizer, model 1519, for carrying extra tools, cables, and other small parts. See *Figure 1*.

This article will summarize what I've included in my own kit, and because everyone's needs might be a little different, you'll want to use this information as a guide. Feel free to add or subtract tools and test equipment as desired. You should expect to spend about \$3k to \$5k for the complete kit, depending on whether you make a lot of DIY probes or buy commercial, but this price range includes a spectrum analyzer.



Figure 1 - Troubleshooting kit with most of the major components shown. The spectrum analyzer is the Thurlby Thandar model PSA6005 and tunes from 10 MHz to 6 GHz. Everything fits inside a Pelican 1514 roller transit case. The contents are described in Part 1 and Part 2 of this article

I'll list just the most important items for assessing radiated emissions in Part 1. Part 2, at the end of this article, will include additional items required for assessing various immunity tests, along with many other useful tools and equipment. Some of this information is based on the book, *EMI Troubleshooting Cookbook for Product Designers*[1], by Patrick André and Kenneth Wyatt, with foreword by Henry Ott.

SPECTRUM ANALYZERS

You're probably wondering about the spectrum analyzer, so we'll start with that first. The spectrum analyzer is the one piece of gear that's essential for EMI troubleshooting, but has traditionally been the most expensive item in anyone's

kit. Many smaller or mid-sized companies may not have the budget to purchase a lab quality analyzer, which can start at a base price of \$10k, or more. While you may find older used spectrum analyzers on sites, such as eBay or from used equipment dealers, several manufacturers are now making lower cost quality instruments that are perfectly adequate for troubleshooting and pre-compliance work. I've listed several instruments from which to choose – in categories, good, better, and best.

GOOD – I've run into a very low cost spectrum analyzer solution; the Triarchy Technologies (<http://triarchytech.com>) USB-controlled spectrum analyzer, which is about the size of a large thumb drive (*Figure 2*). Triarchy makes several models covering up to 12 GHz, but their Model TSA6G1 covers most of the commercial frequency range of 1 MHz to 6.15 GHz, can measure signals from -110 to +30 dBm, and costs just \$629 through their eBay store or through their North American distributor, Saelig Electronics (<http://www.saelig.com>). The unit comes with Windows PC software and works perfectly well for troubleshooting. I wouldn't necessarily use it for pre-compliance testing, but it should still provide a good enough indication as to whether you're in the ballpark of passing or failing.

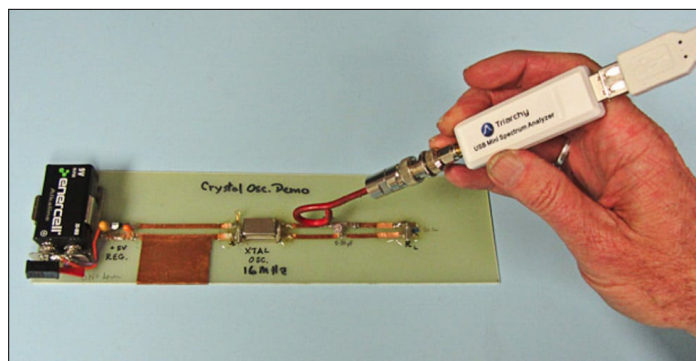

Figure 2 - Here's an example of a low cost USB powered spectrum analyzer. This one is made by Triarchy Technologies and is sensitive enough for general EMI troubleshooting. The model TSA6G1 tunes from 1 MHz to 6.15 GHz.

BETTER - You may want to consider a better quality analyzer. I've been using the Thurlby Thander (TTI) PSA2702T (1 MHz to 2.7 GHz handheld, at \$1695) for several years now (*Figure 3*) and recently upgraded to the model PSA6005. TTI is a British company (<http://www.aimtti.com> in the UK and <http://www.aimtti.us> in the U.S.), well known for their lines of test and measurement equipment. Newark (<http://www.newark.com>) and Saelig Electronics (<http://www.saelig.com>) are the North American distributors. Many other independent consultants are also using this one. It's truly handheld and will easily fit into the recommended transit case. TTI also sells a similar handheld model PSA6005 that tunes from 10 MHz to 6 GHz and costs about \$2,700.

These analyzers offer most of the usual settings for resolution bandwidth, frequency setting, saving/recall of instrument setups, different detectors, averaging, and max hold. The controls are all laid out at the bottom of the screen in a hierarchical fashion top to bottom. They also include two



Figure 3 - The Thurlyby Thandar PSA2702T is an affordable portable spectrum analyzer that covers 1 MHz to 2.7 GHz. The cost is just \$1,695 from Saelig or Newark Electronics (Photo, courtesy Thurlyby Thandar Instruments).



Figure 4 - The Rigol DSA815 is an affordable spectrum analyzer that covers 9 kHz to 1.5 GHz. The base cost is just \$1,295. Rigol also has models in the series that cover up to 7.5 GHz. (Photo, courtesy Rigol Electronics).



Figure 5 - The new Siglent SSA3000X-series spectrum analyzer tunes from 9 kHz to 2.1 GHz or 3.2 GHz, depending on the model.



Figure 6 - The Rohde & Schwarz FPH "Spectrum Rider" portable spectrum analyzer tunes from 5 kHz to 2 GHz or an optional upper limit of 3 or 4 GHz as budgets allow. The specifications are very similar to much higher-priced lab quality analyzers and the base price is just \$5,280.

cursors, which can read out both frequency and amplitude simultaneously. There is also USB connectivity for control by free PC software. Battery life is very good at four to six hours. I can plug in a near field probe directly to the RF input and use the entire unit to quickly evaluate a large system for EMI issues.

BEST – There are several affordable choices of quality bench top analyzers. My two favorites include the Rigol DSA815 (Figure 4) and Siglent SSA3000X-series (Figure 5). Rigol Electronics, a test & measurement company based in China (<http://www.rigolna.com>), offers their \$1,295 Model DSA815TG (9 kHz to 1.5 GHz) spectrum analyzer with optional tracking generator (\$200). The extra EMI option (\$599) will give you the three EMI resolution bandwidths (200 Hz, 120 kHz and 1 MHz) and quasi-peak detector. The front panel is nicely laid out and easy to use. Screen captures may be made for documentation purposes and software is available to control the analyzer from your Windows PC. The unit includes all the usual features of a more expensive lab-grade analyzer, but is accurate enough for all your pre-compliance and troubleshooting needs. Besides the usual controls, you can display up to three traces and six markers. The tracking generator allows you to evaluate filters, antennas, and resonances.

Another recent offering from Siglent Technologies (<http://www.siglent.com>),

also based in China, is their SSA3000X-series of low-cost spectrum analyzers. It uses the same compact form factor as the Rigol, but is a little wider to accommodate the wider video display. The base unit tunes from 9 kHz to 2.1 GHz, with another model going to 3.2 GHz. There is a similar EMI and tracking generator option. The control layout is similar to the Rigol and easy to use. Both models offer slightly improved specifications in amplitude accuracy and frequency resolution. The free Windows PC software will also help define limit lines and perform automated pre-compliance testing and documentation.

Finally, there's a third option to consider that's very affordable, considering it has similar specifications as lab quality analyzers. Rohde & Schwarz (https://www.rohde-schwarz.com/us/home_48230.html) recently announced their FPH "Spectrum Rider" portable analyzer, whose base price starts at \$5,280 (Figure 6). I also recommend you purchase the built-in preamplifier option for \$440. I had a chance to review this and was pleasantly surprised. The unit has much of the functionality as much pricier analyzers, but is a compact battery-operated portable. It will exceed my price total budget for the total troubleshooting kit, though!

The instrument controls are all laid out clearly and I really didn't need the user guide to start using it. The unit tunes from 5 kHz to 2 GHz, with 3 or 4 GHz as options. While

there's no tracking generator option, the unit does have a lot to offer as far as accuracy and useful features. The battery life is rated at eight hours and the unit is moisture proof with an easy to read display, even in full sunlight. Perfect for field use!

Any of these analyzers should do well for you, but my preference (if traveling light) remains the TTI PSA2702T because it's fast to use and fits so well into the transit case, avoiding my carrying a second piece of gear. The advantage of the Rigol or Siglent analyzers is that they are more accurate than the TTI PSA2702T and include a preamp, tracking generator, the EMI bandwidths and quasi-peak detector. However, for the base price, they're limited to just 1.5 or 2.2 GHz respectively. The tracking generators are a valuable troubleshooting tool for determining resonances and filter responses. Of course, both Rigol and Siglent have models that go higher in frequency (7.5 and 3.2 GHz, respectively) for additional cost. The Rohde & Schwarz analyzer has even better specifications and is battery-powered, but has no means to add a tracking generator.

REAL TIME SPECTRUM ANALYZERS

If your products include wireless or fast serial data streams, you might wish to consider one of these affordable real-time spectrum analyzers. A real-time spectrum analyzer has the ability to capture brief intermittent signals and are perfect for capturing modulated wireless or digital signals, as well as general EMI troubleshooting. Low-cost examples might include the Tektronix (<http://www.tek.com>) RSA306 (*Figure 7*) or Signal Hound (<http://signalhound.com>) BB60C (*Figure 8*). Both include feature-rich PC software. Either model should fit nicely into the transit case, as both are relatively small.



Figure 7 - The Tektronix RSA306 USB-controlled real-time spectrum analyzer covers 9 kHz to 6.2 GHz and has a real-time bandwidth of 40 MHz. The base cost is \$3,489 and there are several digital modulation display options.



Figure 8 - The Signal Hound BB60C USB-controlled real-time spectrum analyzer covers 9 kHz to 6 GHz and has a real-time bandwidth of 27 MHz. The cost is \$2,879.

For a more detailed review of these two analyzers, as well as several other lab-quality models, be sure to download the new 2016 Real-Time Spectrum Analyzer Mini Guide[2] from *Interference Technology*.

Real-time analyzers can detect and capture very short intermittent pulsed signals. For example, within the 2.4 GHz ISM band, you'll see the entire spread spectrum Wi-Fi signal, as well as the frequency-hopped Bluetooth signals very clearly. You can even observe multiple Wi-Fi access points on the same channel. This isn't possible with normal swept-frequency spectrum analyzers. They also commonly include "waterfall" displays of frequency and amplitude versus time – a very powerful troubleshooting tool for intermittent EMI issues.

TROUBLESHOOTING WITH SPECTRUM ANALYZERS

Typically, we'll use E-field and H-field probes, clamp-on current probes, or voltage probes with spectrum analyzers. These are described more fully later.

For troubleshooting purposes, it's also possible to use standard oscilloscope probes with spectrum analyzers. Just make sure any scope probe or E-field probe is capacitively coupled in the signal line (or use a capacitive isolation adapter or DC block at the analyzer input), so that large DC voltages won't be introduced at the analyzer's sensitive input. That's a good way to damage the front-end circuitry. Don't put much faith in the absolute measurement, as a 10:1 probe connected to a 50-Ohm spectrum analyzer input won't likely be very accurate. However, you can still measure relative improvements as the troubleshooting process progresses. Rigol Electronics has an application note on how to use an oscilloscope probe with a spectrum analyzer[3].

NEAR-FIELD PROBES

Near-field probes, or "sniffer" probes, are small electric or magnetic field pickup devices used to determine the source of emissions generated by a circuit or component (*Figure 9*). The E-field probe is essentially a stub antenna at the end of a coaxial line. An E-field probe can be made by cutting away about 1/4-inch of the outer shield, exposing the center conductor. Insulate the end, so it won't short to anything. The H-field probe is generally a small loop of coaxial cable made by connecting the center conductor to the outer shield. The size of the stub or loop determines the sensitivity of the probe but can also limit its upper frequency range and its ability to localize the source. These near-field probes are easy to make yourself from regular or semi-rigid coax cables.

Near-field probes can be either very useful or very misleading. Larger probes, which are more sensitive, can pick up ambient readings from high-powered broadcast radio and TV. One way to determine an individual probe's sensitivity to ambient signals is to measure the frequency range of 88 to 108 MHz in the FM broadcast radio band. If your favorite station shows up on the oscilloscope or spectrum analyzer, you need to be careful to ignore ambient signals. To do this,

move the probe away from the unit and power down the unit if possible. If the signal does not go away, you should ignore that particular frequency as an ambient.

H-field probes couple best when oriented in the same plane as the wire, cable, or circuit trace because this allows the most H-field lines of flux to penetrate through the loop (Figure 10). The larger loop probes will be the most sensitive, but not as high a spatial resolution as the smaller loop probes. The smallest probes can trace RF noise currents to a single trace or integrated circuit pin.

Most H-field loop probes are shielded for E-fields, but the capacitance between the shielding and circuit being measured adds a parasitic capacitance that can cause a high-frequency resonance (about 700 to 1,000 MHz, depending on the probe design). By constructing an unshielded loop you can avoid this resonance, but then you also sacrifice rejection of E-fields.

Because most circuit traces are low impedance, and are therefore relatively high current structures, H-fields tend to dominate in digital products. We tend to use H-field probes to locate "hot" signal sources on cables or circuit traces (Figure 11). By carefully sweeping the probe around on the circuit board and interior cables, areas of high emissions can be located. On the other hand, E-field probes are most useful for detecting leakage in chassis seams or gaps, where there might be high levels of E-fields.

You need to be careful when mapping out "hot spots" of RF energy. Just because you measure a high field level in a certain part of the circuit board or cable, does not necessarily mean that energy will be coupled out and radiate. It all depends on whether there is a coupling path from the RF energy source to some "antenna-like" structure, such as an I/O or power cable. Generally, near field probes are good for identifying potential emission sources, but I rely on nearby antennas to troubleshoot actual emissions from a product.

If you prefer low cost commercial probes, I can recommend the set from Beehive Electronics (<http://beehive-electronics.com>) or Tekbox Digital Solutions (<http://www.tekbox.net>). The Beehive probe set is \$300 and you'll also want to include the 1m long SMB to SMA cable for \$50 (Figure 12). Tekbox sells a set of four probes with cable for \$200 and the probe set with broadband preamplifier for \$330. Saelig Electronics (<http://www.saelig.com>) is the North American distributor for Tekbox. The Beehive probes may be ordered directly from Beehive Electronics.

CURRENT PROBES

Clamping a current probe around a wire or cable will measure the common-mode RF currents flowing in that wire or cable. They typically use a toroidal core of broadband ferrite or similar material. The frequency range and sensitivity of the probe will depend on the type of material used and the number of turns of wire wound around the core as a

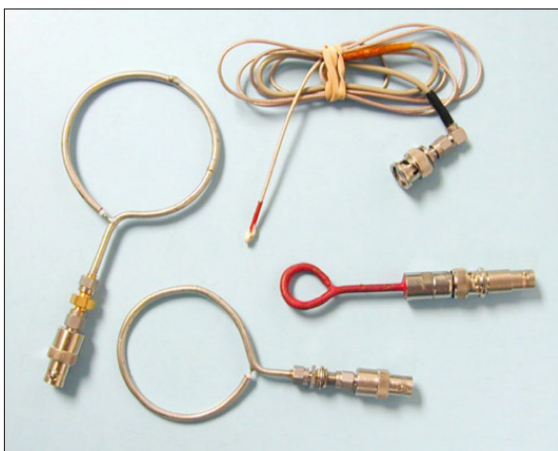

Figure 9 - A few E-field and H-field probes made from short pieces of semi-rigid or flexible coax cables.

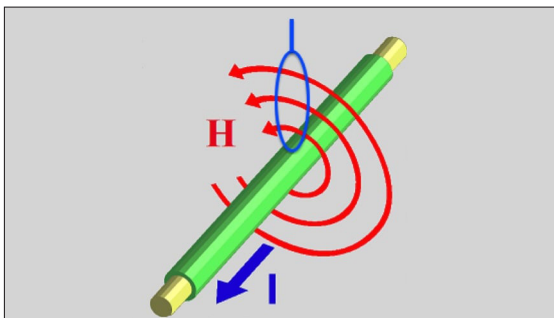

Figure 10 - Proper positioning of an H-field probe for maximum coupling.

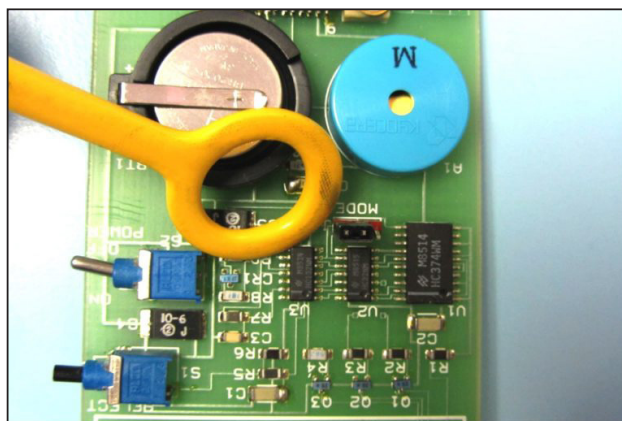

Figure 11 - Using an H-field probe to locate hot spots on a circuit board. For higher resolution measurements, smaller probes should be used.



Figure 12 - A typical near-field probe set. In this picture, there are three H-field loop probes and one E-field probe. (Courtesy, Beehive Electronics.)

pickup. On emission-only probes, a resistive network is often used to control the impedance and flatten the response. This response is known as the correction, transfer impedance, or transducer factor. Similar current probes can be used to inject RF energy into a cable and are called bulk current injection (BCI) probes. They are used for conducted RF immunity tests.

Current probes are very useful as a troubleshooting tool. Measuring current on certain cables can indicate which cables may be the main cause of radiated emissions. The reduction of RF currents on those cables can often reduce the radiated emissions from the equipment under test. Importantly, by knowing the harmonic common-mode current flowing in the cable at a certain frequency you can calculate the expected E-field emission level and compare to the radiated emission limit. In other words, you can predict pass/fail for a particular cable by simply measuring the RF current through that cable. Refer to the article below for details.

It's possible to make your own current probes from ferrite toroids or clamp-on chokes (*Figure 13*). I published an earlier article, *The HF Current Probe: Theory and Application*, on making and using current probes for Interference Technology in the 2012 EMC Directory and Design Guide[4] and would refer you to that resource for more detail.

The advantage of commercial current probes is that they easily clamp around the wire or cable to be evaluated and they are calibrated to accurately read RF current. While

the Fischer model F-33-1 probes (<http://fischercc.com>) are used as an example (see *Figure 14*), there are many other good manufacturers of current probes, such as Pearson, Rohde & Schwarz, Teseq, Solar, and ETS-Lindgren.

ANTENNAS

EMI antennas can be very expensive, so I recommend smaller, low-cost antennas, such as the rabbit ears TV antenna still available in some TV and electronic parts stores (*Figure 15*). UHF TV "bowtie" antennas also work well from 300 to 800 MHz. They will perform just fine for troubleshooting purposes.

Remember, EMC troubleshooting relies more on relative changes, rather than absolute changes. For example, if you know your product is failing by 4 dB, reducing the problem harmonic by 10 dB at your own facility, as measured with a nearby antenna, should provide a reasonable assurance of passing.

Also available are low-cost (under \$30) PC board broadband log-periodic antennas from Kent Electronics (www.wa5vjb.com) in *Figure 16*. These are designed for several frequency bands, starting at 400 MHz and have about a 6 dB gain across the band. They work well for general troubleshooting and are what I currently use. Being flat, they fit easily into the transit case.

I mount mine using a small tabletop photo tripod and a DIY fixture made from PVC pipe (*Figure 17*). I tapped and thread-



Figure 13 – An example of simple current probes you can make to measure harmonic RF currents in cables.



Figure 14 – A matched set of clamp-on Fischer Custom Communications model F-33-1 current probes. While not imperative to purchase, a matched set is very useful for advanced troubleshooting I/O cable emissions. They can sense RF currents of a few microamps.



Figure 15 – Simple rabbit ears TV antennas may be used to pick up radiated emissions from a product under test. It will tune from 85 to about 220 MHz depending on how long the elements are extended. Epoxy a BNC connector to the housing and connect each terminal to the telescoping elements.

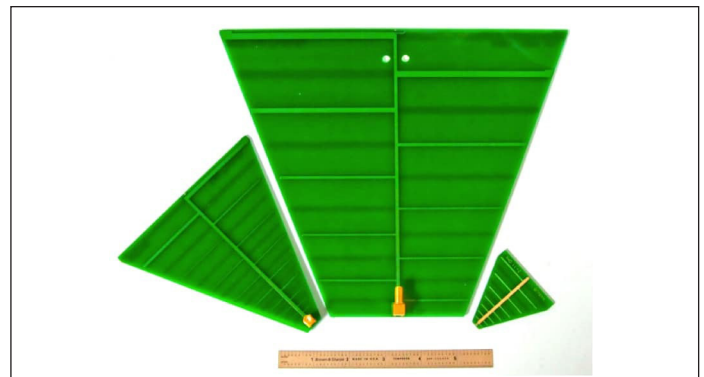

Figure 16 – These PC board log-periodic antennas are low in cost and are resonant in several bands from 400 MHz to 11 GHz. They are available from <http://www.wa5vjb.com>.

ed the 90-degree coupling to fit the tripod and used a hand-saw to cut a narrow slit in the other end. The PC board just presses into the slot. I left the horizontal piece unglued, so I can rotate the antenna for horizontal or vertical polarization.

For a little more cost, I also like the small active broadband antenna from Aaronia AG (*Figure 18*). Their model BicoLOG 30100X covers 30 to 1000 MHz and includes a battery-operated broadband preamplifier. The cost is just \$1,299 and may be ordered directly from Aaronia AG in Germany (<http://www.aaronia.com/products/antennas/BicoLOG-30100-X/>) or their North American distributors, Kaltman Creations (<http://kaltmancreationsllc.com>) or Saelig Electronics (<http://www.saelig.com>). Aaronia also has compact antennas that tune from 700 MHz to 6 GHz.

Whether an antenna is resonant at the frequency harmonic of concern is not that important. So long as you can observe the RF harmonics at a distance of 1m, or more, the troubleshooting process can start. *Figure 19* shows my typical setup for evaluating and troubleshooting radiated emissions. By monitoring the spectrum analyzer as you try various fixes, you can see immediately whether progress has been made. The best part is that you can do this testing right at your lab bench.

FERRITE CORES AND CHOKES

RF currents on cables (and associated radiated emissions) may usually – but not always – be reduced by clamping a ferrite choke around the I/O or power cable nearest the source of RF noise. Adding a few of these chokes in various sizes to your kit would be helpful for troubleshooting (*Figure 20*). It's sometimes best to use a large (2.4 inch) toroid ferrite core of 31, or similar, material with multiple turns through it for use in frequencies below 30 MHz. This is a common cure for interference to (or from) consumer equipment. Most common beads and clamp-on ferrites are generally more effective at frequencies in the 100s of MHz, unless the ferrite material is specifically designed for lower frequencies.

MISCELLANEOUS

Adhesive copper tape is also useful for sealing enclosure joints temporarily during troubleshooting. Rolls of this tape may be purchased from electronics distributors at \$30, or more, per roll. I've also found that "snail tape" (under \$10) used in gardening may be substituted. This may be found in garden stores or on Amazon. Take care not to cut yourself on the sharp edges.

Aluminum foil is also handy as a troubleshooting tool for wrapping around an interfering product to assess whether additional shielding might help. Note that aluminum foil is not as effective at power line frequencies.

Finally, a selection of capacitors, resistors, inductors, and common-mode chokes is useful for applying filtering to I/O, microphone, and power line cables.

REFERENCES

- [1] EMI Troubleshooting Cookbook for Product Designers is available from Amazon and Stylus Publishing in the U.S., and from The IET in Europe. Go to <http://www.emc-seminars.com> or <http://www.andreconsulting.com> for specific links.
- [2] Download the 2016 Real-Time Spectrum Analyzer Mini Guide, from Interference Technology here: <http://itemmedia.wufoo.com/forms/p17royzx0h132fe/>.
- [3] How To Use A Probe with a Spectrum Analyzer: <http://www.rigolna.com/products/spectrum-analyzers/dsa800/dsa815/>
- [4] The HF Current Probe: Theory and Application: <https://interferencetechnology.com/the-hf-current-probe-theory-and-application/>.

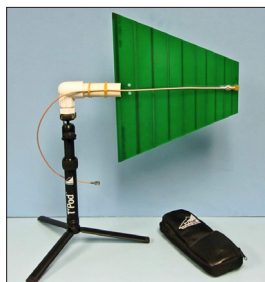

Figure 17 - One of the PC board log-periodic antennas mounted to a tabletop camera tripod. By setting this up near the product under test, the emissions may be observed during troubleshooting.



Figure 18 - A small broadband active antenna from Aaronia that is very useful for bench top troubleshooting of radiated emissions.



Figure 20 - Examples of various clamp-on ferrite chokes.

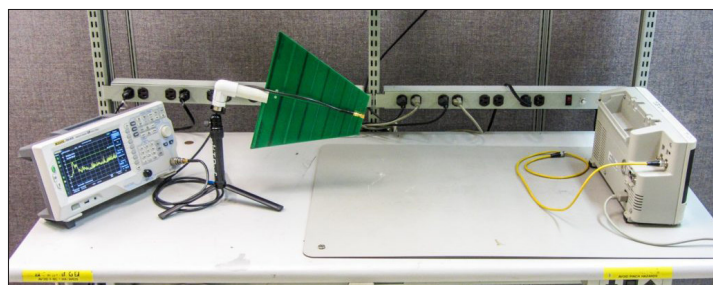

Figure 19 - The typical setup used to troubleshoot radiated emissions. Position the antenna and spectrum analyzer about 1m away from the product under test so you can observe progress in real time.

PART 2: MISCELLANEOUS ADDITIONS AND IMMUNITY

USEFUL ADDITIONS TO YOUR KIT

Sometimes the signal level from near field probes needs a boost – especially from the smaller-diameter H-field probes. For this, I recommend a broadband preamplifier, such as those available from Mini-Circuits (*Figure 1*), Beehive Electronics, Tekbox, or Aaronia AG. There are many other manufacturers of these from the larger test and measurement companies.

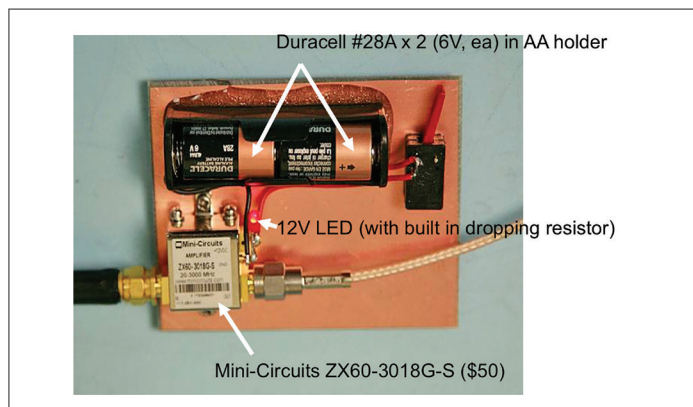

Figure 1. The Mini-Circuits model ZX60-3018G-S broadband 20 - 3,000 MHz pre-amplifier mounted on a PC board has a 20 dB gain and 2.4 dB noise figure. It's powered by two 6 V batteries mounted in a single AA holder. The price is about \$50 through their web site (<http://www.minicircuits.com>).

Beehive Electronics also has a nice preamplifier that can be powered from an exterior 9V battery plugged into the power input jack (*Figure 2*). This makes the unit portable with one less line cord to deal with. The unit has 30 dB of gain from 100 kHz to 6 GHz, which covers all the commercial frequency ranges of interest. The cost is \$525 through their web site (<http://www.beehive-electronics.com>).

β

Metal knitting needles may be used as antennas by touching to the circuit board or pins of a connector. Being metal, they will act as an extended antenna. If the circuit connector pin is a source of RF, this may increase when touched with the metal knitting needles. Be sure to insulate the handle end of needle for safety reasons and take care to avoid shorting out circuits.



Figure 2. Beehive Electronics makes a \$525 30 dB gain broadband preamp that is useful from 100 kHz to 6 GHz.

Plastic knitting needles, crochet hooks, or probes may be used to manipulate wires or press on chassis without having to touch the equipment, which can change its effective radiation (*Figure 3*).



Figure 3. Metal and plastic knitting needles may be used to test for RF energy on connector pins. Plastic crochet hooks can manipulate cables without having to touch them.

USEFUL RADIATED IMMUNITY ITEMS

One of the more frequent product failures I see is radiated immunity. That is, the product under test is susceptible to outside RF transmitters. There are a number of low cost solutions to help check the sensitivity of your product to external RF energy.

One of the simplest is a small handheld Family Radio Service (FRS) license-free walkie-talkie (*Figure 4*). These produce about 1/2-watt in the 465 MHz band and may be used to quickly check the susceptibility to RF, in general. Best of all, they sell for about \$30 a pair. Just press the transmit button briefly and hold it near your product to see if it induces any upset or instrument lockup. I've resolved many radiated immunity problems with nothing more than one of these radios.



Figure 4. A typical 0.5W 465 MHz Family Radio Service two-way radio. Some other countries have similar license-free radios that may be used for simple radiated immunity testing.

For a more elegant and controlled test, I find the PC-controlled RF synthesizer; model SynthNV, from Windfreak Technologies to be ideal (*Figure 5*). It will produce up to +19 dBm (90 mW) into 50 Ohms. The unit tunes from 34 MHz to 4.4 GHz in user-defined steps as low as 1 kHz. It can also modulate the RF with AM or pulse modulation, which is useful for commercial or military immunity testing according to the respective standards. The price is \$599 from their web site (<https://windfreaktech.com>).

To perform a quick immunity test with the SynthNV, simply



Figure 5 - The Windfreak Technologies RF synthesizer is small and can produce up to +19 dBm from 34 MHz to 4.4 GHz. It can also modulate the RF with AM or pulse.

attach the larger size H-field probe to the output and scan the probe around on your circuit board and any interconnecting or I/O cables. Adjust the frequency to step every 50 MHz, or so, for each scan throughout the desired frequency band. For more details, refer to the article, *Inexpensive Radiated Immunity Pre-Compliance Testing*^[1].

Another very effective source of broadband RF emissions is a “chattering relay”. This is actually specified in certain MIL-STD-461 and DO-160 standards. A chattering relay is merely a line or DC-operated relay with the normally closed contacts wired through the coil. When powered, the relay coil opens the contacts, which then deactivate the coil, allowing the contacts to close again. This continues with a loud buzzing sound as the contacts continuously open and close. The inductance of the coil creates a 600 to 800 volt repeated arcing across the contacts. This produces a broadband RF noise spectrum as high as 1 GHz. According to the standards, closely coupling the cable of the chattering relay to the product’s power cable, is a rather rigorous immunity test. I find that simply holding the relay near your product circuitry should reveal any issues pretty quickly.

TESTING FOR ELECTROSTATIC DISCHARGE (ESD)

The other frequently encountered EMC issue I find is due to susceptibility to ESD. With the trend towards lower power supply voltages (5V to 3.3V to 1.8V to 1.2V, and lower) is the overall reduction in noise margin for digital circuits. There are a number of low cost tools we can use to evaluate our products for ESD immunity.

Normally, ESD current pulses of up to 8 or 15 kV are applied to any external metal that could be touched by the equipment operator. This would include front panel controls, displays, connector ground shells, metal enclosures, and the like. Exceptions under most ESD standards would preclude testing directly into I/O pins or internal circuitry. I must caution you that this test is potentially destructive, so I usually try to test less sensitive points first and with lower test voltages.

Of course, the best approach would be to use a commercial ESD simulator. I like the KeyTek MiniZap (*Figure 6*). While new ones can cost about \$20k, these may be commonly found in the used market for under \$3,000. However, to fit within our \$5,000 maximum budget, here are some alternatives that will help characterize the ESD immunity of your product.



Figure 6 - The Keytek Mini-Zap is a handy handheld ESD simulator that can test up to 15 kV. The contact discharge tip is shown.

There are various piezoelectric spark sources, such as BBQ lighters, that will produce several kV of electricity. One I like is the Coleman brand butane lighter, because you don’t need to open the gas valve in order to trigger a spark (*Figure 7*). By carefully removing part of the outer metal shroud with a Dremel tool, you’ll expose the center tip where the arcs originate. Connecting a ground return wire to the metal shroud will complete the circuit. Just place the product under test on a metal-top table (or lay out some aluminum foil to cover the table top as a conductive plane). You’ll need a way for the electrostatic charges to bleed off the metal plane, and you can connect a 1 Megohm resistor from the metal plane to earth. Then, connect the ground return wire to the metal plane, hold the lighter tip within 1/4-inch and start triggering the arcs. This lighter will produce from 4 to 6 kV discharges.



Figure 7 - The Coleman brand lighter is unique that the butane has a separate control switch with no need to empty the reservoir. Cut the metal shroud back with a Dremel tool to expose the tip and connect a length of grounding wire. It produces about 4 to 6 kV from the piezoelectric element when the trigger is pulled.

The problem with ESD susceptibility is that it usually occurs

infrequently. Therefore, you'll also want a way to detect ESD discharges to help indicate when an event occurred. An inexpensive AM broadcast receiver (*Figure 8*) will make a simple ESD detector. Just tune the radio off-station, so you just hear the background hissing. You'll be able to hear ESD events as "clicks" in the static.



Figure 8 - An AM broadcast band radio tuned off-station is useful for detecting the "clicks" of ESD events.

If you're handy with electronic projects, you can also make the DIY ESD detector and counter found on my personal web site. It is based on a popular lightning detector circuit. The construction article may be found under "Technical Articles" at <http://www.emc-seminars.com>. The basic circuit includes the detector and a pulse-stretcher circuit. By adding extra switch transistors, you can add various indicators. Mine will blink a light, beep a buzzer, and also has a digital event counter.

A better commercial tool would include the "ESD Pro" ESD detector (*Figure 9*), manufactured and sold by Static Control Systems (<http://staticcontrol.descoindustries.com>). It is extremely sensitive and will detect ESD from hundreds of feet away.



Figure 9 - A typical commercial ESD detector. This one is the model "ESD Pro" from Static Control Systems (Courtesy Static Control Systems).

One very useful tool is a SmartTweezer RLC meter from Advance Devices (*Figure 10*). This small tweezer can help you identify surface mount (or leaded) resistors, capacitors, or inductors. The calculation is fast and because it



Figure 10 - The SmartTweezer RLC meter is helpful for measuring surface-mount components. Pictured is the Advance Devices model ST5, that costs \$387 through their web site (<http://www.advancedevices.com>).

measures both the real and imaginary parts, can also read out ESR or ESL of components. The accuracy is comparable to lab-grade analyzers, and will easily fit in your kit.

OSCILLOSCOPES

I'd like to discuss one last piece of recommended equipment - oscilloscopes. While a good oscilloscope won't fit in your transit case, they do prove to be handy for troubleshooting EMI issues, but in the time domain, rather than in the frequency domain. For example, oscilloscopes can measure transient events, whereas most swept spectrum analyzers are limited to periodic waveforms that are continuous. An oscilloscope is a very useful troubleshooting tool that may be used to examine digital waveforms for ringing and measuring rise times. Many digital models have a wide enough bandwidth to capture ESD and other impulsive signals, enabling you to track the signals through your circuitry.

For general-purpose troubleshooting, the minimum recommended model would be a 500 MHz to 1 GHz bandwidth and at least 4GSa/s, or more. Examples might include the Keysight Technologies MSO-X 3000 series (*Figure 11*). There are many equivalent models from Rhode & Schwarz, Rigol Electronics, Siglent, Tektronix, and Teledyne-LeCroy.

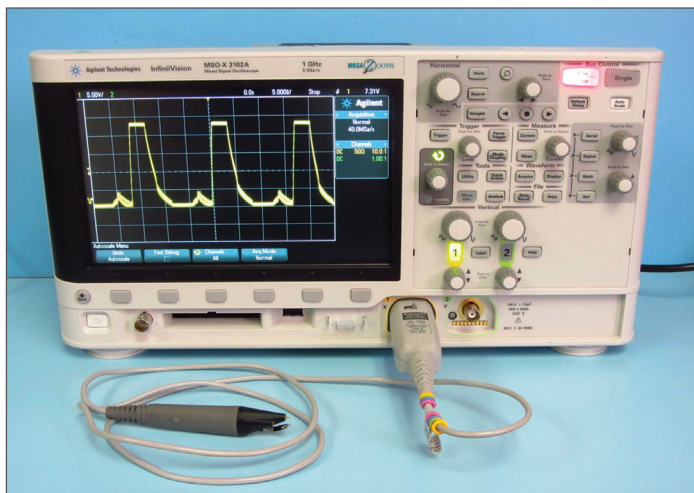

Figure 11 - A useful EMC troubleshooting tool is a digitizing oscilloscope, such as the Keysight MSO-X 3102A with N2976A 2 GHz active probe pictured here.

When measuring high-frequency clock signals, be sure the bandwidth of the oscilloscope and probe exceed the measurement you're making. Minimize the length of the signal return lead of the probe. Using the typical 4 to 6 inch probe ground wire will just accentuate ringing due to the high

self-inductance created by the measurement loop area. I advise using the small solder-in probe sockets sold by the top oscilloscope manufacturers (*Figure 12*). An alternative would be to solder the probe right into the circuitry or to use a 1/4-inch (or shorter) probe ground or signal return connection. An alternative would be to use one of the high frequency active probes, such as the Keysight Technologies model N2976A 2 GHz probe or Rohde & Schwarz 1.5 GHz model RT-ZS20 probe, or equivalent.

Most oscilloscopes today have a fast Fourier transform (FFT) math function that converts time domain signals to the frequency domain. While this could be potentially helpful in troubleshooting, one of the issues is lack of dynamic range and input sensitivity. Most low-cost oscilloscopes can capture only eight bits of data, so very small signals can be buried in the noise floor and may be difficult to observe.

Some of the more expensive models, such as the Rohde & Schwarz RTO or RTE-series have 14-bit acquisition and are sensitive to 1 mV/division. These models are ideal for troubleshooting EMC issues in both the frequency and time domains. Other manufacturers also offer higher

analog-to-digital resolution, better sensitivity, and lower noise, and thus are more useful.

As you can see, the large 217 MHz ringing in the example of *Figure 13* has potentially caused large broadband radiated emissions as measured by a current probe on the power supply input and output circuit (marker 1 and 2 in *Figure 14*).

It's also possible to use near-field probes (H- or E-field) with oscilloscopes. In fact, using one channel as a reference, you can probe with the other to determine correlations between a known noise source and other signals (*Figure 15*).

MISCELLANEOUS CONTENTS

The following is a list of “small stuff” that you might find very handy (in no particular order).

- Small digital multimeter
- Small driver kit (with an assortment of bits)
- Various hand tools
- Power screwdriver, such as the Ryobi Model HP53L (\$30)



Figure 12 - An example of miniature oscilloscope probe sockets for high-frequency measurements. These eliminate the issue of long ground leads that can compromise the signal measurement and cause ringing. They are typically soldered directly to the PC board under test. The spring-loaded oscilloscope probe tip is pulled off and the tip is inserted directly into the socket.

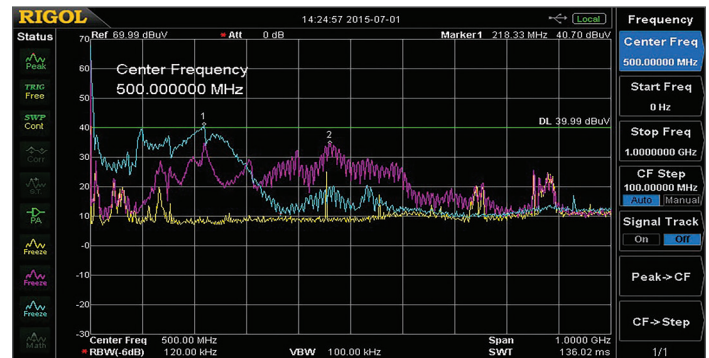

Figure 12 - An example of miniature oscilloscope probe sockets for high-frequency measurements. These eliminate the issue of long ground leads that can compromise the signal measurement and cause ringing. They are typically soldered directly to the PC board under test. The spring-loaded oscilloscope probe tip is pulled off and the tip is inserted directly into the socket.

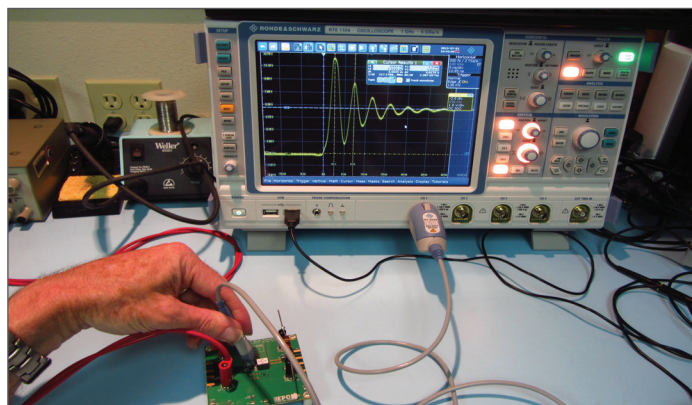

Figure 13 - A high-bandwidth digital oscilloscope is very useful for identifying ringing on clock traces and power buses, as shown here. In this example, we're measuring the ringing from a 1 MHz DC-DC buck converter. The large ring frequency is 217 MHz as measured with a Rohde & Schwarz RTE 1104 oscilloscope and RT-ZS20 1.5 GHz active probe.

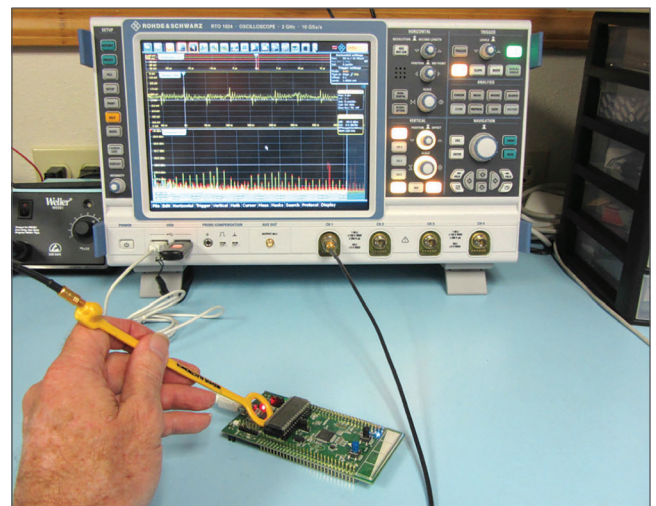

Figure 15 - Troubleshooting an embedded processor board for EMI using the FFT function (lower trace) using a Rohde & Schwarz RTO 1024 oscilloscope.

- SMA connector wrench
- Pencil soldering iron (Weller WM120, \$40)
- Solder and solder-wick
- Dental inspection mirror (small mirror with long thin handle for probing in confined spots)
- Small flashlight
- Small magnifier
- ESD wrist strap
- Tape measure (English/metric)
- Tweezers
- X-Acto knife
- Emory cloth (for sanding away paint)
- Wire (miscellaneous sizes and lengths)
- 10 and 20dB attenuators (Mini-Circuits VAT-10W2, VAT-20W2 and HAT-10+, HAT-20+, \$12 and \$9, respectively, in SMA and/or BNC sizes)
- Various coaxial adapters
- Aluminum foil (1-2 foot square pieces folded)
- Copper tape (or “snail tape”, available from hardware/gardening stores at less than \$10)
- Insulating Kapton® tape
- EMI gaskets (ask manufacturers for a sample kit)
- Ferrite chokes (chip and leaded beads, clamp-on chokes, ask for a sample kit)
- Capacitors (various values, chip and leaded, in range of values: 100 pF, 1/10/100 nF, 1/10 uF)
- Resistors (various values, chip and leaded in range of values: 1/10/27/47/100/470/1k/10k/100k Ohms)
- Inductors (various values, chip and leaded in range of values: 1/10/100/1000 uH)
- Common-mode chokes (chip and leaded, ask for sample kit)
- External line filter with short line plug (used in-between line cord and product as additional external filtering)
- Small (5x5” bare) copper clad PC board (used for

shield – place in a plastic sandwich bag for insulation)

- Clip leads (1m long)
- Various 1m long I/O cables (USB, RS-232, Video VGA, etc.)
- Various BNC and SMA coaxial cables
- Plastic bag with a few coins for generating ESD
- EMI gaskets (ask manufacturers for a sample kit)
- Various BNC and SMA coaxial cables

CONCLUSION

This wraps up the description of my EMC troubleshooting kit. As you have probably observed, not all the recommended equipment will fit inside the Pelican transit case. However, if you do need to travel light, most of the important troubleshooting components will fit, along with the recommended TTI PSA2702T spectrum analyzer or either the Tektronix RSA306 or Signal Hound BB60C real-time analyzers.

REFERENCES

- [1] Inexpensive Radiated Immunity Pre-Compliance Testing: <http://www.interferencetechnology.com/inexpensive-radiated-immunity-pre-compliance-testing/>

For more information, feel free to check my web site at <http://www.emc-seminars.com>, my EMC blog at <http://www.design-4-emc.com>, or *Interference Technology* at <http://www.interferencetechnology.com>.

Kenneth Wyatt is an independent consultant and specialist in electromagnetic compatibility (EMC) design, test and troubleshooting. He may be reached at ken@emc-seminars.com for consultation.



RF & Microwave Power Amplifiers
The World's Most Reliable High Performance Solid-State Amplifiers

FS Amplifier

OPEN/SHORT TOLERANCE

- *Virtually Unlimited Survival Time!*
- *Maximum Output Power!*

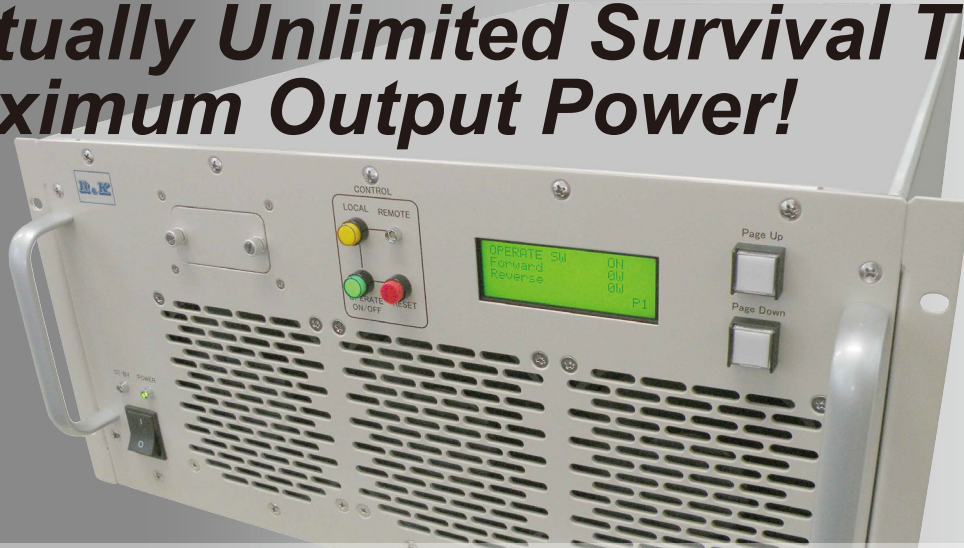

The new FS Series of Class A solid state amplifiers from R&K incorporates an innovative "Fail-Safe Amplifier (FSA)" design. In the event of operational errors or load fluctuations, integrated reverse power protection FSA circuitry ensure the amplifier remains in a safe and damage free operational state under a wide range of load conditions.

The novel FSA design provides reverse power protection over a wide impedance range and extended periods of time without shutdown or severe output limitations.

Many other amplifier manufacturers make similar claims. But the new FS amplifier design, which leverages over 40 years of R&K RF design experience, delivers the highest reliability and performance of any impedance tolerant amplifier on the market.

Contact your local sales representative or R&K to learn more!

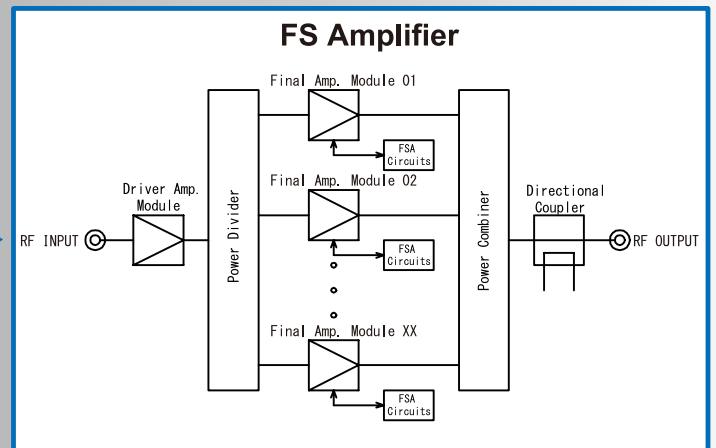
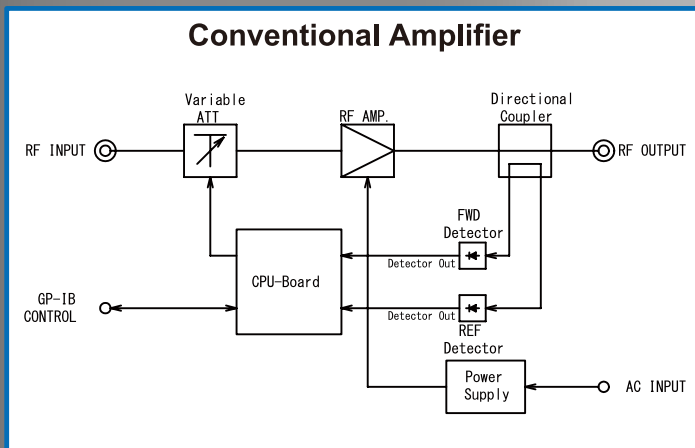

www.rk-microwave.com

Headquarters

R&K R&K Company Limited

721-1 Maeda, Fuji-City, Shizuoka, 416-8577 Japan

Tel: +81-545-31-2600

Fax: +81-545-31-1600

Email: info@rkco.jp



US Sales Partner

CORNES Technologies USA

780 Montague Expy. Ste. 506 San Jose, CA 95131-1319 USA

Tel: +1-408-520-4550

Fax: +1-408-520-4551

Email: rkproducts@cornestech.com



INTERFERENCE TECHNOLOGY EMC TESTING

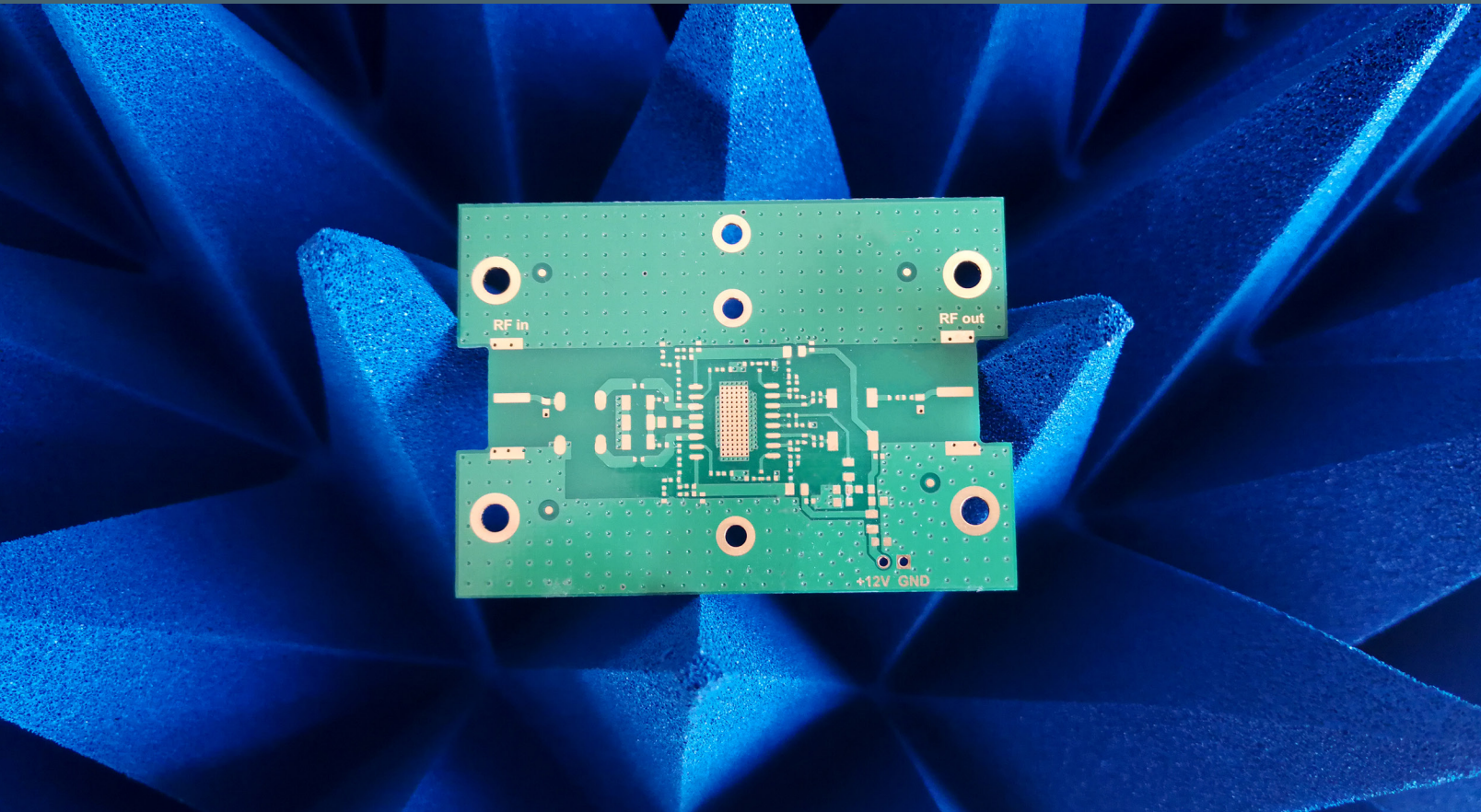

EMC EQUIPMENT MANUFACTURERS SUPPLIER MATRIX

Introduction

The following chart is a quick reference guide of test equipment and includes everything you'll need from the bare minimum required for key evaluation testing, probing, and troubleshooting, to setting up a full in-house precompliance or full compliance test lab. The list includes amplifiers, antennas, current probes, ESD simulators, LISNs, near field probes, RF signal generators, spectrum analyzers, EMI receivers, and TEM cells. Equipment rental companies are also listed. The products listed can help you evaluate radiated and conducted emissions, radiated and conducted immunity, and a host of other immunity tests, such as ESD and EFT.

EMC Equipment Manufacturers Supplier Matrix		Type of Product/Service												
Manufacturer	Contact Information - URL	Antennas	Amplifiers	Near Field Probes	Current Probes	Spectrum Analyzers/EMI Receivers	ESD Simulators	LISNs	Radiated Immunity	Conducted Immunity	Pre-Compliance Test	TEM Cells	Rental Companies	RF Signal Generators
A.H. Systems	www.ahsystems.com	X	X		X						X			
Aaronia AG	www.aaronia.com	X	X			X					X			
Advanced Test Equipment Rentals	www.atecorp.com/category/emc-compliance-esd-rfi-emi.aspx	X	X			X	X	X	X	X	X		X	X
AR RF/Microwave Instrumentation	www.arworld.us	X	X			X		X	X	X	X			X
Anritsu	www.anritsu.com					X					X			X
BHD Test and Measurement	www.bhdtm.com		X			X	X	X	X	X	X		X	X
Compliance Worldwide	www.complianceworldwide.com								X	X	X			
CPI	www.cpii.com	X	X			X								
Electro Rent	www.electrorent.com		X			X	X	X	X	X	X		X	X
EM Test	www.emtest.com/home.php									X	X	X		
EMC Partner	www.emc-partner.com						X			X				
Empower RF Systems	www.empowerrf.com		X						X					
Exodus Advanced Communications	www.exoduscomm.com		X											
F2 Laboratories	www.f2labs.com								X	X	X			
Gauss Instruments	www.gauss-instruments.com/en/					X								
Instruments For Industry (IFI)	www.ifi.com		X						X	X				
ITG Electronics, Inc.	www.itg-electronics.com		X											

EMC Equipment Manufacturers Supplier Matrix		Type of Product/Service												
Manufacturer	Contact Information - URL	Antennas	Amplifiers	Near Field Probes	Current Probes	Spectrum Analyzers/EMI Receivers	ESD Simulators	LISNs	Radiated Immunity	Conducted Immunity	Pre-Compliance Test	TEM Cells	Rental Companies	RF Signal Generators
Kent Electronics	www.wa5vjb.com	X												
Keysight Technologies	www.keysight.com/main/home.jsp?cc=US&lc=eng			X		X		X			X			X
Microlease	www.microlease.com/us/home		X			X	X	X	X	X	X		X	X
Milmega	www.milmega.co.uk		X						X	X				
Narda/PMM	www.narda-sts.it/	X	X			X		X	X	X	X			
Noiseken	www.noiseken.com						X			X	X			
Ophir RF	www.ophirrf.com		X							X				
Pearson Electronics	www.pearsonelectronics.com				X									
PPM Test	www.ppmtest.com	X			X						X			
Rigol Technologies	www.rigolna.com			X	X	X					X			X
Rohde & Schwarz	www.rohde-schwarz.com/us/home_48230.html	X	X	X	X	X		X	X	X	X			X
Siglent Technologies	www.siglentamerica.com			X		X					X			X
Signal Hound	www.signalhound.com			X		X					X			X
Solar Electronics	www.solar-emc.com	X			X		X	X		X				
TekBox Technologies	www.tekbox.com		X	X				X			X	X		
Tektronix	www.tek.com			X		X					X			
Teseq	www.teseq.com/en/index.php		X		X		X		X	X	X	X		
Test Equity	www.testequity.com/leasing/		X			X	X	X	X	X	X		X	X
Thermo Keytek	www.thermofisher.com/us/en/home.html						X			X				
Thurlby Thandar (AIM-TTi)	www.aimtti.us					X					X			X
Toyotech (Toyo)	www.toyotechus.com/emc-electromagnetic-compatibility/	X	X			X		X	X		X			
TPI	www.rf-consultant.com													X
Transient Specialists	www.transientspecialists.com								X	X		X		
TRSRenTelCo	www.trs-rentelco.com/SubCategory/EMC_Test_Equipment.aspx	X	X			X		X	X	X	X		X	X
Vectawave Technology	www.vectawave.com		X											
Windfreak Technologies	www.windfreaktech.com													X

COMMON COMMERCIAL EMC STANDARDS

Commercial Electromagnetic Compatibility (EMC) Standards

ANSI	
Document Number	Title
C63.4	Methods of Measurement of Radio-Noise Emissions from Low-Voltage Electrical and Electronic Equipment in the Range of 9 kHz to 40 GHz

IEC	
Document Number	Title
IEC 60050-161	International Electrotechnical Vocabulary. Chapter 161: Electromagnetic compatibility
IEC 60060-1	High-voltage test techniques. Part 1: General definitions and test requirements
IEC 60060-2	High-voltage test techniques - Part 2: Measuring systems
IEC 60060-3	High-voltage test techniques - Part 3: Definitions and requirements for on-site testing
IEC 60118-13	Electroacoustics - Hearing aids - Part 13: Electromagnetic compatibility (EMC)
IEC 60255-26	Measuring relays and protection equipment - Part 26: Electromagnetic compatibility requirements
IEC 60364-4-44	Low-voltage electrical installations - Part 4-44: Protection for safety - Protection against voltage disturbances and electromagnetic disturbance
IEC 60469	Transitions, pulses and related waveforms - Terms, definitions and algorithms
IEC 60533	Electrical and electronic installations in ships - Electromagnetic compatibility (EMC) - Ships with a metallic hull
IEC 60601-1-2	Medical electrical equipment - Part 1-2: General requirements for basic safety and essential performance - Collateral Standard: Electromagnetic disturbances - Requirements and tests
IEC 60601-2-2	Medical electrical equipment - Part 2-2: Particular requirements for the basic safety and essential performance of high frequency surgical equipment and high frequency surgical accessories
IEC 60601-4-2	Medical electrical equipment - Part 4-2: Guidance and interpretation - Electromagnetic immunity: performance of medical electrical equipment and medical electrical systems
IEC 60728-2	Cabled distribution systems for television and sound signals - Part 2: Electromagnetic compatibility for equipment
IEC 60728-12	Cabled distribution systems for television and sound signals - Part 12: Electromagnetic compatibility of systems

IEC (continued)	
Document Number	Title
IEC/TS 60816	Guide on methods of measurement of short duration transients on low-voltage power and signal lines
IEC 60870-2-1	Telecontrol equipment and systems - Part 2: Operating conditions - Section 1: Power supply and electromagnetic compatibility
IEC 60940	Guidance information on the application of capacitors, resistors, inductors and complete filter units for electromagnetic interference suppression
IEC 60974-10	Arc welding equipment - Part 10: Electromagnetic compatibility (EMC) requirements
IEC/TR 61000-1-1	Electromagnetic compatibility (EMC) - Part 1: General - Section 1: Application and interpretation of fundamental definitions and terms
IEC/TS 61000-1-2	Electromagnetic compatibility (EMC) - Part 1-2: General - Methodology for the achievement of the functional safety of electrical and electronic equipment with regard to electromagnetic phenomena
IEC/TR 61000-1-3	Electromagnetic compatibility (EMC) - Part 1-3: General - The effects of high-altitude EMP (HEMP) on civil equipment and systems
IEC/TR 61000-1-4	Electromagnetic compatibility (EMC) - Part 1-4: General - Historical rationale for the limitation of power-frequency conducted harmonic current emissions from equipment, in the frequency range up to 2 kHz
IEC/TR 61000-1-5	Electromagnetic compatibility (EMC) - Part 1-5: General - High power electromagnetic (HPEM) effects on civil systems
IEC/TR 61000-1-6	Electromagnetic compatibility (EMC) - Part 1-6: General - Guide to the assessment of measurement uncertainty
IEC/TR 61000-1-7	Electromagnetic compatibility (EMC) - Part 1-7: General - Power factor in single-phase systems under non-sinusoidal conditions
IEC/TR 61000-2-1	Electromagnetic compatibility (EMC) - Part 2: Environment - Section 1: Description of the environment - Electromagnetic environment for low-frequency conducted disturbances and signaling in public power supply systems
IEC 61000-2-2	Electromagnetic compatibility (EMC) - Part 2-2: Environment - Compatibility levels for low-frequency conducted disturbances and signaling in public low-voltage power supply systems
IEC/TR 61000-2-3	Electromagnetic compatibility (EMC) - Part 2: Environment - Section 3: Description of the environment - Radiated and non-network-frequency-related conducted phenomena

IEC (continued)	
Document Number	Title
IEC 61000-2-4	Electromagnetic compatibility (EMC) - Part 2-4: Environment - Compatibility levels in industrial plants for low-frequency conducted disturbances
IEC/TS 61000-2-5	Electromagnetic compatibility (EMC) - Part 2: Environment - Section 5: Classification of electromagnetic environments. Basic EMC publication
IEC/TR 61000-2-6	Electromagnetic compatibility (EMC) - Part 2: Environment - Section 6: Assessment of the emission levels in the power supply of industrial plants as regards low-frequency conducted disturbances
IEC/TR 61000-2-7	Electromagnetic compatibility (EMC) - Part 2: Environment - Section 7: Low frequency magnetic fields in various environments
IEC/TR 61000-2-8	Electromagnetic compatibility (EMC) - Part 2-8: Environment - Voltage dips and short interruptions on public electric power supply systems with statistical measurement results
IEC 61000-2-9	Electromagnetic compatibility (EMC) - Part 2: Environment - Section 9: Description of HEMP environment - Radiated disturbance. Basic EMC publication
IEC 61000-2-10	Electromagnetic compatibility (EMC) - Part 2-10: Environment - Description of HEMP environment - Conducted disturbance
IEC 61000-2-11	Electromagnetic compatibility (EMC) - Part 2-11: Environment - Classification of HEMP environments
IEC 61000-2-12	Electromagnetic compatibility (EMC) - Part 2-12: Environment - Compatibility levels for low-frequency conducted disturbances and signaling in public medium-voltage power supply systems
IEC 61000-2-13	Electromagnetic compatibility (EMC) - Part 2-13: Environment - High-power electromagnetic (HPEM) environments - Radiated and conducted
IEC/TR 61000-2-14	Electromagnetic compatibility (EMC) - Part 2-14: Environment - Overvoltages on public electricity distribution networks
IEC 61000-3-2	Electromagnetic compatibility (EMC) - Part 3-2: Limits - Limits for harmonic current emissions (equipment input current ≤ 16 A per phase)
IEC 61000-3-3	Electromagnetic compatibility (EMC) - Part 3-3: Limits - Limitation of voltage changes, voltage fluctuations and flicker in public low-voltage supply systems, for equipment with rated current ≤ 16 A per phase and not subject to conditional connection
IEC/TS 61000-3-4	Electromagnetic compatibility (EMC) - Part 3-4: Limits - Limitation of emission of harmonic currents in low-voltage power supply systems for equipment with rated current greater than 16 A
IEC/TS 61000-3-5	Electromagnetic compatibility (EMC) - Part 3: Limits - Section 5: Limitation of voltage fluctuations and flicker in low-voltage power supply systems for equipment with rated current greater than 16 A
IEC/TR 61000-3-6	Electromagnetic compatibility (EMC) - Part 3: Limits - Section 6: Assessment of emission limits for distorting loads in MV and HV power systems - Basic EMC publication
IEC/TR 61000-3-7	Electromagnetic compatibility (EMC) - Part 3: Limits - Section 7: Assessment of emission limits for fluctuating loads in MV and HV power systems - Basic EMC publication
IEC 61000-3-8	Electromagnetic compatibility (EMC) - Part 3: Limits - Section 8: Signaling on low-voltage electrical installations - Emission levels, frequency bands and electromagnetic disturbance levels
IEC 61000-3-11	Electromagnetic compatibility (EMC) - Part 3-11: Limits - Limitation of voltage changes, voltage fluctuations and flicker in public low-voltage supply systems - Equipment with rated current ≤ 75 A and subject to conditional connection

IEC (continued)	
Document Number	Title
IEC 61000-3-12	Electromagnetic compatibility (EMC) - Part 3-12: Limits - Limits for harmonic currents produced by equipment connected to public low-voltage systems with input current >16 A and ≤ 75 A per phase
IEC/TR 61000-3-13	Electromagnetic compatibility (EMC) - Part 3-13: Limits - Assessment of emission limits for the connection of unbalanced installations to MV, HV and EHV power systems
IEC/TR 61000-3-14	Electromagnetic compatibility (EMC) - Part 3-14: Assessment of emission limits for harmonics, interharmonics, voltage fluctuations and unbalance for the connection of disturbing installations to LV power systems
IEC/TR 61000-3-15	Electromagnetic compatibility (EMC) - Part 3-15: Limits - Assessment of low frequency electromagnetic immunity and emission requirements for dispersed generation systems in LV network
IEC TR 61000-4-1	Electromagnetic compatibility (EMC) - Part 4-1: Testing and measurement techniques - Overview of IEC 61000-4 series
IEC 61000-4-2	Electromagnetic compatibility (EMC) - Part 4-2: Testing and measurement techniques - Electrostatic discharge immunity test
IEC 61000-4-3	Electromagnetic compatibility (EMC) - Part 4-3: Testing and measurement techniques - Radiated, radio-frequency, electromagnetic field immunity test
IEC 61000-4-4	Electromagnetic compatibility (EMC) - Part 4-4: Testing and measurement techniques - Electrical fast transient/burst immunity test
IEC 61000-4-5	Electromagnetic compatibility (EMC) - Part 4-5: Testing and measurement techniques - Surge immunity test
IEC 61000-4-6	Electromagnetic compatibility (EMC) - Part 4-6: Testing and measurement techniques - Immunity to conducted disturbances, induced by radio-frequency fields
IEC 61000-4-7	Electromagnetic compatibility (EMC) - Part 4-7: Testing and measurement techniques - General guide on harmonics and interharmonics measurements and instrumentation, for power supply systems and equipment connected thereto
IEC 61000-4-8	Electromagnetic compatibility (EMC) - Part 4-8: Testing and measurement techniques - Power frequency magnetic field immunity test
IEC 61000-4-9	Electromagnetic compatibility (EMC) - Part 4-9: Testing and measurement techniques - Impulse magnetic field immunity test
IEC 61000-4-10	Electromagnetic compatibility (EMC) - Part 4-10: Testing and measurement techniques - Damped oscillatory magnetic field immunity test
IEC 61000-4-11	Electromagnetic compatibility (EMC) - Part 4-11: Testing and measurement techniques - Voltage dips, short interruptions and voltage variations immunity tests
IEC 61000-4-12	Electromagnetic compatibility (EMC) - Part 4-12: Testing and measurement techniques - Ring wave immunity test
IEC 61000-4-13	Electromagnetic compatibility (EMC) - Part 4-13: Testing and measurement techniques - Harmonics and interharmonics including mains signaling at a.c. power port, low frequency immunity tests
IEC 61000-4-14	Electromagnetic compatibility (EMC) - Part 4-14: Testing and measurement techniques - Voltage fluctuation immunity test
IEC 61000-4-15	Electromagnetic compatibility (EMC) - Part 4: Testing and measurement techniques - Section 15: Flickermeter - Functional and design specifications
IEC 61000-4-16	Electromagnetic compatibility (EMC) - Part 4-16: Testing and measurement techniques - Test for immunity to conducted, common mode disturbances in the frequency range 0 Hz to 150 kHz

IEC (continued)	
Document Number	Title
IEC 61000-4-17	Electromagnetic compatibility (EMC) - Part 4-17: Testing and measurement techniques - Ripple on d.c. input power port immunity test
IEC 61000-4-18	Electromagnetic compatibility (EMC) - Part 4-18: Testing and measurement techniques - Damped oscillatory wave immunity test
IEC 61000-4-19	Electromagnetic compatibility (EMC) - Part 4-19: Testing and measurement techniques - Test for immunity to conducted, differential mode disturbances and signalling in the frequency range 2 kHz to 150 kHz at a.c. power ports
IEC 61000-4-20	Electromagnetic compatibility (EMC) - Part 4-20: Testing and measurement techniques - Emission and immunity testing in transverse electromagnetic (TEM) waveguides
IEC 61000-4-21	Electromagnetic compatibility (EMC) - Part 4-21: Testing and measurement techniques - Reverberation chamber test methods
IEC 61000-4-22	Electromagnetic compatibility (EMC) - Part 4-22: Testing and measurement techniques - Radiated emissions and immunity measurements in fully anechoic rooms (FARs)
IEC 61000-4-23	Electromagnetic compatibility (EMC) - Part 4-23: Testing and measurement techniques - Test methods for protective devices for HEMP and other radiated disturbances
IEC 61000-4-24	Electromagnetic compatibility (EMC) - Part 4-24: Testing and measurement techniques - Test methods for protective devices for HEMP conducted disturbance
IEC 61000-4-25	Electromagnetic compatibility (EMC) - Part 4-25: Testing and measurement techniques - HEMP immunity test methods for equipment and systems
IEC 61000-4-27	Electromagnetic compatibility (EMC) - Part 4-27: Testing and measurement techniques - Unbalance, immunity test
IEC 61000-4-28	Electromagnetic compatibility (EMC) - Part 4-28: Testing and measurement techniques - Variation of power frequency, immunity test
IEC 61000-4-29	Electromagnetic compatibility (EMC) - Part 4-29: Testing and measurement techniques - Voltage dips, short interruptions and voltage variations on d.c. input power port immunity tests
IEC 61000-4-30	Electromagnetic compatibility (EMC) - Part 4-30: Testing and measurement techniques - Power quality measurement methods
IEC 61000-4-31	Electromagnetic compatibility (EMC) - Part 4-31: Testing and measurement techniques - AC mains ports broadband conducted disturbance immunity test
IEC/TR 61000-4-32	Electromagnetic compatibility (EMC) - Part 4-32: Testing and measurement techniques - High-altitude electromagnetic pulse (HEMP) simulator compendium
IEC 61000-4-33	Electromagnetic compatibility (EMC) - Part 4-33: Testing and measurement techniques - Measurement methods for high-power transient parameters
IEC 61000-4-34	Electromagnetic compatibility (EMC) - Part 4-34: Testing and measurement techniques - Voltage dips, short interruptions and voltage variations immunity tests for equipment with input current more than 16 A per phase
IEC TR 61000-4-35	Electromagnetic compatibility (EMC) - Part 4-35: Testing and measurement techniques - HPEM simulator compendium
IEC 61000-4-36	Electromagnetic compatibility (EMC) - Part 4-36: Testing and measurement techniques - IEMI immunity test methods for equipment and systems
IEC TR 61000-4-37	Electromagnetic compatibility (EMC) - Calibration and verification protocol for harmonic emission compliance test systems
IEC TR 61000-4-38	Electromagnetic compatibility (EMC) - Part 4-38: Testing and measurement techniques - Test, verification and calibration protocol for voltage fluctuation and flicker compliance test systems

IEC (continued)	
Document Number	Title
IEC/TR 61000-5-1	Electromagnetic compatibility (EMC) - Part 5: Installation and mitigation guidelines - Section 1: General considerations - Basic EMC publication
IEC/TR 61000-5-2	Electromagnetic compatibility (EMC) - Part 5: Installation and mitigation guidelines - Section 2: Earthing and cabling
IEC/TR 61000-5-3	Electromagnetic compatibility (EMC) - Part 5-3: Installation and mitigation guidelines - HEMP protection concepts
IEC/TS 61000-5-4	Electromagnetic compatibility (EMC) - Part 5: Installation and mitigation guidelines - Section 4: Immunity to HEMP - Specifications for protective devices against HEMP radiated disturbance. Basic EMC Publication
IEC 61000-5-5	Electromagnetic compatibility (EMC) - Part 5: Installation and mitigation guidelines - Section 5: Specification of protective devices for HEMP conducted disturbance. Basic EMC Publication
IEC/TR 61000-5-6	Electromagnetic compatibility (EMC) - Part 5-6: Installation and mitigation guidelines - Mitigation of external EM influences
IEC 61000-5-7	Electromagnetic compatibility (EMC) - Part 5-7: Installation and mitigation guidelines - Degrees of protection provided by enclosures against electromagnetic disturbances (EM code)
IEC 61000-5-8	Electromagnetic compatibility (EMC) - Part 5-8: Installation and mitigation guidelines - HEMP protection methods for the distributed infrastructure
IEC 61000-5-9	Electromagnetic compatibility (EMC) - Part 5-9: Installation and mitigation guidelines - System-level susceptibility assessments for HEMP and HPEM
IEC 61000-6-1	Electromagnetic compatibility (EMC) - Part 6-1: Generic standards - Immunity standard for residential, commercial and light-industrial environments
IEC 61000-6-2	Electromagnetic compatibility (EMC) - Part 6-2: Generic standards - Immunity standard for industrial environments
IEC 61000-6-3	Electromagnetic compatibility (EMC) - Part 6-3: Generic standards - Emission standard for residential, commercial and light-industrial environments
IEC 61000-6-4	Electromagnetic compatibility (EMC) - Part 6-4: Generic standards - Emission standard for industrial environments
IEC 61000-6-5	Electromagnetic compatibility (EMC) - Part 6-5: Generic standards - Immunity for power station and substation environments
IEC 61000-6-6	Electromagnetic compatibility (EMC) - Part 6-6: Generic standards - HEMP immunity for indoor equipment
IEC 61000-6-7	Electromagnetic compatibility (EMC) - Part 6-7: Generic standards - Immunity requirements for equipment intended to perform functions in a safety-related system (functional safety) in industrial locations
IEC 61326-1	Electrical equipment for measurement, control and laboratory use - EMC requirements - Part 1: General requirements
IEC 61326-2-1	Electrical equipment for measurement, control and laboratory use - EMC requirements - Part 2-1: Particular requirements - Test configurations, operational conditions and performance criteria for sensitive test and measurement equipment for EMC unprotected applications
IEC 61326-2-2	Electrical equipment for measurement, control and laboratory use - EMC requirements - Part 2-2: Particular requirements - Test configurations, operational conditions and performance criteria for portable test, measuring and monitoring equipment used in low-voltage distribution systems

IEC (continued)	
Document Number	Title
IEC 61326-2-3	Electrical equipment for measurement, control and laboratory use - EMC requirements - Part 2-3: Particular requirements - Test configuration, operational conditions and performance criteria for transducers with integrated or remote signal conditioning
IEC 61326-2-4	Electrical equipment for measurement, control and laboratory use - EMC requirements - Part 2-4: Particular requirements - Test configurations, operational conditions and performance criteria for insulation monitoring devices according to IEC 61557-8 and for equipment for insulation fault location according to IEC 61557-9
IEC 61326-2-5	Electrical equipment for measurement, control and laboratory use - EMC requirements - Part 2-5: Particular requirements - Test configurations, operational conditions and performance criteria for field devices with field bus interfaces according to IEC 61784-1
IEC 61326-2-6	Electrical equipment for measurement, control and laboratory use - EMC requirements - Part 2-6: Particular requirements - In vitro diagnostic (IVD) medical equipment
IEC 61326-3-1	Electrical equipment for measurement, control and laboratory use - EMC requirements - Part 3-1: Immunity requirements for safety-related systems and for equipment intended to perform safety-related functions (functional safety) - General industrial applications
IEC 61326-3-2	Electrical equipment for measurement, control and laboratory use - EMC requirements - Part 3-2: Immunity requirements for safety-related systems and for equipment intended to perform safety-related functions (functional safety) - Industrial applications with specified electromagnetic environment
IEC 61340-3-1	Electrostatics - Part 3-1: Methods for simulation of electrostatic effects - Human body model (HBM) electrostatic discharge test waveforms
IEC 61543	Residual current-operated protective devices (RCDs) for household and similar use - Electromagnetic compatibility
IEC 61800-3	Adjustable speed electrical power drive systems - Part 3: EMC requirements and specific test methods
IEC 61967-1	Integrated circuits - Measurement of electromagnetic emissions, 150 kHz to 1 GHz - Part 1: General conditions and definitions
IEC 62040-2	Uninterruptible power systems (UPS) - Part 2: Electromagnetic compatibility (EMC) requirements
IEC 62041	Power transformers, power supply units, reactors and similar products - EMC requirements
IEC 62153-4-0	Metallic communication cable test methods - Part 4-0: Electromagnetic compatibility (EMC) - Relationship between surface transfer impedance and screening attenuation, recommended limits
IEC 62153-4-1	Metallic communication cable test methods - Part 4-1: Electromagnetic compatibility (EMC) - Introduction to electromagnetic screening measurements
IEC 62153-4-2	Metallic communication cable test methods - Part 4-2: Electromagnetic compatibility (EMC) - Screening and coupling attenuation - Injection clamp method
IEC 62153-4-3	Metallic communication cable test methods - Part 4-3: Electromagnetic compatibility (EMC) - Surface transfer impedance - Triaxial method
IEC 62153-4-4	Metallic communication cable test methods - Part 4-4: Electromagnetic compatibility (EMC) - Test method for measuring of the screening attenuation as up to and above 3 GHz, triaxial method
IEC 62153-4-5	Metallic communication cables test methods - Part 4-5: Electromagnetic compatibility (EMC) - Coupling or screening attenuation - Absorbing clamp method

IEC (continued)	
Document Number	Title
IEC 62153-4-6	Metallic communication cable test methods - Part 4-6: Electromagnetic compatibility (EMC) - Surface transfer impedance - Line injection method
IEC 62153-4-7	Metallic communication cable test methods - Part 4-7: Electromagnetic compatibility (EMC) - Test method for measuring of transfer impedance ZT and screening attenuation aS or coupling attenuation aC of connectors and assemblies up to and above 3 GHz - Triaxial tube in tube method
IEC 62153-4-8	Metallic communication cable test methods - Part 4-8: Electromagnetic compatibility (EMC) - Capacitive coupling admittance
IEC 62153-4-9	Metallic communication cable test methods - Part 4-9: Electromagnetic compatibility (EMC) - Coupling attenuation of screened balanced cables, triaxial method
IEC 62153-4-10	Metallic communication cable test methods - Part 4-10: Electromagnetic compatibility (EMC) - Transfer impedance and screening attenuation of feed-throughs and electromagnetic gaskets - Double coaxial test method
IEC 62153-4-11	Metallic communication cable test methods - Part 4-11: Electromagnetic compatibility (EMC) - Coupling attenuation or screening attenuation of patch cords, coaxial cable assemblies, pre-connectorized cables - Absorbing clamp method
IEC 62153-4-12	Metallic communication cable test methods - Part 4-12: Electromagnetic compatibility (EMC) - Coupling attenuation or screening attenuation of connecting hardware - Absorbing clamp method
IEC 62153-4-13	Metallic communication cable test methods - Part 4-13: Electromagnetic compatibility (EMC) - Coupling attenuation of links and channels (laboratory conditions) - Absorbing clamp method
IEC 62153-4-14	Metallic communication cable test methods - Part 4-14: Electromagnetic compatibility (EMC) - Coupling attenuation of cable assemblies (Field conditions) absorbing clamp method
IEC 62153-4-15	Metallic communication cable test methods - Part 4-15: Electromagnetic compatibility (EMC) - Test method for measuring transfer impedance and screening attenuation - or coupling attenuation with triaxial cell
IEC 62236-1	Railway applications - Electromagnetic compatibility - Part 1: General
IEC 62236-2	Railway applications - Electromagnetic compatibility - Part 2: Emission of the whole railway system to the outside world
IEC 62236-3-1	Railway applications - Electromagnetic compatibility - Part 3-1: Rolling stock - Train and complete vehicle
IEC 62236-3-2	Railway applications - Electromagnetic compatibility - Part 3-2: Rolling stock - Apparatus
IEC 62236-4	Railway applications - Electromagnetic compatibility - Part 4: Emission and immunity of the signalling and telecommunications apparatus
IEC 62236-5	Railway applications - Electromagnetic compatibility - Part 5: Emission and immunity of fixed power supply installations and apparatus
IEC 62305-1	Protection against lightning - Part 1: General principles
IEC 62305-2	Protection against lightning - Part 2: Risk management
IEC 62305-3	Protection against lightning - Part 3: Physical damage to structures and life hazard

IEC (continued)	
Document Number	Title
IEC 62305-4	Protection against lightning - Part 4: Electrical and electronic systems within structures
IEC 62310-2	Static transfer systems (STS) - Part 2: Electromagnetic compatibility (EMC) requirements
IEC/TR 62482	Electrical installations in ships - Electromagnetic compatibility - Optimising of cable installations on ships - Testing method of routing distance

CISPR	
Document Number	Title
CISPR 11	Industrial, scientific and medical (ISM) radio-frequency equipment - Electromagnetic disturbance characteristics - Limits and methods of measurement
CISPR 12	Vehicles, boats and internal combustion engines - Radio disturbance characteristics - Limits and methods of measurement for the protection of off-board receivers
CISPR 14-1	Electromagnetic compatibility - Requirements for household appliances, electric tools and similar apparatus - Part 1: Emission
CISPR 14-2	Electromagnetic compatibility - Requirements for household appliances, electric tools and similar apparatus - Part 2: Immunity - Product family standard
CISPR 15	Limits and methods of measurement of radio disturbance characteristics of electrical lighting and similar equipment
CISPR 16-1-1	Specification for radio disturbance and immunity measuring apparatus and methods - Part 1-1: Radio disturbance and immunity measuring apparatus - Measuring apparatus
CISPR 16-1-2	Specification for radio disturbance and immunity measuring apparatus and methods - Part 1-2: Radio disturbance and immunity measuring apparatus - Coupling devices for conducted disturbance measurements
CISPR 16-1-3	Specification for radio disturbance and immunity measuring apparatus and methods - Part 1-3: Radio disturbance and immunity measuring apparatus - Ancillary equipment - Disturbance power
CISPR 16-1-4	Specification for radio disturbance and immunity measuring apparatus and methods - Part 1-4: Radio disturbance and immunity measuring apparatus - Antennas and test sites for radiated disturbance measurements
CISPR 16-1-5	Specification for radio disturbance and immunity measuring apparatus and methods - Part 1-5: Radio disturbance and immunity measuring apparatus - Antenna calibration sites and reference test sites for 5 MHz to 18 GHz
CISPR 16-1-6	Specification for radio disturbance and immunity measuring apparatus and methods - Part 1-6: Radio disturbance and immunity measuring apparatus - EMC antenna calibration
CISPR 16-2-1	Specification for radio disturbance and immunity measuring apparatus and methods - Part 2-1: Methods of measurement of disturbances and immunity - Conducted disturbance measurements
CISPR 16-2-2	Specification for radio disturbance and immunity measuring apparatus and methods - Part 2-2: Methods of measurement of disturbances and immunity - Measurement of disturbance power
CISPR 16-2-3	Specification for radio disturbance and immunity measuring apparatus and methods - Part 2-3: Methods of measurement of disturbances and immunity - Radiated disturbance measurements

CISPR (continued)	
Document Number	Title
CISPR 16-2-4	Specification for radio disturbance and immunity measuring apparatus and methods - Part 2-4: Methods of measurement of disturbances and immunity - Immunity measurements
CISPR TR 16-2-5	Specification for radio disturbance and immunity measuring apparatus and methods - Part 2-5: In situ measurements for disturbing emissions produced by physically large equipment
CISPR TR 16-3	Specification for radio disturbance and immunity measuring apparatus and methods - Part 3: CISPR technical reports
CISPR TR 16-4-1	Specification for radio disturbance and immunity measuring apparatus and methods - Part 4-1: Uncertainties, statistics and limit modelling - Uncertainties in standardized EMC tests
CISPR 16-4-2	Specification for radio disturbance and immunity measuring apparatus and methods - Part 4-2: Uncertainties, statistics and limit modelling - Measurement instrumentation uncertainty
CISPR TR 16-4-3	Specification for radio disturbance and immunity measuring apparatus and methods - Part 4-3: Uncertainties, statistics and limit modelling - Statistical considerations in the determination of EMC compliance of mass-produced products
CISPR TR 16-4-4	Specification for radio disturbance and immunity measuring apparatus and methods - Part 4-4: Uncertainties, statistics and limit modelling - Statistics of complaints and a model for the calculation of limits for the protection of radio services
CISPR TR 16-4-5	Specification for radio disturbance and immunity measuring apparatus and methods - Part 4-5: Uncertainties, statistics and limit modelling - Conditions for the use of alternative test methods
CISPR 17	Methods of measurement of the suppression characteristics of passive EMC filtering devices
CISPR TR 18-1	Radio interference characteristics of overhead power lines and high-voltage equipment - Part 1: Description of phenomena
CISPR TR 18-2	Radio interference characteristics of overhead power lines and high-voltage equipment - Part 2: Methods of measurement and procedure for determining limits
CISPR TR 18-3	Radio interference characteristics of overhead power lines and high-voltage equipment - Part 3: Code of practice for minimizing the generation of radio noise
CISPR 20	Sound and television broadcast receivers and associated equipment - Immunity characteristics - Limits and methods of measurement (To be withdrawn in 2020)
CISPR 24	Information technology equipment - Immunity characteristics - Limits and methods of measurement (To be withdrawn in 2020)
CISPR 25	Vehicles, boats and internal combustion engines - Radio disturbance characteristics - Limits and methods of measurement for the protection of on-board receivers
CISPR 32	Electromagnetic compatibility of multimedia equipment - Emission requirements
CISPR 35	Electromagnetic compatibility of multimedia equipment - Immunity requirements

USEFUL EMC TESTING REFERENCES

(DIRECTORY, BOOKS, ORGANIZATIONS, LINKEDIN GROUPS)

RECOMMENDED BOOKS & JOURNALS

André and Wyatt

EMI Troubleshooting Cookbook for Product Designers
SciTech Publishing, 2014.

Includes chapters on product design and EMC theory & measurement. A major part of the content includes how to troubleshoot and mitigate all common commercial EMC test failures.

Archambeault

PCB Design for Real-World EMI Control
Kluwer Academic Publishers, 2002.

Bogatin

Signal & Power Integrity - Simplified
Prentice-Hall, 2018 (3rd Edition).

Great coverage of signal and power integrity from a fields viewpoint.

Hall, Hall, and McCall

High-Speed Digital System Design - A Handbook of Interconnect Theory and Design Practices
Wiley, 2000.

Joffe and Lock

Grounds For Grounding
Wiley, 2010.

This huge book includes way more topics on product design than the title suggests. Covers all aspects of grounding and shielding for products, systems, and facilities.

Johnson and Graham

High-Speed Digital Design - A Handbook of Black Magic
Prentice-Hall, 1993.

Practical coverage of high speed digital signals and measurement.

Johnson and Graham

High-Speed Signal Propagation - Advanced Black Magic
Prentice-Hall, 2003.

Practical coverage of high speed digital signals and measurement.

Kimmel and Gerke

Electromagnetic Compatibility in Medical Equipment
IEEE Press, 1995.

Good general product design information.

Mardiguian

EMI Troubleshooting Techniques
McGraw-Hill, 2000.

Good coverage of EMI troubleshooting.

Mardiguian

Controlling Radiated Emissions by Design
Springer, 2016.

Good content on product design for compliance.

Montrose

EMC Made Simple

Montrose Compliance Services, 2014.

The content includes several important areas of EMC theory and product design, troubleshooting, and measurement.

Morrison

Digital Circuit Boards - Mach 1 GHz
Wiley, 2012.

Important concepts of designing high frequency circuit boards from a fields viewpoint.

Morrison

Grounding And Shielding - Circuits and Interference
Wiley, 2016 (6th Edition).

The classic text on grounding and shielding with up to date content on how RF energy flows through circuit boards.

Morrison

Fast Circuit Boards
Wiley, 2018.

Morrison explains how signals propagate via transmission lines and why it's so important to include reference planes for every signal layer.

Ott

Electromagnetic Compatibility Engineering
Wiley, 2009.

The "bible" on EMC measurement, theory, and product design.

Paul

Introduction to Electromagnetic Compatibility
Wiley, 2006 (2nd Edition).

The one source to go to for an upper-level course on EMC theory.

USEFUL EMC TESTING REFERENCES (CONTINUED)

(DIRECTORY, BOOKS, ORGANIZATIONS, LINKEDIN GROUPS)

RECOMMENDED BOOKS (CONTINUED)

Sandler

Power Integrity - Measuring, Optimizing, and Troubleshooting Power Related Parameters in Electronics Systems
McGraw-Hill, 2014.

The latest information on measurement and design of power distribution networks and how the network affects stability and EMC.

Smith and Bogatin

Principles of Power Integrity for PDN Design - Simplified
Prentice-Hall, 2017.

Getting the power distribution network (PDN) design right is the key to reducing EMI.

Williams

EMC For Product Designers
Newnes, 2017.

Completely updated text on product design for EMC compliance.

Weston

Electromagnetic Compatibility - Methods, Analysis, Circuits, and Measurement
CRC Press, 2017 (3rd Edition).

A comprehensive text, primarily focused on military EMC.

Wyatt

EMC Desk Reference
Interference Technology, 2017.

A handy guide with technical articles and pertinent EMC reference information.

Wyatt & Jost

Electromagnetic Compatibility (EMC) Pocket Guide
SciTech Publishing, 2013.

A handy pocket-sized reference guide to EMC.

EMC STANDARDS ORGANIZATION

ANSI

<http://www.ansi.org>

ANSI Accredited C63

<http://c63.org/index.htm>

IEEE Standards Association

<http://standards.ieee.org>

SAE

<http://www.sae.org>

SAE EMC Standards Committee

<http://www.sae.org/standards/>

IEC

<http://iec.ch>

CISPR

http://www.iec.ch/emc/iec_emc/iec_emc_players_cispr.htm

ETSI

<http://www.etsi.org>

LINKEDIN GROUPS

EMC Experts

EMC Testing and Compliance

Electromagnetic Compatibility Forum

ESD Experts

EMC Troubleshooters

HOW TO PREPARE YOUR PRODUCT AND YOURSELF FOR EMC TESTING

Ghery Pettit

Pettit EMC Consulting

Ghery@PettitEMCConsulting.com

Introduction

Your product has EMC requirements. You have to test it to demonstrate compliance with those requirements. How do you prepare for the test? How do you prepare your product for the test?

These are two different areas that need preparation before you go to the lab. Let's look at them, one at a time.



HOW TO PREPARE YOUR PRODUCT AND YOURSELF FOR EMC TESTING

HOW DO YOU PREPARE FOR THE TEST?

First, you need to understand what you need to gather before going to the lab. A step before that is that you must select a lab to perform the tests. Then, you need to know what information the lab will need prior to the tests in order to allow them to properly test your product and write a test report. Some labs⁹ may require a written test plan before performing the tests, and the contents of the test plan will aid them by gathering information needed for the test reports.

How do you select a lab? First, you need to know what will be required of the laboratory in order for its results to be acceptable in the countries in which you wish to sell your product. Not all labs are acceptable everywhere in the world. The requirements for a lab to be accepted in various parts of the world is beyond the scope of this article, but you should ensure that the lab's results and reports will be acceptable. Some parts of the world have no restrictions on what lab you may use, others may require that the lab be accredited for testing in their country. When in doubt, ask to see proof.

Secondly, mere possession of accreditation is not, in and of itself, evidence that the lab truly does quality work. You should become educated on the requirements around the world and perform your own inspections of the candidate laboratories. Some labs will welcome your visit, others might not. You will have to decide what level of comfort is adequate for your company. If you don't have the expertise in-house you might consider hiring a consultant to evaluate the laboratory or laboratories you are considering.

Once you have settled on a laboratory to perform the tests, find out from the lab what information they need you to provide. Later we'll talk about the information that a laboratory must include in the test report, and you will see that much of it comes from you. Know what information is needed and have it available when you go to the lab. Part of your laboratory selection process should include asking about lead time requirements. Are they so busy that they can't fit in the number of days you will need for the tests until 6 months from now? And you need to ship in 1 month? That is important information. Few things upset management more than being told that they can't start shipping product (and receiving money) until a few months after they had planned. Your fault or not, you will be blamed, so make sure you understand your company's schedule requirements and what the laboratory can deliver.

Also, talk to the lab and have a good idea how long the tests will take and then when they can deliver a test report for your review. Talk to your marketing people to see when they plan on announcing this product and start shipping it. You don't want to be the bottleneck that stops the process. Have these discussions early (both with the lab and with your own people) and keep the information up to date. En-

sure that you keep your management informed of the status and any delays that you see coming.

HOW DO YOU PREPARE THE PRODUCT FOR THE TEST?

First, design the product with EMC in mind. Provide guidance to the development team early and often on design features that they should include to increase their chances of passing the first time. Review the designs to make sure that obvious mistakes are not included in the product design. Perform preliminary development tests when possible to catch mistakes and failures early, when they can more easily be fixed.

Once the product is designed and debugged, make sure that all necessary hardware and software is available for the test. The hardware that you will need to provide to the laboratory may be more than just the box you are testing. What about peripheral devices? Are they common items that the laboratory might already have in their possession? Or are they special items that only you might have? You might also ensure that all subassemblies are installed correctly and that all chassis and enclosure fasteners are tight. What about the cables connecting the various parts of the system? Are specially designed cables necessary?

A classic example to consider is if your product includes an HDMI interface. If your product depends on properly shielded cables, with the shields properly terminated, cables that simply meet the HDMI cable specification may not be adequate. The HDMI specification does not address the termination of the outer shield of the cable and many HDMI compliant cables do not have this outer shield terminated or terminated properly. They meet the HDMI specification, but are not typically adequate from an EMC perspective. Does your product need the shield terminated? Make sure the cables used for the test (and sold with your product) have the shields terminated correctly.

If any software is required in order for your product to be exercised as required by the EMC standard to which it is being tested make sure you pack that software with the product, or pre-install it and test it to make sure it works. Remember that the clock is running when you arrive at the lab and you don't want to be paying their hourly rate to troubleshoot your product to make it work, or waste time running back to your company to get software you forgot.

Also, it's wise to bring the following items: product documentation, installation manual, user manual, extra tools – especially specialized ones required to remove covers or cables, etc., backup copies of software, a backup laptop, backup hardware in case of product failure (especially important for potentially destructive tests like ESD), extra cables, troubleshooting items like ferrite chokes, copper tape, and aluminum foil.

WHAT INFORMATION MIGHT YOU NEED TO PROVIDE TO THE LAB?

The laboratory is going to write a test report (or reports) for

you at the completion of the tests (assuming the product passed, writing a full report for a product that fails is a waste of time and your money). ISO/IEC Guide 17025:2005 provides a list of items that must be included in the test report and regulatory agencies add their own requirements. Let's look at the items that ISO/IEC 17025 requires:

Articles 5.10.2 and 5.10.3 of ISO/IEC 17025 list a number of required items to be included. These are;

- 5.10.2a – The report is labeled with a title, such as “Test Report”
- 5.10.2b – The name and address of the laboratory used for the measurement
- 5.10.2c – Unique identifier of the report on each page and a clear identification of the end of the report
- 5.10.2d – Name and address of the client
- 5.10.2e – Test methods clearly identified
- 5.10.2f –
 - Description of the condition of the EUT
 - Clear and unambiguous identification of the EUT on the cover or first page of the report. All applicable model numbers and manufacturer's trade names are to be listed here
- 5.10.2g – Date(s) of the test shall be identified
- 5.10.2h – reference to the sampling plan and procedures used by the lab (not typically needed in an EMC test report)
- 5.10.2i – test results with units of measurement
- 5.10.2j – name(s), function(s) and signature(s) of person(s) authorizing the test report
- 5.10.2k – a statement to the effect that the results relate only to the items tested
- 5.10.2 Note 1 – hard copies of test reports should include the page number and total number of pages
- 5.10.2 Note 2 – a statement that the test report shall not be reproduced except in full, without written approval of the lab.
- 5.10.3.1a – deviations from, additions to, or exclusions from the test methods, and information on specific test conditions, such as environmental conditions
 - Temperature, humidity, barometric pressure
 - Operating voltage and frequency
- 5.10.3.1b – a statement of compliance/non-compliance with requirements and/or specifications
- 5.10.3.1c – a statement on the estimated uncertainty of measurement
- 5.10.3.1d – where appropriate and needed, opinions and interpretations
- 5.10.3.1e – additional information which may be required by specific methods, customers or groups of customers

In the United States, the Federal Communications Commission (FCC) has some additional requirements. These will vary depending on the type of approval process used

for the product.

DEVICES AUTHORIZED UNDER VERIFICATION

- 47 CFR 2.955(a)(3)
 - i. Indicate the actual date all testing was performed (see also 17025 5.10.2g)
 - ii. State the name of the test laboratory, company, or individual performing the verification testing. (see also 17025 5.10.2b)
 - iii. Contain a description of how the device was actually tested, identifying the measurement procedure and test equipment that was used (see also 17025 5.10.2e)
 - iv. Contain a description of the equipment under test (EUT) and support equipment connected to, or installed within, the EUT (see also 17025 5.10.2f)
 - v. Identify the EUT and support equipment by trade name and model number and, if appropriate, by FCC Identifier and serial number
 - vi. Indicate the types and lengths of connecting cables used and how they were arranged or moved during testing
 - vii. Contain at least two drawings or photographs showing the test set-up for the highest line conducted emission and showing the test set-up for the highest radiated emission. These drawings or photographs must show enough detail to confirm other information contained in the test report. Any photographs used must be focused originals without glare or dark spots and must clearly show the test configuration used
 - viii. List all modifications, if any, made to the EUT by the testing company or individual to achieve compliance with the regulations in this chapter
 - ix. Include all of the data required to show compliance with the appropriate regulations in this chapter (see also 17025 5.10.2i)
 - x. Contain, on the test report, the signature of the individual responsible for testing the product along with the name and signature of an official of the responsible party, as designated in §2.909

DEVICES AUTHORIZED UNDER CERTIFICATION

- 47 CFR 2.1033(b)
 - i. The full name and mailing address of the manufacturer of the device and the applicant for certification (see also 17025 5.10.2d)
 - ii. FCC identifier
 - iii. A copy of the installation and operating instructions to be furnished the user. A draft copy of the instructions may be submitted if the actual document is not available. The actual document shall be furnished to the FCC when it becomes available
 - iv. A brief description of the circuit functions of the device along with a statement describing how the device operates. This statement should contain a description of the ground system and antenna, if any, used with the device
 - v. A block diagram showing the frequency of all oscillators in the device. The signal path and frequency shall be indicated at each block. The tuning range(s) and

intermediate frequency(ies) shall be indicated at each block. A schematic diagram is also required for intentional radiators

- vi. A report of measurements showing compliance with the pertinent FCC technical requirements. This report shall identify the test procedure used (e.g., specify the FCC test procedure, or industry test procedure that was used), the date the measurements were made, the location where the measurements were made, and the device that was tested (model and serial number, if available). The report shall include sample calculations showing how the measurement results were converted for comparison with the technical requirements
- vii. A sufficient number of photographs to clearly show the exterior appearance, the construction, the component placement on the chassis, and the chassis assembly. The exterior views shall show the overall appearance, the antenna used with the device (if any), the controls available to the user, and the required identification label in sufficient detail so that the name and FCC identifier can be read. In lieu of a photograph of the label, a sample label (or facsimile thereof) may be submitted together with a sketch showing where this label will be placed on the equipment. Photographs shall be of size A4 (21 cm x 29.7 cm) or 8 x 10 inches (20.3 cm x 25.4 cm). Smaller photographs may be submitted provided they are sharp and clear, show the necessary detail, and are mounted on A4 (21 cm x 29.7 cm) or 8.5 x 11 inch (21.6 cm x 27.9 cm) paper. A sample label or facsimile together with the sketch showing the placement of this label shall be on the same size paper
- viii. If the equipment for which certification is being sought must be tested with peripheral or accessory devices connected or installed, a brief description of those peripherals or accessories. The peripheral or accessory devices shall be unmodified, commercially available equipment

DEVICES AUTHORIZED UNDER DECLARATION OF CONFORMITY

- 47 CFR 2.1075(a)(3)
 - i. The actual date or dates testing was performed
 - ii. The name of the test laboratory, company, or individual performing the testing. The Commission may request additional information regarding the test site, the test equipment or the qualifications of the company or individual performing the tests
 - iii. A description of how the device was actually tested, identifying the measurement procedure and test equipment that was used
 - iv. A description of the equipment under test (EUT) and support equipment connected to, or installed within, the EUT
 - v. The identification of the EUT and support equipment by trade name and model number and, if appropriate, by FCC Identifier and serial number
 - vi. The types and lengths of connecting cables used and how they were arranged or moved during testing

- vii. At least two photographs showing the test set-up for the highest line conducted emission and showing the test set-up for the highest radiated emission. These photographs must be focused originals which show enough detail to confirm other information contained in the test report
- viii. A description of any modifications made to the EUT by the testing company or individual to achieve compliance with the regulations
- ix. All of the data required to show compliance with the appropriate regulations
- x. The signature of the individual responsible for testing the product along with the name and signature of an official of the responsible party, as designated in §2.909
- xi. A copy of the compliance information, as described in §2.1077, required to be provided with the equipment

In Taiwan, the Bureau of Standards, Metrology and Inspection (BSMI) has a few of their own requirements for report content.

- If testing with different numbers of cables connected to multiple samples of a given I/O port type is performed, data for each number of cables used shall be provided to show that the addition of the final cable did not increase emissions by more than 2 dB.
- A statement that the final test results represent the worst case, along with a listing of the configuration variations that were investigated to determine the worst case.
- Clear photographs of the test setup providing sufficient detail to duplicate the test results. Each test setup must be documented.
 - 6 exterior pictures of a system EUT for class A equipment
 - 6 exterior and 6 interior pictures of a system EUT for class B equipment.
 - Pictures required for the power supply and internal boards. Board photos required of both sides with sufficient detail to identify EMC critical parts.
 - Minimum photo size is 4 by 6 inches
- List of removable EMI suppression components in the product.
- List of key EMI generation components (clock generators and distribution parts)
- Block diagram of the EUT showing the clock distribution
- BSMI cover sheet containing the following information:
 - Product Name. This shall be the same name as provided on shipping and final sales packaging
 - Applicant (Intel for our products)
 - Description of nameplate mains characteristics
 - Logo or Brand
 - Model Number or Type. Detailed model number(s)
 - Test Result. Passed. State class A or class B
 - Original Signature. Electronic signatures are acceptable if the report and all supporting documentation is

submitted on a CD-ROM

The following items may be specific to one regulator, but should be provided in the report:

- List of accreditations, approvals, listings, etc held by the laboratory. Include identification numbers if applicable.
- If multiple model numbers are covered by the report, provide a description and evidence of differences reviewed by the laboratory.
- Name and signature of the person taking the data. Needed for each set of data in the report.
- List all test equipment used during the tests.
 - Test equipment type
 - Manufacturer
 - Model number
 - Serial number
 - Calibration date and calibration due date
- Details of applicable regulatory compliance labels showing label details and location on the product.
- List of all components of the EUT system. Include internal components such as power supplies, motherboards, hard disk drives, floppy disk drives, CD-ROM drives and add-in cards.

- Equipment type
- Manufacturer
- Model number
- Serial number

- List of all cables
 - Length
 - Type (shielded, unshielded, coax, etc)
 - Devices interconnected with the cable
- EUT exercise/stimulation software used
- Any required user warning statements.

As you can see, preparation for testing a product to EMC requirements is an intensive process. You will need to go through this list of information and make sure that any of it that must be provided to the laboratory is identified and provided in a format that is useful to the laboratory.

Talk to them in advance and make sure that you have everything they need, in a format that they can use. The time (and money) that you save is your own (or your employers).



SUMMARY OF COMMERCIAL EMC TESTS

Ghery Pettit

Pettit EMC Consulting

Ghery@PettitEMCConsulting.com

Introduction

Commercial EMC tests cover a wide range of products. These include the obvious ones like computers and their peripherals, but also cover household appliances, electric tools and a wide variety of other products. While the standards, including limits and test methods may differ, all EMC test standards have a few things in common. The most basic are the limits for emissions and the types and levels of immunity testing.

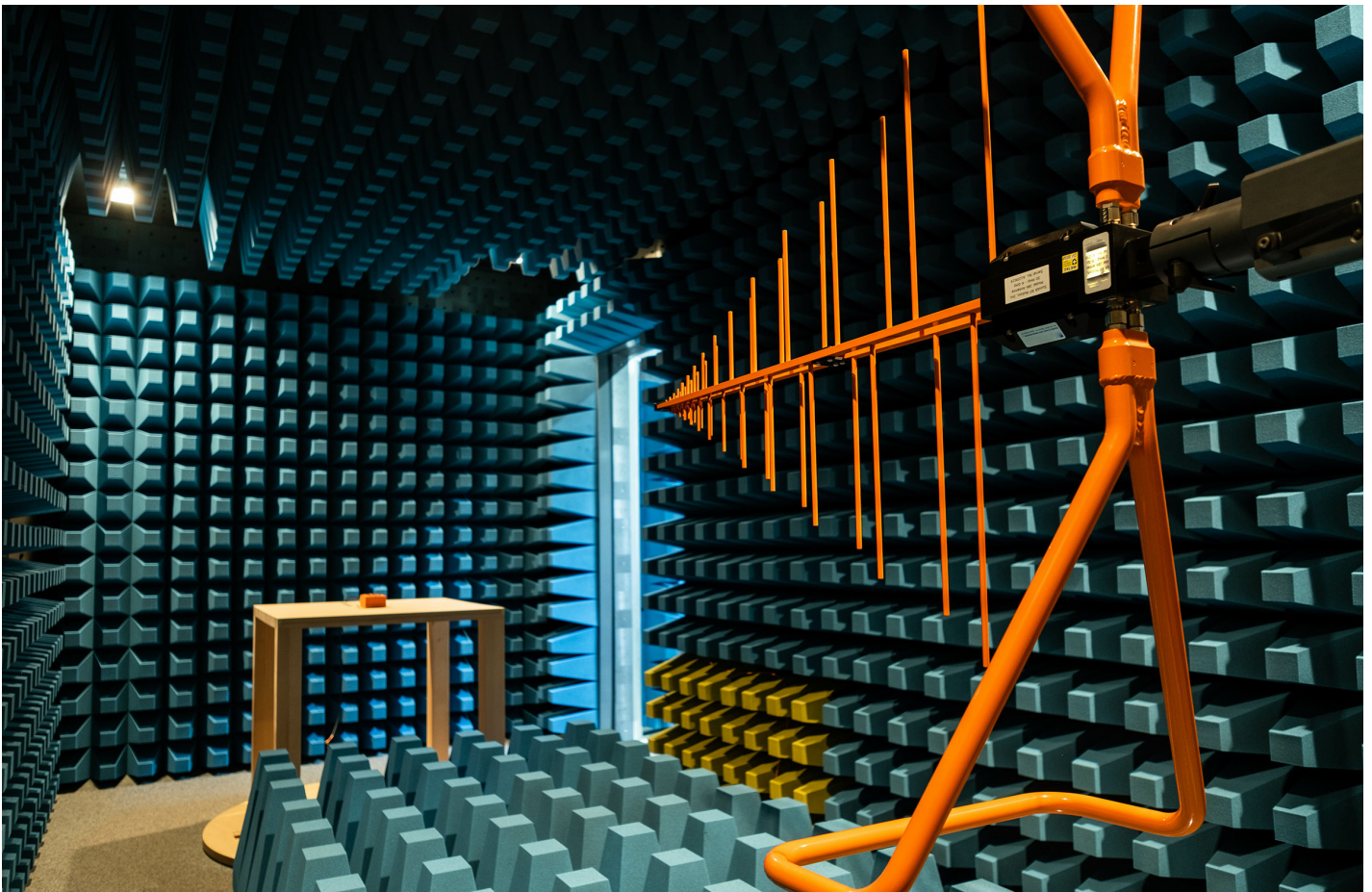

SUMMARY OF COMMERCIAL EMC TESTS

Emissions tests (and their associated limits) are put in place for commercial equipment primarily to protect radio and television broadcasting services. Other radio communications services are also protected. While a very few commercial emissions standards existed prior to the introduction of the personal computer to the marketplace, the proliferation of these devices spurred the development of standards and regulations around the world due to the large number of interference complaints directly traceable to these new devices. Early personal computing devices were designed and built with no regard to controlling radio frequency emissions and, as a result, they generated large amounts of RF emissions. Indeed, it could be argued that the early personal computing devices were broadband radio transmitters masquerading as computers. Mainframe computers had similar weaknesses, but as they typically weren't installed in residential areas the impact was smaller.

Emissions testing typically comprises of two parts. Conducted emissions on power and telecommunications ports and radiated emissions. The breakpoint between the two (conducted and radiated) in commercial standards is 30 MHz. This frequency was chosen as at the typical test distances involved (3 meters and 10 meters today) frequencies above 30 MHz tend to provide plane wave (far field) emissions, allowing for fairly repeatable measurements from laboratory to laboratory. Below 30 MHz this may not be the case. Thus, conducted emissions are measured. Limits for powerline conducted emissions were set based on the source and victim devices being connected to the same circuit. Limits for conducted emissions on telecommunication ports are set assuming a certain conversion of the differential mode (desired) signals on the cable being converted to common mode (due to characteristics of the cable) which then radiates.

CONDUCTED EMISSIONS

Conducted emissions on the incoming power lines are measured (typically) using a Line Impedance Stabilization Network (LISN) or Artificial Mains Network (AMN). These are two different names for the same box. The LISN or AMN is placed between the Equipment Under Test (EUT) and the incoming power line (mains) to provide a defined power line impedance and a coupling point to the receiver (*Figure 1*). The LISN or AMN is placed on the horizontal ground plane, or directly beneath it with the EUT connected directly to the EUT port. The block diagram below shows this test setup.

The EUT is placed either on the horizontal ground plane on the floor (with an insulating spacer) or on an 80 cm high non-conducting table, depending on the intended installation of the EUT (table top or ground mounted). The frequency range of interest is scanned with the appropriate detectors and bandwidth and the results are noted. Measurement are made on each conductor of the incoming line separately. Most commercial EMC standards have mea-

surements made over the frequency range of 150 kHz to 30 MHz.

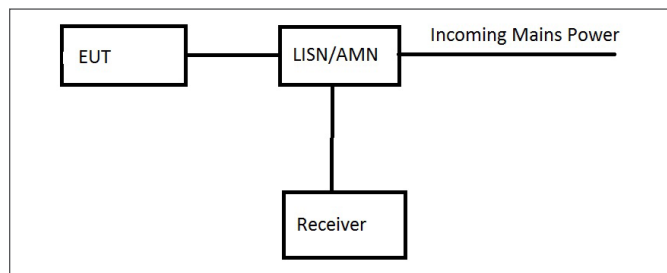

Figure 1 - Generalized test setup for conducted emissions using a line impedance stabilization network (LISN).

RADIATED EMISSIONS

Radiated emissions may be measured in either an Open Area Test Site (OATS) or an RF Semi-Anechoic Chamber (SAC). The OATS is the "gold standard" test facility. It consists of a large open area free of objects which might reflect RF energy. It typically is equipped with a reflecting ground plane. The size of the clear area is defined in various standards as an elliptical area whose major axis is twice the measurement distance and whose minor axis is the square root of 3 times the measurement distance. Experience has shown over the decades that these dimensions are too small. Doubling them has been tried and even that has been shown to have its weaknesses, especially when the OATS is surrounded by a chain link fence for security. The picture below shows a 30 meter OATS built in 1989 for Tandem Computers Incorporated near Hollister, California. The clear area is at least twice the required dimensions for a 30 meter site and takes a considerable amount of land. This site is no longer in operation, but it illustrates the point. The building on the ground plane was constructed of RF transparent material and covered the turntable. All utilities were run underground, including the air conditioning ducts with the air conditioning units being installed outside the clear area. The site was never utilized at a measurement distance of 30 meters, so it was a superb 10 meter site.



Figure 2 - A typical open area test site (OATS).

A significant weakness of the OATS facility is that in addition to measuring the emissions from the EUT it is a great facility to measure all the local RF ambient signals from

broadcast and communications services, as well. If these signals are strong enough they will totally mask the emissions from the EUT that you were trying to measure. As a result, for best operation an OATS must be located in a very remote area. And this is no guarantee that the ambient level will remain low. Apple Computer had a great OATS near Pescadero, California that had a very low ambient when it was built in the 1980s. Apple ultimately stopped using the facility when the local ambient signals grew to the point where operation was no longer possible and moved totally to 10 meter SACs near their development facilities.

Regardless of whether measurement are taken at an OATS or in a SAC, the block diagram of the test set-up remains the same. Emissions from the EUT are measured using an antenna for the appropriate frequency range, a pre-amplifier (if necessary) and a measuring receiver. Measurements are taken with the antenna in both the vertical and horizontal polarities. See the block diagram in *Figure 3*.

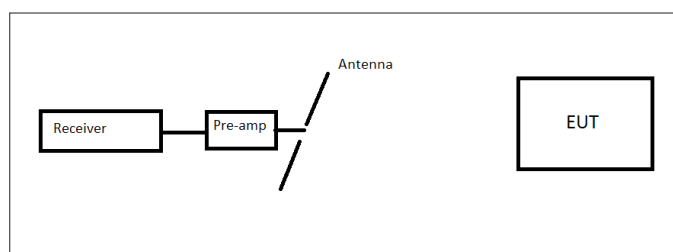

Figure 3 - General test setup for radiated emissions testing.

The need for height scans is shown by the diagram in *Figure 4*. The objective is to adjust the antenna height until the direct and reflected signals are maximized. An example of an antenna mast for this purpose is shown in the photograph above of the Tandem 30 meter OATS (*Figure 2*).

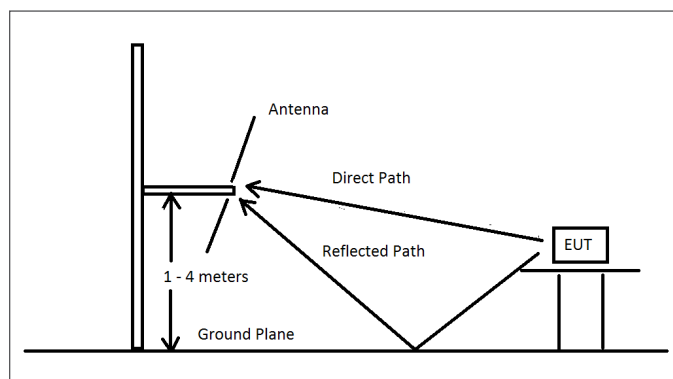

Figure 4 - Diagram showing the direct and reflected waves. The antenna height is adjusted to maximize the measurement.

Emissions tests are required in many countries around the world. Immunity testing of commercial products is required in a smaller number of countries, but these are some major countries, so a manufacturer must be aware of them.

COMMERCIAL IMMUNITY TESTS

Commercial immunity testing typically covers the following types of tests:

1. Electrostatic Discharge (ESD)

There are two types of ESD tests – contact discharge and air discharge. In the contact discharge test the tip of the ESD simulator is placed on the test point of the EUT and the discharge is initiated. The discharge occurs inside the simulator and these tests are fairly repeatable. In the air discharge test the simulator is charged to the specified voltage and brought into contact with the EUT. The discharge, if it occurs, happens before contact is made jumping the air gap between the tip of the simulator and the EUT. How large this gap is depends of the atmospheric pressure, temperature, angle of approach, and relative humidity. It can also depend on how fast the operator approaches the EUT with the ESD gun. Air discharge testing is not as repeatable, but it simulates a different ESD event. Both types of tests are typically required. For computer equipment CISPR 24 requires a contact discharge test at 4 kV and air discharge tests up to 8 kV. Tests are typically performed using the equipment and procedures called out in IEC 61000-4-2. The EUT is allowed to react to the test, but it must self-recover after the test. A classic example is a computer playing music over a speaker. You hear a POP! in the speaker when the ESD event occurs, but the music keeps playing afterwards. This is considered a pass. If the music stopped and required operator intervention to re-start, that would be considered a failure.

2. Radiated electric field immunity

This tests the immunity of the EUT to nearby radio transmitters. The frequency range of 80 MHz to 1 GHz is typically tested, although newer standards have tests required as high as 6 GHz. This test is performed in a fully anechoic chamber or a SAC with removable absorbers placed on the floor. Signal levels are used that would annoy the neighbors and cause the local regulators to issue fines, so a shielded environment is a necessity. The current requirements in IEC 61000-4-3 (a commonly used basic standard) call for the E-field to be uniform to within certain requirements before the EUT is brought into the test volume. Four sides of the EUT are typically evaluated. The EUT typically must continue to operate through the test as though nothing was happening to it or must self-recover with no loss of data to be considered a pass.

3. Electrical Fast Transients

This test introduces a series of rapid pulses into the EUT through the power and any signal lines that could exceed 3 meters in length. Like ESD testing, the EUT must operate after the test without operator intervention, but may react to the test as it occurs, so long as the system self-recovers with no loss of data. IEC 61000-4-4 calls out the test equipment and procedures for this test.

4. Electric Surge

This test simulates what happens on the power input to the EUT when there is a nearby lightning strike. High energy surges are applied to the EUT line input. IEC 61000-4-5 details the test equipment and procedures for performing surge testing.

5. Conducted RF

In commercial standards the breakpoint between conducted RF and radiated RF immunity testing is typically 80 MHz. Generating uniform fields much below 80 MHz is difficult. As a result, below that frequency RF energy is typically injected onto cables connected to the EUT. An example of a block diagram for such a test is shown in *Figure 5*. The 6 dB attenuator is placed as close to the Coupling Decoupling Network (CDN) as possible. While this isn't clearly shown in IEC 61000-4-6, the reason for placing it as close to the CDN as possible is that it provides a matching impedance to the transmission line, maximizing power transfer to the CDN, whose input impedance is not precisely known. Otherwise, you may be throwing away half the power you paid to generate.

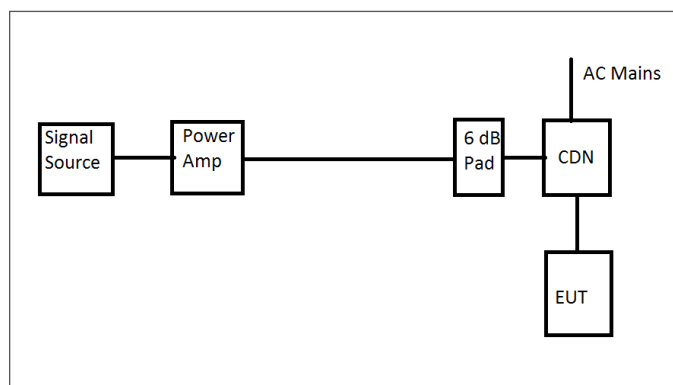

Figure 5 – Typical test setup for the conducted immunity test.

The typical frequency range for conducted RF immunity testing of commercial equipment is 150 kHz to 80 MHz.

6. Power Frequency Magnetic Fields

This test is run for products which might reasonably be expected to have immunity problems with power frequency magnetic fields. Such products, as called out in CISPR 24 for example, might include Cathode Ray Tube (CRT) displays, magnetic field sensors and Hall devices. The EUT is placed in the middle of a large coil of wire through which a power frequency current flows. The current level to generate the

specified field level (for example, 1 Amp/meter in CISPR 24) is run through the coil and the EUT is checked for proper operation. All three axes are tested. Most products do not require this test, but it is included in the product family standards. IEC 62000-4-8 details how to perform this test.

7. Dips and dropouts

This test is designed to simulate real world examples of momentary input power voltage fluctuations. In the case of CISPR 24 (and CISPR 35) there are three tests that are performed, typically by a computerized power source. The first is a >95% voltage reduction for one half cycle of the incoming power. The voltage change occurs at the zero crossover point on the power waveform. This simply means that one half cycle of the incoming power to the EUT is chopped off. The EUT is allowed to react, but must self-recover without operator intervention. The second test is a 30% reduction (70% residual voltage) for one half second (25 cycles at 50 Hz or 30 cycles at 60 Hz) - a short brown-out. Again, the EUT may react, but must self-recover. The third commonly used test is a >95% reduction in input voltage for 5 seconds. It's like the power cord was pulled out of the wall socket for 5 seconds and then plugged back in. Obviously, unless the EUT has a built in battery or UPS, it will crash. As long as function can be restored by the operator in accordance with the instructions and no data protected by battery back-up is lost or damaged, the EUT passes this test. IEC 61000-4-11 provides the details on how these tests are to be run.

The test levels utilized in commercial immunity tests are designed to provide a reasonable level of certainty that the product will operate in its intended environment. They do not represent the worst case that a product might experience in the field, but they have been shown over the years to be adequate. Indeed, most products exhibit higher levels of immunity that required when tested to their breaking point and the design features used to meet the emissions requirements typically are adequate for providing this level of immunity.

DEVELOPING AN IN-HOUSE EMC TROUBLESHOOTING AND PRE-COMPLIANCE TEST LAB

Kenneth Wyatt

Wyatt Technical Services LLC
ken@emc-seminars.com

While investing in your own full in-house EMC test laboratory may seem difficult to justify, most companies should be able to afford to implement some level of pre-compliance testing capability. Outside compliance test labs can cost upwards of \$2,000 per day. The advantage of being able to perform some of the key tests in-house is that you can quickly determine whether your product is anywhere close to passing. Identifying "red flags" or problem areas early allows more cost-effective implementation of fixes. Waiting until the end of a product development cycle to determine EMC compliance is always very risky and usually expensive in time and money.

As a consultant, I frequently run into clients that have worked for weeks or months to beat down a radiated emissions problem by repeatedly cycling between their R&D lab and third-party compliance test lab. This is very frustrating for both the designers and their management. By performing some very quick and simple tests, you can identify failures, narrow down the root cause, and try various fixes well before taking the product in for full compliance testing.



DEVELOPING AN IN-HOUSE EMC TROUBLESHOOTING AND PRE-COMPLIANCE TEST LAB

DEVELOPING YOUR OWN EMI TEST LAB

So, what's involved in developing a basic EMC pre-compliance test lab? It's not nearly as expensive as you might think. For example, there are only four common test failures I run into regularly: radiated emissions (RE) is always the number one issue, followed by radiated immunity (RI), electrostatic discharge (ESD), and conducted emissions (CE). With few exceptions and assuming a good power line and I/O port filtering, many of the line- or I/O port-related immunity tests are lower risk and usually pass OK. However, some low-end Asian power supplies do have inadequate or non-existent line filtering, and so I've added the CE test, which is relatively easy to perform.

Briefly, radiated emissions measures the radiated E-fields emanating from the product, equipment, or system under test. There are worldwide limits on how much these emissions can be, depending on the environment the equipment I designed to work in.

Radiated immunity is a measure of how much external E-fields the product or system can tolerate from external sources like broadcast, cellular phones or two-way radios, etc. Electrostatic discharge is a test to see how immune the product or system is to external static discharges, usually from operators touching keypads or touch screens.

Conducted emissions is a measure of the broadband and narrow band noise conducting out the line cord from switch-mode power supplies.

EMI TROUBLESHOOTING VERSUS PRE-COMPLIANCE TESTING

There's a difference between general troubleshooting and pre-compliance testing. General troubleshooting is usually performed with a set of probes and a spectrum analyzer. The goal is to identify sources of harmonic energy and determine fixes that reduce the harmonic amplitudes. Here, we're mainly looking for relative changes.

Pre-compliance testing, on the other hand, attempts to duplicate the way the compliance tests are run to the best ability possible and to compare with actual test limits.

Here is a list of basic equipment required for these four tests:

1. **Radiated Emissions** — While an oscilloscope is very useful for determining rise times and ringing, a spectrum analyzer is really the desired instrument for most EMI troubleshooting and measurement. In addition, you'll want a set of near-field probes, a current probe, a calibrated (or uncalibrated — see *Note 1*) EMI antenna, and possibly a 20 dB gain broadband preamplifier to boost the signal from the probes.
2. **Radiated Immunity** — You'll need an RF generator that can tune the required frequency band and possibly

an RF amplifier to boost the signal level.

3. **Electrostatic Discharge** — You'll need an ESD simulator.
4. **Conducted Emissions** — Conducted emissions testing is performed according to CISPR 11 or 22 and requires a LISN between the source of AC line (or DC) voltage and the product under test. A spectrum analyzer is connected to the 50-Ohm port and the conducted RF noise voltage is displayed on the analyzer. Different model LISNs are made for either AC or DC supply voltage.

All the above equipment may be purchased on the used market. There is also a new category of "affordable" equipment, as well as lab-quality level equipment, depending on your budget. Generally, most pre-compliance testing does not require very expensive equipment, but you also need to factor in some niceties, such as real-time spectrum analysis for signals that may only appear infrequently or signals, such as wireless communications, that may not display clearly on low-cost swept analyzers. More on this is described in our 2016 *Real-Time Spectrum Analyzer Guide* (*Reference 1*). In addition, there may be important reasons to stick with higher-end lab-quality equipment with their higher performance.

RADIATED EMISSIONS

Because radiated emissions is usually the most frequent test failure, most of your investment should be focused on this test. Even so, there is a wide range of test investment choices. For example, a basic troubleshooting test setup I use frequently, is merely an uncalibrated receiving antenna positioned at one end of a workbench, connected to a small bench top spectrum analyzer. The product under test is positioned at the other end of the work bench (*Figure 1*). Cables are attached to the EUT and various troubleshooting techniques are used to help pinpoint product design issues.

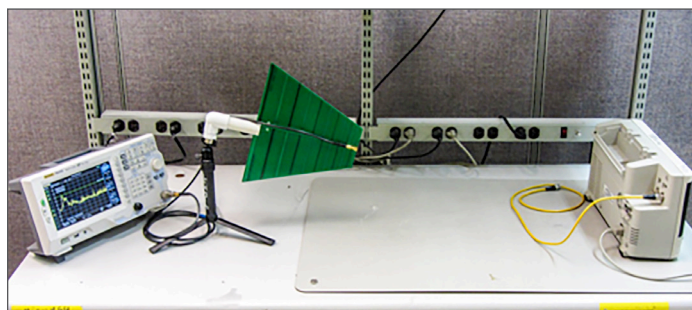

Figure 1. A typical troubleshooting test setup for radiated emissions.

Pre-compliance testing, requires a calibrated EMI antenna positioned either 1 m or (better) 3 m away from the product under test. This way, you'll be able to compare the emissions with actual test limits. The test may be set up in any area large enough and far away from other equipment that could interfere with the testing. Sometimes a parking lot is used. I've more often used a large conference room (*Figure 2*). The one big issue in testing outside a shielded semi-anechoic chamber is you must deal with ambient signals — that

is transmissions from broadcast radio/TV, cellular transmissions, and two-way radio.



Figure 2. An example of a 3 m pre-compliance test set up in a large conference room. Note the DIY turntable for helping maximize emissions.

RADIATED IMMUNITY

Radiated immunity testing may also be performed using simple troubleshooting techniques or in a shielded semi-anechoic chamber. Most of what I call “pre-compliance” testing is really just using an RF generator and near field probes, or a small Family Radio Service (FRS) license-free walkie-talkie. If the product under test can pass these simple tests, then it's also likely it will pass the formal tests at test levels of 3 V/m or 10 V/m (for commercial/industrial products). Military RI testing will more likely require much higher test levels that fall outside the scope of these simple bench top level tests.

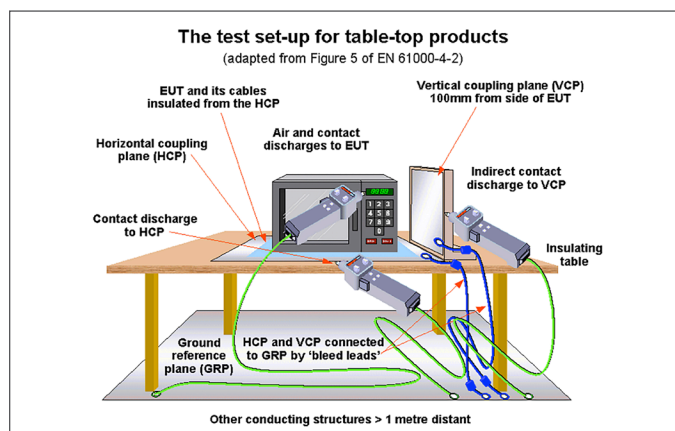

Figure 3. The ESD test setup according to IEC 6100-4-2. Image, courtesy Keith Armstrong.

ELECTROSTATIC DISCHARGE

Electrostatic discharge pre-compliance testing can be performed on a work bench, but it's much better to duplicate the test table and ground planes as specified in the IEC 61000-4-2 test standard. This requires certain table dimensions with a conductive table surface and ground plane of certain size underneath. (Figure 3).

CONDUCTED EMISSIONS

Conducted emissions testing is performed according to CIS-PR 11 or 22 and requires a LISN between the source of AC

line (or DC) voltage and the product under test. A spectrum analyzer is connected to the 50-Ohm port and the conducted RF noise voltage is displayed on the analyzer. Different model LISNs are made for either AC or DC supply voltage.

SUMMARY

Investing in the equipment required to test and troubleshoot the most likely things that cause test failures is usually well worth the expense. Repeatedly moving back and forth between the R&D lab and compliance test lab can consume weeks of time and lead to project cost overruns.

NOTE ON THE USE OF EXTERNAL ANTENNAS

Note that there are two distinct goals when using external EMI antennas:

1. Relative troubleshooting, where you know areas of failing frequencies and need to reduce their amplitudes. A calibrated antenna is not required, as only relative changes are important. The antenna also does not necessarily need to be tuned to the frequency of the harmonics. Almost any “hunk of metal” connected to the spectrum analyzer should work. The important thing is that harmonic content from the EUT should be easily visible.
2. Pre-compliance testing, where you wish to duplicate the test setup as used by the compliance test lab. That is, setting up a calibrated antenna 3 m or 10 m away from the product or system under test and determining in advance whether you're passing or failing.

REFERENCES

1. Real-Time Spectrum Analyzer Guide - <https://interferencetechnology.com/wp-content/uploads/2016/10/2016-IT-Real-Time-Spectrum-Analyzer-Guide.pdf>
2. List of recommended equipment - http://www.emc-seminars.com/EMI_Troubleshooting_Equipment_List-Wyatt.pdf

Wyatt Technical Services, LLC

EMC Seminars & Design



REDUCE DELAYS - Let us help you with:

- EMC Design
- Troubleshooting
- Design Reviews
- Seminars

Essential EMC Books - Amazon!

Contact information:

Kenneth Wyatt
ken@emc-seminars.com
www.emc-seminars.com

Book info on my web site...



MILITARY RELATED DOCUMENTS & STANDARDS

The following references are not intended to be all inclusive, but rather a representation of available sources of additional information and point of contacts.

-
- MIL-HDBK-235-1D** Military Operational Electromagnetic Environment Profiles Part 1D General Guidance, 03 April 2018.
- MIL-HDBK-237D** Electromagnetic Environmental Effects and Spectrum Certification Guidance for the Acquisition Process, 20 May 2005. (Notice 1 Validation 04 April 2013)
- MIL-HDBK-240A** Hazards of Electromagnetic Radiation to Ordnance (HERO) Test Guide, 10 Mar 2011.
- MIL-HDBK-263B** Electrostatic Discharge Control Handbook for Protection of Electrical and Electronic Parts, Assemblies and Equipment (Excluding Electrically Initiated Explosive Devices), 31 Jul 1994.
- MIL-HDBK-274A** Electrical Grounding for Aircraft Safety, 14 Nov 2011. (Notice 1 Validation 16 August 2016)
- MIL-HDBK-335** Management and Design Guidance Electromagnetic Radiation Hardness for Air Launched Ordnance Systems, Notice 4, 08 Jul 2008. (Notice 5 Cancellation 01 August 2013)
- MIL-HDBK-419A** Grounding, Bonding, and Shielding for Electronic Equipment and Facilities, 29 Dec 1987. (Notice 1 Validation 20 February 2014)
- MIL-HDBK-454B** General Guidelines for Electronic Equipment, 15 Apr 2007. (Notice 1 Validation 12 December 2012)
- MIL-HDBK-1195**, Radio Frequency Shielded Enclosures, 30 Sep 1988.
- MIL-HDBK-2036** Preparation of Electronic Equipment Specifications, 1 November 1999
- MIL-STD-188-124B** Grounding, Bonding, and Shielding for Common Long Haul/Tactical Communications-Electronics Facilities and Equipment, 4 April 2013.
- MIL-STD-220C** Test Method Standard Method of Insertion Loss Measurement, 14 May 2009. (Notice 2 Validation 08 October 2019)
- MIL-STD-331D** Fuze and Fuze Components, Environmental and Performance Tests for, 31 May, 2017.
- MIL-STD-449D** Radio Frequency Spectrum Characteristics, Measurement of, 22 Feb 1973. (Notice 1 18 May 1976, Notice 2 Validation 04 April 2013)
- MIL-STD-461F** Requirements for the Control of Electromagnetic Interference Characteristics of Subsystems and Equipment, 10 Dec 2007.
- MIL-STD-461G** Requirements for the Control of Electromagnetic Interference Characteristics of Subsystems and Equipment, 11 Dec 2015.
- MIL-STD-464C** Electromagnetic Environmental Effects Requirements for Systems, 01 Dec 2010. (MIL-STD-464D to be released in 2020)
- MIL-STD-704F** Aircraft Electric Power Characteristics, Change Notice 1, 05 December 2016.
- MIL-STD-1275E** Characteristics of 28 Volt DC Power Input to Utilization Equipment in Military Vehicles, 22 March 2013 (MIL-STD-1275F expected release in 2020)
- MIL-STD-1310H** Standard Practice for Shipboard Bonding, Grounding, and Other Techniques for Electromagnetic Compatibility Electromagnetic Pulse (EMP) Mitigation and Safety, 17 Sep 2009. (Notice 1 Validation 12 August 2014)
- MIL-STD-1377** Effectiveness of Cable, Connector, and Weapon Enclosure Shielding and Filters in Precluding Hazards of EM Radiation to Ordnance; Measurement of, 20 Aug 1971.
- MIL-STD-1399 Section 300B** Interface Standard for Shipboard Systems, Electric Power, Alternating Current, Cancelled 25 September 2018.
- MIL-STD-1399 Section 300 Part 2** Medium Voltage Electric Power, Alternating Current, 25 September 2018
- MIL-STD-1541A** Electromagnetic Compatibility Requirements for Space Systems, Cancelled 27 April 2017.

MIL-STD-1542B Electromagnetic Compatibility and Grounding Requirements for Space System Facilities, 15 Nov 1991. MIL-STD-1605 Procedures for Conducting a Shipboard Electromagnetic Interference (EMI) Survey (Surface Ships), 15 Nov, 1991.

MIL-STD-1605A (SH) Procedures for Conducting a Shipboard Electromagnetic Interference (EMI) Survey (Surface Ships), 8 October 2009 (Validation Notice 1, 12 August 2014)

MIL-STD-1686C Electrostatic Discharge Control Program for Protection of Electrical and Electronic Parts, Assemblies, and Equipment (Excluding Electrically Initiated Explosive Devices). 25 Oct 1995.

ADS-37A-PRF Electromagnetic Environmental Effects (E3) Performance and Verification Requirements, 28 May 1996.

DOD-STD-1399 Section 070 Part 1 D.C. Magnetic Field Environment, Notice 1, 30 Nov 1989.

DoDI 3222.03 DoD Electromagnetic Environmental Effects (E3) Program, Change Notice 2, 10 October 2017. DoDD 4650.01 Policy and Procedures for Management and Use of the Electromagnetic Spectrum, 09 Jan 2009.

DoDI 6055.11 Protecting Personnel from Electromagnetic Fields, 19 Aug 2009.

TOP 01-2-511A Electromagnetic Environmental Effects System Testing, 20 November 2013

TOP 01-2-620 High-Altitude Electromagnetic Pulse (HEMP) Testing, 10 November 2011

TOP 01-2-622 Vertical Electromagnetic Pulse Testing, 11 September 2009



AUTOMOTIVE ELECTROMAGNETIC COMPATIBILITY (EMC) STANDARDS

The following list of automotive EMC standards was developed by Dr. Todd Hubing, Professor Emeritus of Clemson University Vehicular Electronics Lab (<https://cecas.clemson.edu/cvel/emc/>). A few of these standards have been made public and are linked below, but many others are considered company confidential and are only available to approved automotive vendors or test equipment manufacturers.

While several standards are linked on this list, an internet search may help locate additional documents that have been made public. Permission to republish has been approved.

CISPR (Automotive Emissions Requirements)	
Document Number	Title
CISPR 12	Vehicles, boats, and internal combustion engine driven devices – Radio disturbance characteristics – Limits and methods of measurement for the protection of receivers except those installed in the vehicle/boat/device itself or in adjacent vehicles/boats/devices
CISPR 25	Radio disturbance characteristics for the protection of receivers used on board vehicles, boats, and on devices – Limits and methods of measurement
ISO (Automotive Immunity Requirements)	
Document Number	Title
ISO 7637-1	Road vehicles – Electrical disturbances from conduction and coupling – Part 1: Definitions and general considerations
ISO 7637-2	Road vehicles – Electrical disturbances from conduction and coupling – Part 2: Electrical transient conduction along supply lines only
ISO 7637-3	Road vehicles – Electrical disturbance by conduction and coupling – Part 3: Vehicles with nominal 12 V or 24 V supply voltage – Electrical transient transmission by capacitive and inductive coupling via lines other than supply lines
ISO/TR 10305-1	Road vehicles – Calibration of electromagnetic field strength measuring devices – Part 1: Devices for measurement of electromagnetic fields at frequencies > 0 Hz
ISO/TR 10305-2	Road vehicles – Calibration of electromagnetic field strength measuring devices – Part 2: IEEE standard for calibration of electromagnetic field sensors and probes, excluding antennas, from 9 kHz to 40 GHz
ISO 10605	Road vehicles – Test methods for electrical disturbances from electrostatic discharge
ISO/TS 14907-1	Road transport and traffic telematics – Electronic fee collection – Test procedures for user and fixed equipment – Part 1: Description of test procedures
ISO/TS 14907-2	Road transport and traffic telematics – Electronic fee collection – Test procedures for user and fixed equipment – Part 2: Conformance test for the onboard unit application interface
ISO/TS 21609	Road vehicles – (EMC) guidelines for installation of aftermarket radio frequency transmitting equipment
ISO 11451-1	Road vehicles – Vehicle test methods for electrical disturbances from narrowband radiated electromagnetic energy – Part 1: General principles and terminology

ISO (Automotive Immunity Requirements) continued	
Document Number	Title
ISO 11451-2	Road vehicles – Vehicle test methods for electrical disturbances from narrowband radiated electromagnetic energy – Part 2: Off-vehicle radiation sources
ISO 11451-3	Road vehicles – Electrical disturbances by narrowband radiated electromagnetic energy – Vehicle test methods – Part 3: On-board transmitter simulation
ISO 11451-4	Road vehicles – Vehicle test methods for electrical disturbances from narrowband radiated electromagnetic energy – Part 4: Bulk current injection (BCI)
ISO 11452-1	Road vehicles – Component test methods for electrical disturbances from narrowband radiated electromagnetic energy – Part 1: General principles and terminology
ISO 11452-2	Road vehicles – Component test methods for electrical disturbances from narrowband radiated electromagnetic energy – Part 2: Absorber-lined shielded enclosure
ISO 11452-3	Road vehicles – Component test methods for electrical disturbances from narrowband radiated electromagnetic energy – Part 3: Transverse electromagnetic mode (TEM) cell
ISO 11452-4	Road vehicles – Component test methods for electrical disturbances from narrowband radiated electromagnetic energy – Part 4: Bulk current injection (BCI)
ISO 11452-5	Road vehicles – Component test methods for electrical disturbances from narrowband radiated electromagnetic energy – Part 5: Stripline
ISO 11452-7	Road vehicles – Component test methods for electrical disturbances from narrowband radiated electromagnetic energy – Part 7: Direct radio frequency (RF) power injection
ISO 11452-8	Road vehicles – Component test methods for electrical disturbances from narrowband radiated electromagnetic energy – Part 8: Immunity to magnetic fields
ISO 11452-10	Road vehicles – Component test methods for electrical disturbances from narrowband radiated electromagnetic energy – Part 10: Immunity to conducted disturbances in the extended audio frequency range
ISO 11452-11	Road vehicles – Component test methods for electrical disturbances from narrowband radiated electromagnetic energy – Part 11: Reverberation chamber
ISO 13766	Earth-moving machinery – Electromagnetic compatibility

SAE (Automotive Emissions and Immunity)	
Document Number	Title
J1113/1	Electromagnetic Compatibility Measurement Procedures and Limits for Components of Vehicles, Boats (Up to 15 M), and Machines (Except Aircraft) (50 Hz to 18 GHz)
J1113/2	Electromagnetic Compatibility Measurement Procedures and Limits for Vehicle Components (Except Aircraft)-Conducted Immunity, 15 Hz to 250 kHz-All Leads
J1113/3	Conducted Immunity, 250 kHz to 400 MHz, Direct Injection of Radio Frequency (RF) Power (Cancelled August 2010)
J1113/4	Immunity to Radiated Electromagnetic Fields-Bulk Current Injection (BCI) Method
J1113/11	Immunity to Conducted Transients on Power Leads
J1113/12	Electrical Interference by Conduction and Coupling - Capacitive and Inductive Coupling via Lines Other than Supply Lines
J1113/13	Electromagnetic Compatibility Measurement Procedure for Vehicle Components - Part 13: Immunity to Electrostatic Discharge
J1113/21	Electromagnetic Compatibility Measurement Procedure for Vehicle Components - Part 21: Immunity to Electromagnetic Fields, 30 MHz to 18 GHz, Absorber-Lined Chamber
J1113/24	Immunity to Radiated Electromagnetic Fields; 10 kHz to 200 MHz-Crawford TEM Cell and 10 kHz to 5 GHz-Wideband TEM Cell (Cancelled August 2010)
J1113/26	Electromagnetic Compatibility Measurement Procedure for Vehicle Components - Immunity to AC Power Line Electric Fields
J1113/27	Electromagnetic Compatibility Measurements Procedure for Vehicle Components - Part 27: Immunity to Radiated Electromagnetic Fields - Mode Stir Reverberation Method
J1113/28	Electromagnetic Compatibility Measurements Procedure for Vehicle Components-Part 28-Immunity to Radiated Electromagnetic Fields-Reverberation Method (Mode Tuning)
J1113/42	Electromagnetic Compatibility-Component Test Procedure-Part 42-Conducted Transient Emissions (Cancelled Dec 2010, Superseded by ISO 7637-2)
J1752/1	Electromagnetic Compatibility Measurement Procedures for Integrated Circuits-Integrated Circuit EMC Measurement Procedures-General and Definition
J1752/2	Measurement of Radiated Emissions from Integrated Circuits - Surface Scan Method (Loop Probe Method) 10 MHz to 3 GHz
J1752/3	Measurement of Radiated Emissions from Integrated Circuits - TEM/Wideband TEM (GTEM) Cell Method; TEM Cell (150 kHz to 1 GHz), Wideband TEM Cell (150 kHz to 8 GHz)
J551/5	Performance Levels and Methods of Measurement of Magnetic and Electric Field Strength from Electric Vehicles, Broadband, 9 kHz To 30 MHz
J551/11	Vehicle Electromagnetic Immunity-Off-Vehicle Source (Cancelled March 2010)

SAE (Automotive Emissions and Immunity) continued	
Document Number	Title
J551/12	Vehicle Electromagnetic Immunity-On-Board Transmitter Simulation (Cancelled August 2009)
J551/13	Vehicle Electromagnetic Immunity-Bulk Current Injection (Cancelled August 2009)
J551/15	Vehicle Electromagnetic Immunity-Electrostatic Discharge (ESD)
J551/16	Electromagnetic Immunity - Off-Vehicle Source (Reverberation Chamber Method) - Part 16 - Immunity to Radiated Electromagnetic Fields
J551/17	Vehicle Electromagnetic Immunity - Power Line Magnetic Fields
J1812	Function Performance Status Classification for EMC Immunity Testing
J2628	Characterization-Conducted Immunity
J2556	Radiated Emissions (RE) Narrowband Data Analysis-Power Spectral Density (PSD)
GM	
Document Number	Title
GMW3091	General Specification for Vehicles, Electromagnetic Compatibility (EMC)-Engl; Revision H; Supersedes GMI 12559 R and GMI 12559 V
GMW3097	General Specification for Electrical/Electronic Components and Subsystems, Electromagnetic Compatibility-Engl; Revision H; Supersedes GMW12559, GMW3100, GMW12002R AND GMW12002V
GMW3103	General Specification for Electrical/Electronic Components and Subsystems, Electromagnetic Compatibility Global EMC Component/Subsystem Validation Acceptance Process-Engl; Revision F; Contains Color; Replaces GMW12003, GMW12004 and GMW3106
Ford	
Document Number	Title
EMC-CS-2009.1	Component EMC Specification EMC-CS-2009.1
FORD F-2	Electrical and Electronics System Engineering
FORD WSF-M22P5-A1	Printed Circuit Boards, PTF, Double Sided, Flexible
Daimler AG	
Document Number	Title
DC-10614	EMC Performance Requirements - Components
DC-10615	Electrical System Performance Requirements for Electrical and Electronic Components
DC-11224	EMC Performance Requirements - Components
DC-11225	EMC Supplemental Information and Alternative Component Requirements

Other Automotive Manufacturers	
Audi TL 82466	Electrostatic Discharge
BMW 600 13.0	Electric- / Electronic components in cars
BMW GS 95002	Electromagnetic Compatibility (EMC) Requirements and Tests
BMW GS 95003-2	Electric- / Electronic assemblies in motor vehicles
Chrysler PF 9326	Electrical electronic modules and motors
FIAT 9.90110	Electric and electronic devices for motor vehicles
Freightliner 49-00085	EMC Requirements
Honda 3838Z-SSAA-L000	Noise Simulation Test
Honda 3982Z-SDA-0030	Battery Simulation Test
Hyundai/Kia ES 39110-00	EMC Requirements
Hyundai/Kia ES-95400-10	Battery Simulation Tests
Hyundai/Kia ES 96100-01	EMC Requirements
IVECO 16-2103	EMC Requirements
Lotus 17.39.01	Lotus Engineering Standard: Electromagnetic Compatibility
Mack Trucks 606GS15	EMC Requirements
MAN 3285	EMC Requirements
Mazda MES PW 67600	Automobile parts standard (electronic devices)
Mercedes A 211 000 42 99	Instruction specification of test method for E/E-components
Mercedes AV EMV	Electric aggregate and electronics in cars
Mercedes MBN 10284-2	EMC requirements and tests of E/E-systems (component test procedures)
Mercedes MBN 22100-2	Electric / electronic elements, devices in trucks
Mitsubishi ES-X82010	General specification of environment tests on automotive electronic equipment
Nissan 28401 NDS02	EMC requirements (instruction concerning vehicle and electrical ...)
Nissan 28400 NDS03	Low frequency surge resistance of electronic parts
Nissan 28400 NDS04	Burst and Impulse Waveforms
Nissan 28400 NDS07	Immunity against low frequency surge (induction surge) of electronic parts
Peugeot B217110	Load Dump Pulses
Porsche AV EMC EN	EMC Requirements
PSA B21 7090	EMC Requirements (electric and electronics equipment)
PSA B21 7110	EMC requirements (electric and electronics equipment)
Renault 36.00.400	Physical environment of electrical and electronic equipments
Renault 36.00.808	EMC requirements (cars and electrical / electronic components)
Scania TB1400	EMC Requirements
Scania TB1700	Load Dump Test

Other Automotive Manufacturers	
Smart DE10005B	EMC requirements (electric aggregate and electronics in cars)
Toyota TSC7001G	Engineering standard (electric noise of electronic devices)
Toyota TSC7001G-5.1	Power Supply Voltage Characteristic Test
Toyota TSC7001G-5.2	Field Decay Test
Toyota TSC7001G-5.3	Floating Ground Test
Toyota TSC7001G-5.4	Induction Noise Resistance
Toyota TSC7001G-5.5.3	Load Dump Test-1
Toyota TSC7001G-5.5.4	Load Dump Test-2
Toyota TSC7001G-5.5.5	Load Dump Test-3
Toyota TSC7001G-5.6	Over Voltage Test
Toyota TSC7001G-5.7.3	Ignition Pulse (Battery Waveforms) Test-1
Toyota TSC7001G-5.7.4	Ignition Pulse (Battery Waveforms) Test-2
Toyota TSC7001G-5.8	Reverse Voltage
Toyota TSC7006G-4.4.2	Wide Band-Width Antenna Nearby Test (0.4 to 2 GHz)
Toyota TSC7006G-4.4.3	Radio Equipment Antenna nearby Test (28 MHz ...)
Toyota TSC7006G-4.4.4	Mobile Phone Antenna Nearby Test (835 MHz ...)
Toyota TSC7018G	Static Electricity Test
Toyota TSC7025G-5	TEM Cell Test (1 to 400 MHz)
Toyota TSC7025G-6	Free Field Immunity Test (20 MHz to 1 GHz AM, 0.8 to 2 GHz PM)
Toyota TSC7025G-7	Strip Line Test (20 - 400 MHz)
Toyota TSC7026G-3.4	Narrow Band Emissions
Toyota TSC7203G	Voltage Drop / Micro Drops
Toyota TSC7508G-3.3.1	Conductive Noise in FM and TV Bands
Toyota TSC7508G-3.3.2	Conductive noise in LW, AM and SW Bands
Toyota TSC7508G-3.3.3	Radiated Noise in FM and TV Bands
Toyota TSC7508G-3.3.4	Radiated Noise in AM, SW, and LW Bands
Toyota TSC7203G	Engineering standard (ABS-TRC computers)
Toyota TXC7315G	Electrostatic Discharge (Gap Method)
Visteon ES-XU3F-1316-AA	Electronic Component - Subsystem Electromagnetic Compatibility (EMC) Requirements and Test Procedures
Volvo EMC Requirements	EMC requirements for 12V and 24V systems
Volkswagen VW TL 801 01	Electric and electronic components in cars
Volkswagen VW TL 820 66	Conducted Interference
Volkswagen VW TL 821 66	EMC requirements of electronic components - bulk current injection (BCI)
Volkswagen VW TL 823 66	Coupled Interference on Sensor Cables
Volkswagen VW TL 824 66	Immunity Against Electrostatic Discharge
Volkswagen VW TL 965	Short-Distance Interference Suppression



EMC LIVE 2021 is a series of **FREE**, online learning events designed for and by engineers in the EMC design and testing space. It features five separate one-day events, each focused on one of the most popular EMC areas in the industry:

Mil/Aero EMC | EMC Testing | Automotive EMC
Wireless/5G/IoT EMC | EMC Fundamentals

Attend an EMC LIVE event to learn the latest in EMC standards, equipment, theory, and design straight from the industry thought leaders.

Available Now

- **MILITARY/AEROSPACE EMC** | [WATCH IT HERE](https://emc.live/2021-event/mil-aero/) ▶ <https://emc.live/2021-event/mil-aero/>
- **EMC TESTING** | [WATCH IT HERE](https://emc.live/2021-event/testing/) ▶ <https://emc.live/2021-event/testing/>

Coming Soon

- **AUTOMOTIVE EMC** | [JUNE 8, 2021](#)
- **WIRELESS,5G & IOT EMC** | [SEPTEMBER 21, 2021](#)
- **EMC FUNDAMENTALS** | [NOVEMBER 9, 2021](#)

All for **FREE** | WWW.EMC.LIVE



INTERFERENCE TECHNOLOGY WIRELESS / 5G / IOT



WIRELESS & IoT EMC SUPPLIERS MATRIX

Introduction

There are two main categories of equipment in this handy supplier guide: EMI troubleshooting & measurement equipment and direction finding equipment.

EMI troubleshooting and measurement equipment includes spectrum analyzers, near field probes, current probes, antennas, and other pre-compliance equipment.

Direction finding (or DFing) equipment usually includes specialized portable, mobile, or base station spectrum analyzers with custom antennas and mapping software especially designed for locating interfering sources.

Wireless & IoT EMC Supplier Matrix		Type of Equipment								
Manufacturer	Contact Information - URL	Amplifiers	Antennas	Current Probes	Fixed DF Systems	Mobile DF Systems	Near Field Probes	Portable DF Systems	Pre-Compliance Test	Spectrum Analyzers / Receivers
360Compliance	www.360compliance.co/								X	
Aaronia AG	www.aaronia.com	X	X		X	X		X	X	X
Alaris Antennas	www.alarisantennas.com		X							
Anritsu Company	www.anritsu.com		X							X
Avalon Test Equipment Corp	www.avalontest.com	X	X	X		X	X		X	X
CommsAudit	www.commsaudit.com/products/direction-finding		X		X	X				X
Doppler Systems	www.dopsys.com		X		X	X		X		
The EMC Shop	www.theemcshop.com	X	X	X			X		X	X
Gauss Instruments	www.gauss-instruments.com/en/									X
Intertek	www.intertek.com								X	
Kent Electronics	www.wa5vjb.com		X							

Wireless & IoT EMC Supplier Matrix		Type of Equipment								
Manufacturer	Contact Information - URL	Amplifiers	Antennas	Current Probes	Fixed DF Systems	Mobile DF Systems	Near Field Probes	Portable DF Systems	Pre-Compliance Test	Spectrum Analyzers / Receivers
Keysight Technologies	www.keysight.com/main/home.jsp?cc=US&lc=eng						X		X	X
Morcom International	www.morcom.com/direction_finding_systems.html							X		X
MPB srl	www.gruppompb.uk.com		X	X					X	X
MVG, Inc	www.mvg-world.com/en		X				X		X	
Narda/PMM	www.narda-sts.it/narda/default_en.asp	X	X						X	X
Pearson Electronics	www.pearsonelectronics.com			X						
RDF Antennas	www.rdfantennas.com/bc-121-5.php							X		
RDF Products	www.rdfproducts.com				X	X				X
Rhotheta America	www.rhothetaamerica.com/index.html				X	X		X		
Rigol Technologies	www.rigolna.com			X			X		X	X
R&K Company Limited	www.rk-microwave.com	X								
Rohde & Schwarz USA, Inc.	www.rohde-schwarz.com/us/	X	X	X	X	X	X	X	X	X
Siglent Technologies	www.signlentamerica.com						X			X
Signal Hound	www.signalhound.com			X						X
SPX/TCI	www.spx.com/en/our-businesses/detection-and-measurement/TCI/		X		X	X		X		X
SteppIR Communication Systems	www.steppir.com		X							
TechComm	www.techcommdf.com		X		X	X		X		X
Tektronix	www.tek.com					X	X	X	X	X
Teseq	www.teseq.com/en/index.php	X		X					X	
Thurlby Thandar (AIM-TTi)	www.aimtti.us								X	X
TMD Technologies	www.tmd.co.uk	X								
UST	www.unmannedsystemstechnology.com/company/marshall-radio-telemetry/							X		X

WIRELESS GROUPS & ORGANIZATIONS

MAJOR WIRELESS LINKEDIN GROUPS

- Wireless Telecommunications Worldwide
- Wireless and Telecom Industry Network
- Cellular, Wireless & Mobile Professionals
- Wireless Communications & Mobile Networks
- 802.11 Wireless Professionals
- Wireless Consultant
- Telecom & Wireless World

WIRELESS ASSOCIATIONS AND ORGANIZATIONS

APCO International

<https://www.apcointl.org>

APCO International is the world's oldest and largest organization of public safety communications professionals and supports the largest U.S. membership base of any public safety association. It serves the needs of public safety communications practitioners worldwide — and the welfare of the general public as a whole — by providing complete expertise, professional development, technical assistance, advocacy and outreach.

ATIS

<http://www.atis.org>

In a rapidly changing industry, innovation needs a home. ATIS is a forum where the information and communications technology (ICT) companies convene to find solutions to their most pressing shared challenges.

Bluetooth Special Interest Group

<https://www.bluetooth.com>

Join thousands of the world's most innovative companies already developing and influencing Bluetooth technology.

CTIA - The Wireless Association

<http://www.ctia.org>

CTIA is an international nonprofit membership organization that has represented the wireless communications industry since 1984. The association's members include wireless carriers, device manufacturers, suppliers as well as apps and content companies.

ETSI - European Telecommunications Standards Institute

<http://www.etsi.org>

We produce globally applicable standards for Information & Communications Technologies including fixed, mobile, radio, broadcast, internet, aeronautical, and other areas.

NAB - National Association of Broadcasters

<http://nab.org>

The National Association of Broadcasters is the voice for the nation's radio and television broadcasters. As the premier trade association for broadcasters, NAB advances the interests of our members in federal government, industry and public affairs; improves the quality and profitability of broadcasting; encourages content and technology innovation; and spotlights the important and unique ways stations serve their communities.

Satellite Industry Association

<http://www.sia.org>

The Satellite Industry Association (SIA) is a Washington D.C. based trade association representing the leading global satellite operators, service providers, manufacturers, launch services providers, and ground equipment suppliers.

Telecommunications Industry Association

<http://www.tiaonline.org>

The Telecommunications Industry Association (TIA) is the leading trade association representing the global information and communications technology (ICT) industry through standards development, policy initiatives, business opportunities, market intelligence and networking events. With support from hundreds of members, TIA enhances the business environment for companies involved in telecom, broadband, mobile wireless, information technology, networks, cable, satellite, unified communications, emergency communications, and the greening of technology.

Wireless Infrastructure Association (WIA)

<http://wia.org>

The Wireless Infrastructure Association represents the businesses that develop, build, own, and operate the nation's wireless infrastructure.

Wireless Innovation Forum

<http://www.wirelessinnovation.org>

WInnForum members are dedicated to advocating for the innovative use of spectrum and advancing radio technologies that support essential or critical communications worldwide. Through events, committee projects, and initiatives the Forum acts as the premier venue for its members to collaborate to achieve these objectives, providing opportunities to network with customers, partners and competitors, educate decision makers, develop and expand markets, and advance relevant technologies.

WIRELESS GROUPS & ORGANIZATIONS

WiMax Forum

<http://wimaxforum.org>

The WiMAX Forum® is an industry-led, not-for-profit organization that certifies and promotes the compatibility and interoperability of broadband wireless products based upon IEEE Standard 802.16. The WiMAX Forum's primary goal is to accelerate the adoption, deployment, and expansion of WiMAX, AeroMACS, and WiGRID technologies across the globe while facilitating roaming agreements, sharing best practices within our membership and certifying products.

ZigBee Alliance

<http://www.zigbee.org>

Our innovative standards are custom-designed by industry experts to meet the specific market needs of businesses and consumers. These market leading standards give product manufacturers a straightforward way to help their customers gain greater control of, and even improve, everyday activities.



USEFUL WIRELESS REFERENCES

(GROUPS, WEBSITES, BOOKS, FORMULAS & TABLES)

WIRELESS WORKING GROUPS

802.11 Working Group

The 802.11 Working Group is responsible for developing wireless LAN standards that provide the basis for Wi-Fi.
<http://grouper.ieee.org/groups/802/11/>

802.15 Working Group

The 802.15 Working Group is responsible for developing wireless PAN standards that provide the basis for Bluetooth and ZigBee.
<http://www.ieee802.org/15/>

802.16 Working Group

The 802.16 Working Group is responsible for developing wireless MAN standards that provide the basis for WiMAX.
<http://grouper.ieee.org/groups/802/16/>

Bluetooth SIG

The Bluetooth SIG is responsible for developing wireless PAN specifications.
<https://www.bluetooth.com>

Cellular Telecommunications and Internet Association (CTIA)

The CTIA represents cellular, personal communication services, mobile radio, and mobile satellite services over wireless WANs for service providers and manufacturers.
<http://www.ctia.org>

Federal Communications Commission (FCC)

The FCC provides regulatory for RF systems in the U.S.
<https://www.fcc.gov>

GSM Association

The GSM Association participates in the development of development of the GSM platform - holds the annual 3GSM World Congress.
<http://www.gsmworld.com>

Wi-Fi Alliance

The Wi-Fi Alliance develops wireless LAN ("Wi-Fi") specifications based on IEEE 802.11 standards and provides compliance testing of Wi-Fi products.
<http://www.wi-fi.org>

WiMAX Forum

The WiMAX Forum develops wireless MAN standards based on IEEE 802.16 standards and provides compliance testing of WiMAX products.
<http://wimaxforum.org>

ZigBee Alliance

The ZigBee Alliance develops standards for low-power wireless monitoring and control products.
<http://www.zigbee.org>

USEFUL WEBSITES

ARRL RFI Information

<http://www.arrl.org/radio-frequency-interference-rfi>

Jim Brown has several very good articles

on RFI, including: A Ham's Guide to RFI, Ferrites, Baluns, and Audio Interfacing.
www.audiosystemsgroup.com

FCC

<http://www.fcc.gov>

FCC, Interference with Radio, TV and Telephone Signals

<http://www.fcc.gov/guides/interference-defining-source>

IWCE Urgent Communications

<http://urgentcomm.com> has multiple articles on RFI

Jackman, Robin, Measure Interference in Crowded Spectrum, Microwaves & RF Magazine, Sept. 2014.

<http://mwrf.com/test-measurement-analyzers/measure-interference-crowded-spectrum>

RFI Services (Marv Loftness) has some good information on RFI hunting techniques

www.rfiservices.com

TJ Nelson, Identifying Source of Radio Interference Around the Home, 10/2007

<http://randombio.com/interference.html>

USEFUL BOOKS

The RFI Book (3rd edition)

Gruber, Michael
ARRL, 2010.

AC Power Interference Handbook (2nd edition)

Loftness, Marv
Percival Publishing, 2001.

Transmitter Hunting: Radio Direction Finding Simplified

Moell, Joseph and Curlee, Thomas
TAB Books, 1987.

USEFUL WIRELESS REFERENCES

(GROUPS, WEBSITES, BOOKS, FORMULAS & TABLES)

USEFUL BOOKS (CONTINUED)

Interference Handbook

Nelson, William
Radio Publications, 1981.

Electromagnetic Compatibility Engineering

Ott, Henry W.
John Wiley & Sons, 2009.

Platform Interference in Wireless Systems - Models, Measurement, and Mitigation

Slattery, Kevin, and Skinner, Harry
Newnes, 2008.

Spectrum and Network Measurements, (2nd Edition)

Witte, Robert
SciTech Publishing, 2014.

Radio Frequency Interference (RFI) Pocket Guide

Wyatt and Gruber
SciTech Publishing, 2015.

USEFUL FORMULAS AND REFERENCE TABLES

E-Field Levels versus Transmitter Pout			
Pout (W)	V/m at 1m	V/m at 3m	V/m at 10m
1	5.5	1.8	0.6
5	12.3	4.1	1.2
10	17.4	5.8	1.7
25	27.5	9.2	2.8
50	38.9	13.0	3.9
100	55.0	18.3	5.5
1000	173.9	58.0	17.4

Assuming the antenna gain is numerically 1, or isotropic, and the measurement is in the far field and greater than 100 MHz.

Using Decibels (dB)

The decibel is always a ratio...

- Gain = P_{out}/P_{in} , where P = power
- Gain(dB) = $10\log(P_{out}/P_{in})$, where P = power
- Gain(dB) = $20\log(V_{out}/V_{in})$, where V = voltage
- Gain(dB) = $20\log(I_{out}/I_{in})$, where I = current

Power Ratios

3 dB = double (or half) the power

10 dB = 10X (or /10) the power

Voltage/Current Ratios

6 dB = double (or half) the voltage/current

20 dB = 10X (or /10) the voltage/current

Multiplying power by a factor of 2 corresponds to a 3 dB increase in power. This also corresponds to a 6 dB increase in voltage or current.

Commonly Used Power Ratios (dB)		
Ratio	Power	Voltage or Current
0.1	-10 dB	-20 dB
0.2	-7.0 dB	-14.0 dB
0.3	-5.2 dB	-10.5 dB
0.5	-3.0 dB	-6.0 dB
1	0 dB	0 dB
2	3.0 dB	6.0 dB
3	4.8 dB	9.5 dB
5	7.0 dB	14.0 dB
7	8.5 dB	16.9 dB
8	9.0 dB	18.1 dB
9	9.5 dB	19.1 dB
10	10 dB	20 dB
20	13.0 dB	26.0 dB
30	14.8 dB	29.5 dB
50	17.0 dB	34.0 dB
100	20 dB	40 dB
1,000	30 dB	60 dB
1,000,000	60 dB	120 dB

Multiplying power by a factor of 10 corresponds to a 10 dB increase in power. Multiplying a voltage or current by 10 is a 20 dB increase. Dividing by a factor of 10 corresponds to a 10 dB reduction in power, or 20 dB for voltage and current.

USEFUL WIRELESS REFERENCES

(LINKS & WHITEPAPERS)

COMMON WIRELESS FREQUENCY BANDS (LINKS)

GSM Bands:

https://en.wikipedia.org/wiki/GSM_frequency_bands

UMTS Bands:

https://en.wikipedia.org/wiki/UMTS_frequency_bands

LTE Bands:

https://en.wikipedia.org/wiki/LTE_frequency_bands

MMDS:

https://en.wikipedia.org/wiki/Multichannel_Multipoint_Distribution_Service

V Band (40 to 75 GHz):

https://en.wikipedia.org/wiki/V_band

DECT and DECT 6.0

(wireless phones and baby monitors):

https://en.wikipedia.org/wiki/Digital_Enhanced_Cordless_Telecommunications

Comparison of wireless internet standards:

https://en.wikipedia.org/wiki/Comparison_of_mobile_phone_standards

Wi-Fi Protocols (From Intel):

<http://www.intel.com/content/www/us/en/support/network-and-i-o/wireless-networking/000005725.html>

LINKS TO MANUFACTURER'S WHITE PAPERS

VIDEO / Handheld Interference Hunting for Network Operators (Rohde & Schwarz):

https://www.rohde-schwarz.com/us/solutions/wireless-communications/gsm_gprs_edge_evo_vamos/webinars-videos/video-handheld-interference-hunting_229255.html

Interference Hunting With The R&S FSH (Rohde & Schwarz):

https://www.rohde-schwarz.com/us/applications/interference-hunting-with-r-s-fsh-application-note_56280-77764.html

Interference Hunting / Part 1 (Tektronix):

<http://www.tek.com/blog/interference-hunting-part-1-4-get-insight-you-need-see-interference-crowded-spectrum>

Interference Hunting / Part 2 (Tektronix):

<https://in.tek.com/blog/interference-hunting-part-2-4-how-often-interference-happening>

Interference Hunting / Part 3 (Tektronix):

<http://www.tek.com/blog/interference-hunting-part-3-4-use-mask-search-automatically-discover-when-interference-happenin>

Interference Hunting / Part 4 (Tektronix):

<https://www.tek.com/blog/interference-hunting-part-4-4-storing-and-sharing-captures-interference-hunter%E2%80%99s-safety-net>



PC BOARD DESIGN FOR WIRELESS PRODUCTS

Kenneth Wyatt
Wyatt Technical Services, LLC
ken@emc-seminars.com

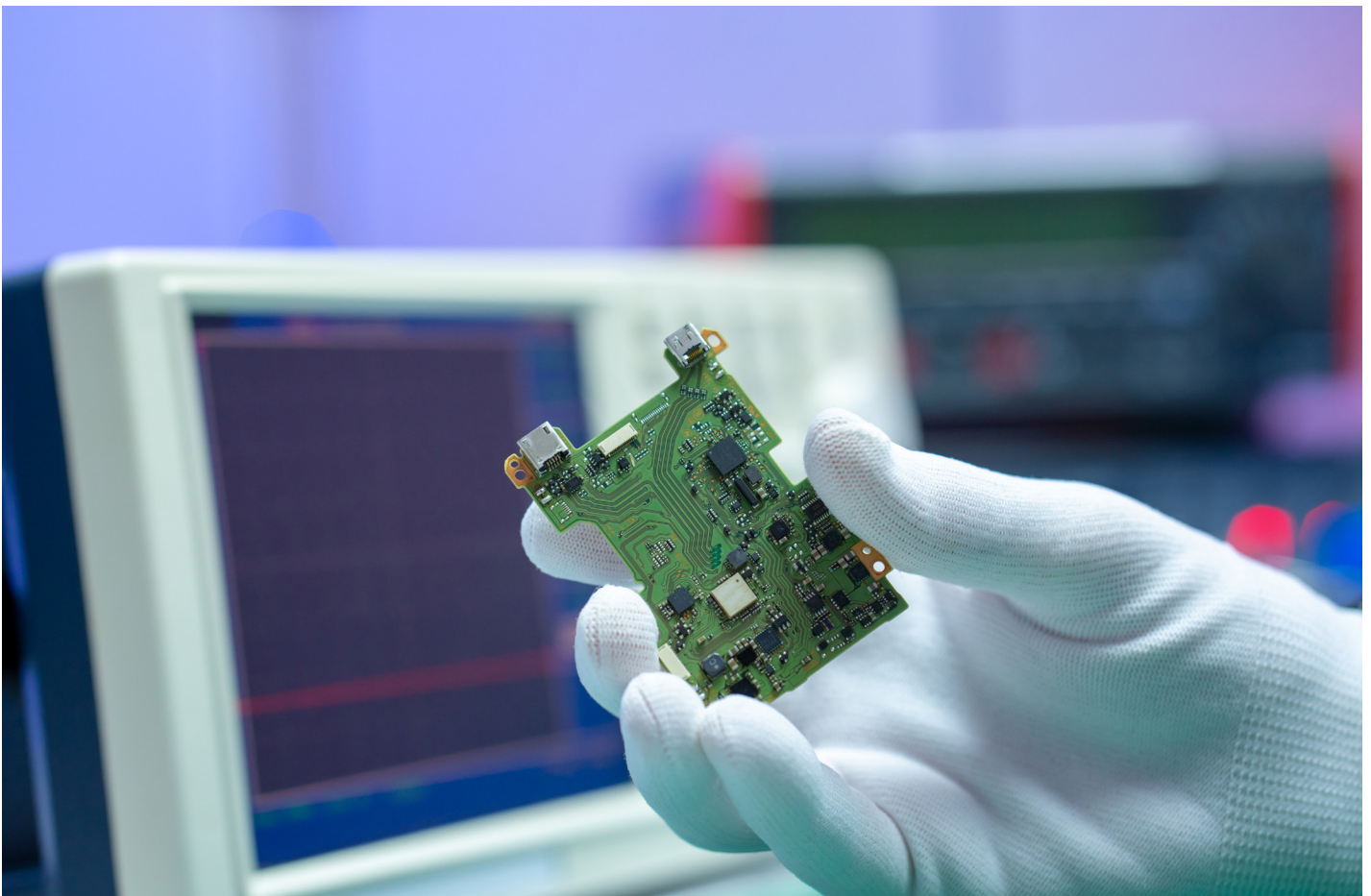

PC BOARD DESIGN FOR WIRELESS PRODUCTS

INTRODUCTION TO SELF-GENERATED EMI

It seems many manufacturers these days are developing products that incorporate wireless technologies — both in new and existing products. Many of these products are using LTE cellular connectivity and designers are finding that the on-board DC-DC converters and processor/memory bus noise are creating enough broadband electromagnetic interference (EMI) that the cellular receiver downlink channels are being desensed (decreased sensitivity) to a point where the product is non-compliant with the cellular provider's sensitivity requirements. Sometimes this broadband EMI even extends up to the GPS bands of 1575.42 MHz affecting navigational performance.

Cellular providers have strict receiver sensitivity requirements and the Total Isotropic Sensitivity (TIS) is one of the tests performed during CTIA compliance. If the receiver is not sensitive enough, the product will not be allowed onto the cellular system (*References 1 and 2*).

WHY PROPER PC BOARD DESIGN IS KEY

One factor that is always key to low-EMI designs is proper PC board design. If high-speed signals are not captured within transmission line structures, common mode current generation, EMI radiated leakage and crosstalk can result. Very often, I find clients use layer stack-up designs suggested in the 1990s for modern wireless designs of today and this is just asking for trouble, with associated schedule delays, debugging, and repeated compliance testing.

In order to understand why proper PC board design is a major key to success, let's first understand how high-speed signals move in circuit boards.

HOW SIGNALS MOVE IN PC BOARDS

I suspect many of us were taught in university or college that electric current was the flow of electrons in copper wires or circuit traces, and that signals travelled at near the speed of light. This is inaccurate. It was also unlikely we

were taught much about how signals propagated in circuit board transmission lines during our fields and waves class.

Before you can understand how signals propagate in PC boards, you must first understand some physics (*References 3 and 4*).

This current flow is partially true, of course, for DC circuits (with exception of the initial battery connection transient). But for AC (or RF) circuits or for the switching transients from switch mode power supplies, we need to understand all connecting wires/traces must now be considered transmission lines.

First, let's consider how capacitors seemingly allow the "flow" of electrons. Referring to *Figure 1*, if we apply a battery to the capacitor, any positive charges applied to the top plate will repel positive charges on the bottom plate, leaving negative charges. If we apply an AC source to the capacitor, it might seem as if the current flows through the dielectric, which is impossible. James Clerk Maxwell called this "displacement current," where positive charges merely displace positive charges on the opposite plate leaving negative charges, and vice versa. This displacement current is defined as dE/dt (changing E-field with time).

Electrons and the positively-charged holes do not travel at near light speed in copper as was implied, but move at about 1 cm/sec, due to the very tight atomic bond of the copper molecules (*Reference 4*). There are certainly clouds of free electrons and holes, but these move slowly from molecule to molecule. This is called conduction current and is what we would measure with an ammeter. Conduction current is related to the tangential component of the B-field, that is the curl $B = J$.

The influence of one electron in the copper molecule to its neighbor (and on down the transmission line) propagates at the speed of the electromagnetic (EM) field in the dielectric material. In other words, jiggle one electron at one end of a microstrip and it jiggles the next, which jiggles the next, and so on, until it jiggles the last one at the load end of the

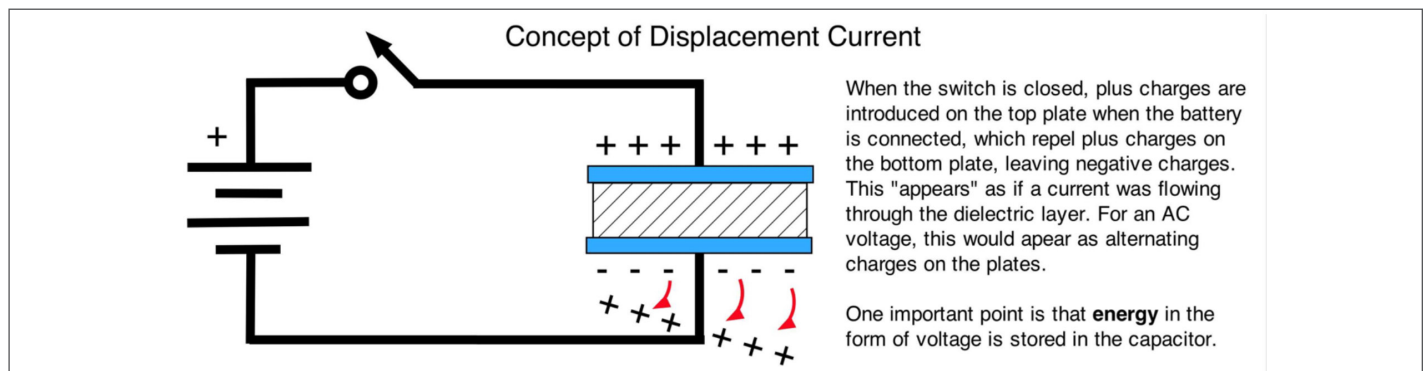

Figure 1: The concept of displacement current through a capacitor.

To construct a transmission line, you need two adjacent pieces of metal that capture or contain the field. Examples include a microstrip over an adjacent GRP or a stripline adjacent to a GRP or a power trace (or plane) adjacent to a GRP. Locating multiple signal layers between power and ground reference planes will lead to real EMI issues for fast signals.

IMPORTANT POINT #1 - In other words, every signal or power trace (routed power) must have an adjacent GRP and all power planes should have an adjacent GRP. Many products end up violating these two rules, with resulting EMI issues.

IMPORTANT POINT #2 - If you break the path of conduction current in the GRP through a gap or slot, we start to get "leakage" of the signal EM field throughout the dielectric space, which leads to edge radiation from the board and cross-coupling to other circuits through via-to-via coupling. This also occurs when we pass a signal through multiple ground reference or power planes if there is no nearby return path adjacent stitching via or stitching capacitor (to connect GRP to power planes). This self-generated EMI can easily conductively couple or radiate into sensitive cellular receivers. Please refer to the video demo explaining why gaps in the GRP are a disaster for EMI (*Reference 6*).

Via penetration: Very often, signals need to be run from the top side to the bottom side (or interior-to-interior layers), relying on vias to get there. If you only need to pass from one side of a GRP to the other, there's no issue, because the electromagnetic field of the signal is contained between a constant metallic transmission line along the entire path (*Figure 4*).

It's only when you need to pass through multiple planes that many designs fail to provide a continuous return path for the electromagnetic wave as it travels through the dielectric space of the board (*Figure 5*).

A lack of transmission-line continuity between the planes (using a stitching via or capacitor), will result in field leakage throughout the dielectric space as the signal tries to find a way back to the source. This field energy will couple to other vias, as well as propagate out as "edge radiation."

If the two planes are GRPs, then you need to merely stitch them together in at least one location near the signal via. This allows field propagation along the entire path. A matrix of ground vias is always a good practice and if they're located very close together (5 mm spacing is good), there's no need to specifically locate one at each penetration.

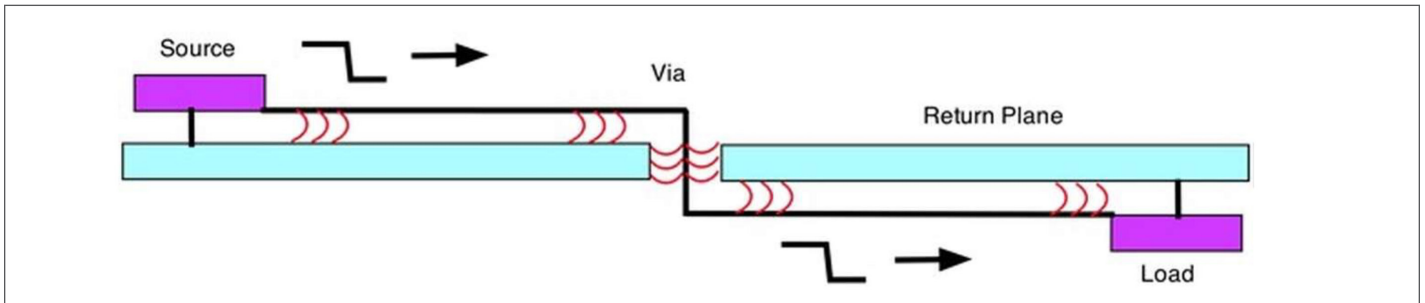

Figure 4. Passing a signal trace through a single GRP allows field propagation along the entire path. The dielectric layer is not shown for clarity and the field propagation is represented by the red "waves."

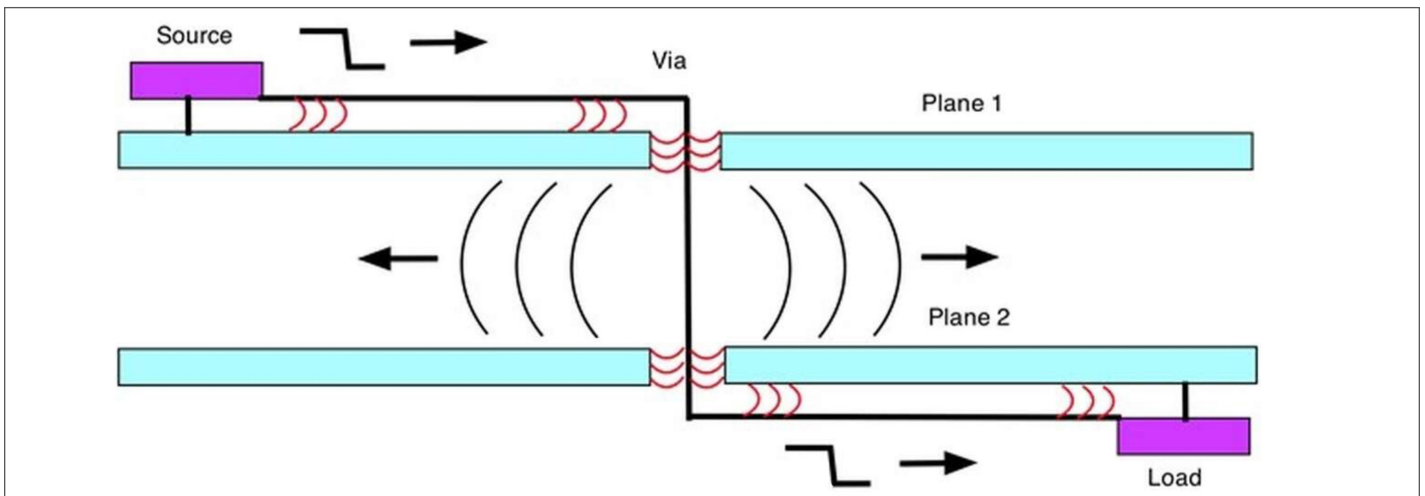

Figure 5. Passing a signal trace through two planes results in field leakage within the dielectric space, unless a defined path for return current is added. The dielectric layer is not shown for clarity and the field propagation is represented by the red "waves."

A challenge presents itself when the two planes are at different potentials, such as a GRP and power, then a stitching capacitor needs to be installed next to the signal via. If there are dozens of signal penetrations on such a board, it may be impractical to add a stitching capacitor for every signal penetration, so that's one reason to locate an even distribution of decoupling/stitching capacitors throughout the board. This will also help reduce "ground bounce" or simultaneous switching noise (SSN).

PROPER BOARD STACK-UP FOR LOW EMI

Observing these two important rules will dictate the layer stack-up. Following are some good and not so good EMI designs. More information on this topic may be found in *References 7 and 8*.

FOUR-LAYER BOARD: POOR (BUT TYPICAL) EXAMPLE

A typical four-layer board design I see often is (top to bottom): Signal - Ground Return Plane - Power Plane - Signal. This worked OK decades ago with relatively slow clock and signal frequencies, but is just asking for EMI issues in today's high frequency wireless technology. Let's show a couple four-layer examples that follow the rules. Note the lack of power planes.

FOUR-LAYER BOARD: GOOD DESIGN 1

Here is an example of a good four-layer board stack-up for improved EMI (*Figure 6*). Instead of a power plane, we use either routed or poured power, along with signals on layers 2 and 3. Thus, each signal/power trace is adjacent to a GRP. Also, it's easy to run simple vias between all layers, so long as the two GRPs are also connected together with a matrix of stitching vias. If you run a row of stitching vias along the perimeter (say, every 5 mm) you form a Faraday cage. This is an excellent option for critical wireless products.

FOUR-LAYER BOARD: GOOD DESIGN 2

If, on the other hand, you'd prefer to have access to the signal and routed/poured power traces, you may simply reverse the layer pairs, such that the two GRP layers are in the middle and the two signal layers are positioned at the top and bottom, with routed power and sufficient decoupling caps, rather than a power plane (*Figure 7*).

For both four-layer designs, you want to run a 5-mm matrix pattern of stitching vias connecting the two GRPs.

For routed or poured power, every digital device will need 2-3 decoupling capacitors per power pin, or tight groupings

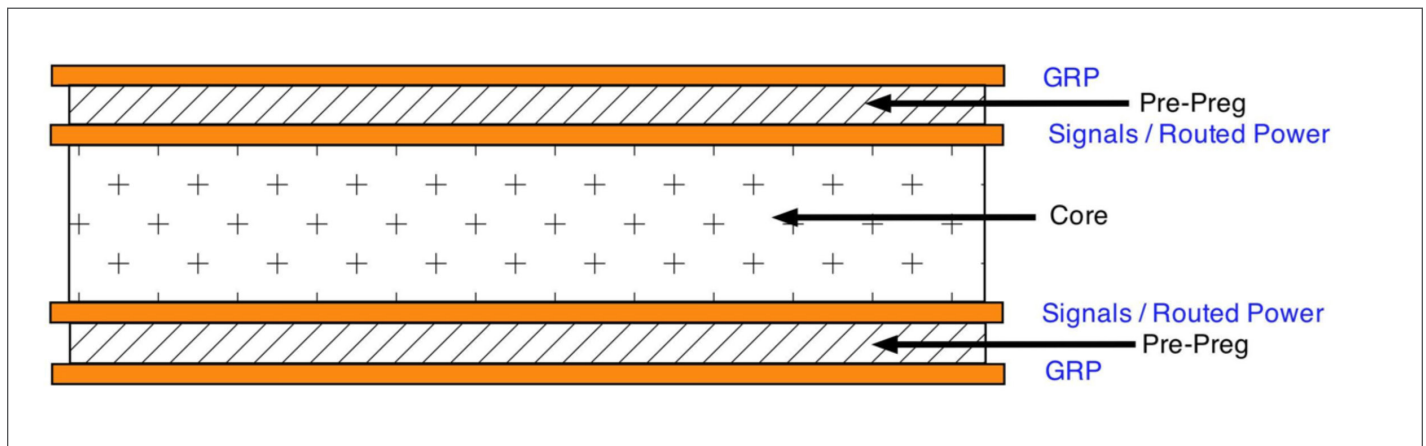

Figure 6: This good four-layer board stack-up for improved EMI keeps the signals and routed power near the ground reference planes.

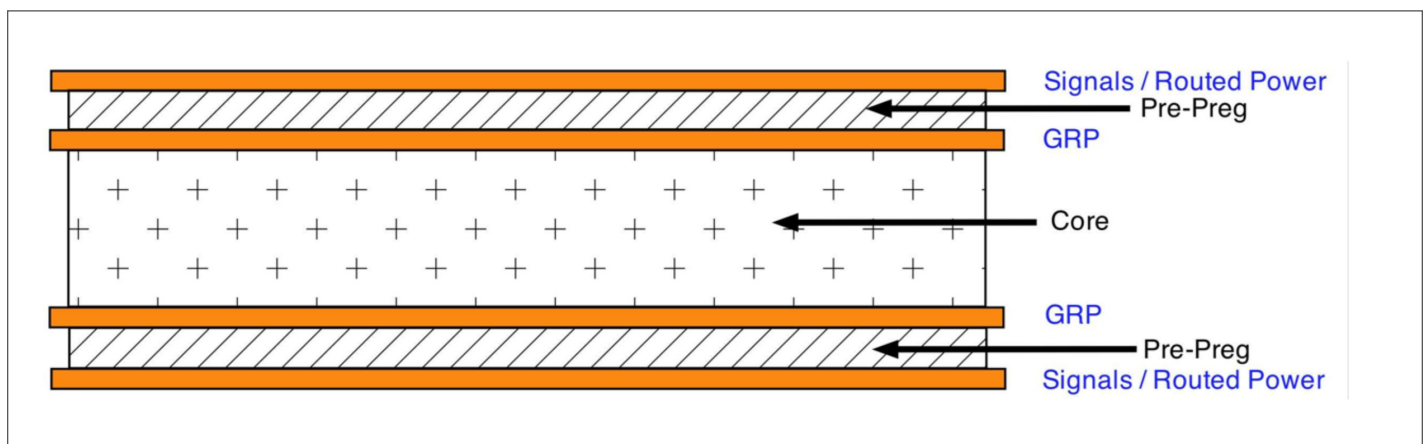
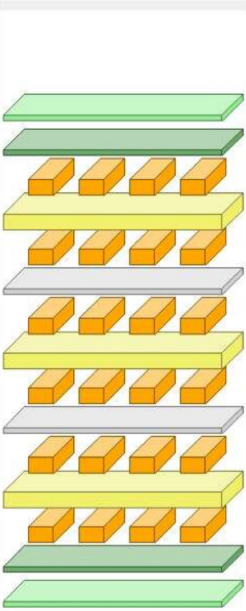

Figure 7: This good four-layer board stack-up for improved EMI places the ground reference planes inside the board.



Layer Name	Type	Material	Thickness (mil)	Dielectric Material	Dielectric Constant
Top Overlay	Overlay				
Top Solder	Solder Mask/Coverlay	Surface Material	0.4	Solder ...	3.5
Top Layer	Signal	Copper	1.4		
Dielectric	Dielectric	Core	7	FR-4	4.2
GND	Signal Gnd	Copper	1.4		
Dielectric 3	Dielectric	Prepreg	15	FR-4	4.2
Signal Layer 1	Signal	Copper	1.4		
Dielectric 5	Dielectric	Core	10	FR-4	4.2
Signal Layer 2	Signal	Copper	1.4		
Dielectric 4	Dielectric	Prepreg	15	FR-4	4.2
Power	Signal Power	Copper	1.4		
Dielectric 1	Dielectric	Core	7	FR-4	4.2
Bottom Layer	Signal	Copper	1.4		
Bottom Solder	Solder Mask/Coverlay	Surface Material	0.4	Solder ...	3.5
Bottom Overlay	Overlay				

Figure 8: A very common, but poor, EMI six-layer stack-up design.

of pins. In addition, rails (typically the main digital voltages) should have wider pours around any high di/dt devices, such as core voltage, drivers, ASICs, motor controllers, processors, etc. This will help serve as your high frequency decoupling.

TYPICAL SIX-LAYER DESIGN: POOR EXAMPLE

One stack-up I frequently see is this six-layer design (*Figure 8*). This probably worked well enough in the a decade or two ago, but like the poor four-layer design, is recipe for EMI disaster. There are two issues with this: the bottom two signal layers are referenced to the power plane and the power and ground return planes are non-adjacent and too far apart for best EMI decoupling.

With few exceptions (some DDR RAM power and signals, for example) currents want to return to their sources, which are referenced to the GRP. Referencing these signals to the power plane is very EMI-risky, because there is no clearly defined return path, except through plane-to-plane capacitance, which in this case, is relatively small. In addition, the indefinite return path can result in field leakage into other areas of the board's dielectric layers. That, in turn, leads to cross-coupling into wireless receivers and other circuitry and radiated EMI.

The second issue occurs when we have the power and GRP separated by two signal layers. Any power distribution network (PDN) transients will cross-couple to any signal traces on layers 3 and 4 within the dielectric layers. You also lose any plane-to-plane capacitance decoupling bene-

fit if these planes are separated by more than 3-4 mils.

EIGHT-LAYER BOARD (GOOD EXAMPLE)

Both the four- and eight-layer board design examples (*Figures 6, 7, and 9*: for *Figures 6 and 7*, see page 116, and for *Figure 9*, see page 119) follow the two fundamental rules (IMPORTANT POINT #1) that preserve good transmission line design and resulting low EMI. In addition, for the eight-layer design, the power and GRP planes are now 4 mils apart, providing good plane-to-plane capacitance. Closer spacing would be even better. For example, a spacing of 1 mil to 3 mils is ideal for minimizing EMI. Multiple GRPs should be stitched together with a 5-mm matrix pattern of vias.

Of course, there are many more iterations on creating proper transmission line pairs between signal and GRP or power and GRP.

PARTITIONING OF CIRCUIT FUNCTIONS

The next most important consideration when laying out the circuitry for your wireless board is partitioning of circuit functions, such as digital, analog, power conversion, RF, and motor control or other high-power circuits.

To avoid signal coupling and crosstalk, you must not allow the various return signals from intermixing within the same dielectric space. Thus, you need to partition major circuit functions. *Figure 10* (see page 119) demonstrates one example of partitioning. Of course, this gets more challenging as board size shrinks. Henry Ott also describes this concept in *Reference 9*.

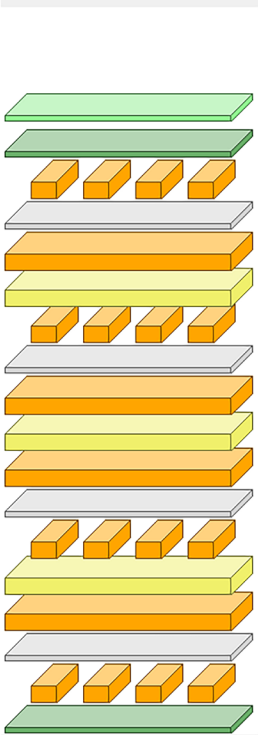

Layer Name	Type	Material	Thickness (mil)	Dielectric Material	Dielectric Constant
TOP SILK	Overlay				
TOP MASK	Solder Mask/Cover	Surface Material	0.04	Solder ...	3.5
Top	Signal	Copper	1.417		
Dielectric1	Dielectric	Prepreg	5	FR-4	4.2
Layer02	Internal Plane Gnd	Copper	0.7		
Dielectric 10	Dielectric	Core	10		4.2
Layer03	Signal	Copper	0.7		
Dielectric 5	Dielectric	Prepreg	10		4.2
Layer04	Internal Plane Gnd	Copper	0.7		
Dielectric 3	Dielectric	Core	4		4.2
Layer05	Internal Plane Pwr	Copper	0.7		
Dielectric 2	Dielectric	Prepreg	10		4.2
Layer06	Signal	Copper	0.7		
Dielectric 8	Dielectric	Core	10		4.2
Layer07	Internal Plane Gnd	Copper	0.7		
Dielectric 9	Dielectric	Prepreg	5		4.2
Bottom	Signal	Copper	1.417		
BOT MASK	Solder Mask/Cover	Surface Material	0.04	Solder ...	3.5

Figure 9: A good EMI stack-up design (8-layer example). All signal layers are referenced to an adjacent GRP, while power is also referenced to an adjacent GRP.

Another way to separate noisy circuits, such as digital and power conversion, from analog and RF circuitry is to locate the digital on the bottom side of the stack-up and the analog and RF modules on the top side. For practical applications, this often assumes at least an eight layer design with one, or more, GRPs near the middle to isolate the top and bottom sides. Great care must be taken to avoid coupling noisy circuitry with sensitive receivers, in the case of wireless designs.

Because low frequency (less than 50 kHz) or audio signal return currents tend to spread out more, that circuitry must be separated from digital, power conversion, or motor controller circuits. Likewise, sensitive RF receiver circuits, such as GPS, cellular, or Wi-Fi devices must also be kept separate from noisy digital, power conversion, or motor controller circuitry.

While *Figure 10* implies routed power, it is very common to use 3.3V power planes under the digital circuitry for good EMI suppression. Power can also be routed as polygons under the appropriate circuit sections.

ADDITIONAL TIPS

Multiple ground vias: It's a good practice to create a matrix of ground vias connecting GRPs together using a spacing of about 5-mm. This will provide multiple return paths for signals penetrating more than one GRP layer. In addition, if you use multiple GRPs, you should design via stitching

all around the periphery of the board to create a Faraday cage for those signal layers in between. This technique is especially useful when incorporating wireless technology in the design.

Ground fills: While it seems to be a fairly common practice to fill in unused areas within each layer with ground fills, besides being unnecessary, they can lead to the issue of the "trace crossing a gap in the return" problem for dense boards where all the transmission line rules may be difficult to achieve. Eric Bogatin explains this a bit more in *Reference 10*.

Routed power versus power planes: The conventional method is to start with one or more (depending on the number of layers) power-ground "cores" and build the signal layers from there, usually equally on each side of the core for best manufacturability. Typically, digital ground return is used for this. Another big advantage is that when spaced very close together (less than 3 mils), the power-ground core becomes a good high-frequency decoupling capacitor. As the number of layers increase, it's often best to locate two or more power-ground cores closer to the top and bottom of the stack-up — generally on layers 2-3 and 6-7 (on eight-layer boards, for example).

CONCLUSION

Most wireless products, especially smaller portable/mobile devices, now require greater care in their overall system

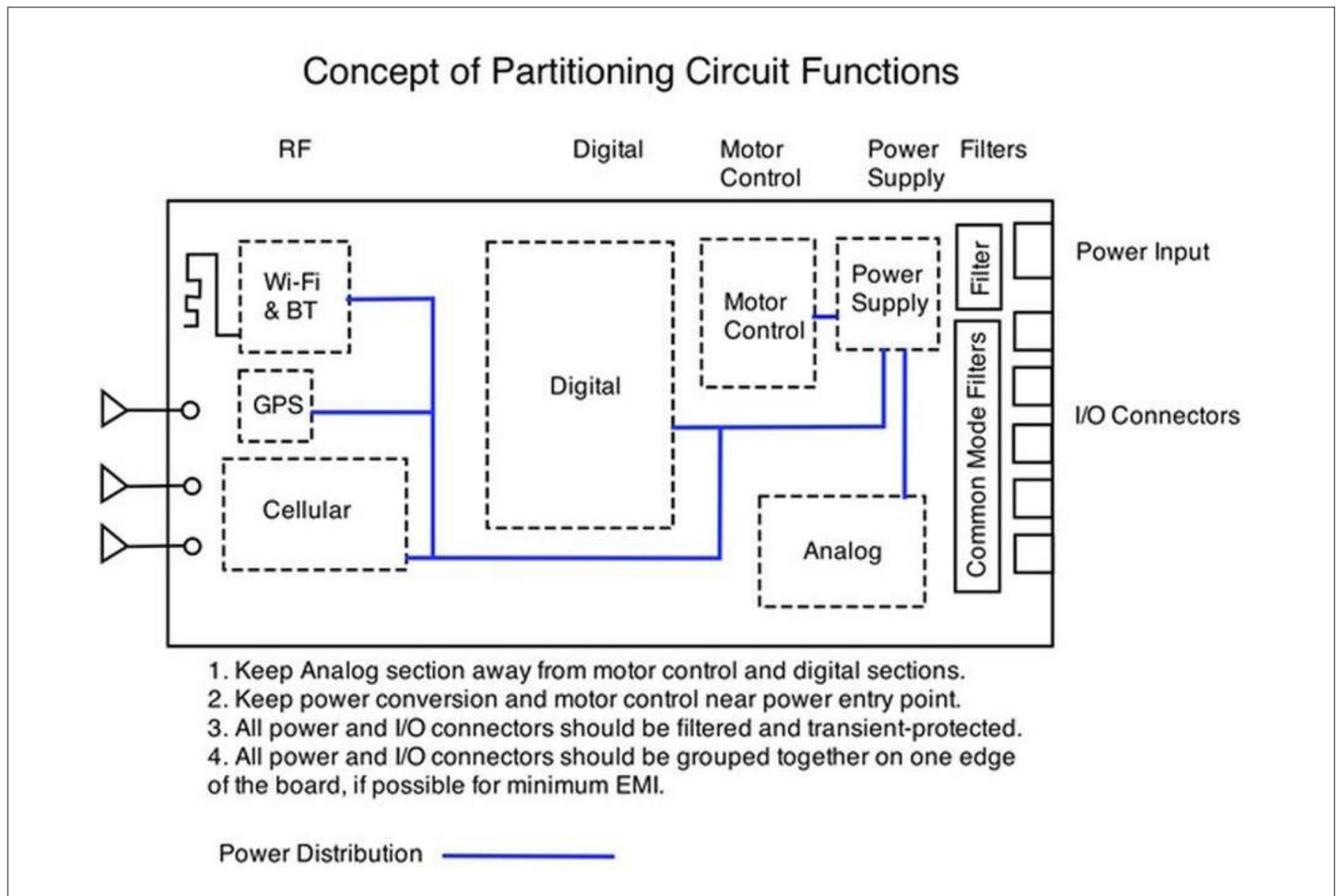

Figure 10: An example of how to partition circuit functions on a board.

design. An important key to low EMI and consequently, optimum performance, is the design of the PC board. You can largely “throw out” the layout rules used in past years, because at the clock and signal speeds used today, all copper traces become transmission lines and require more care to avoid gaps in the signal path where the electromagnetic wave can “leak out” and couple to sensitive circuits.

The important points to remember are that all signal and power networks should now be considered as transmission lines, the signals and power transients travel at about half light speed within the dielectric space, the copper traces “guide” the signals along the GRP, and circuit functions need to be partitioned across the board real estate in order to reduce coupling. Maintaining these guidelines will help assure the lowest EMI and best performing wireless designs.

REFERENCES

1. CTIA, Test Plan for Mobile Station Over the Air Performance: Method of Measurement for Radiated RF Power and Receiver Performance, http://files.ctia.org/pdf/CTIA_OTA_Test_Plan_Rev_3.1.pdf
2. Broadcom, Compliance with TIS and TRP Requirements, <https://www.broadcom.com/collateral/wp/21XX-WP100-R.pdf>
3. Schmitt, Electromagnetics Explained - A Handbook for Wireless/RF, EMC, and High Speed Electronics, Newnes, 2002.
4. Bogatin, Signal Integrity - Simplified (3rd edition), Prentice Hall, 2018.
5. Beeker, Effective PCB Design: Techniques To Improve Performance, https://www.nxp.com/files-static/training_pdf/WBNR_PCBDESIGN.pdf
6. Wyatt, Gaps in Return Planes (video), <https://www.youtube.com/watch?v=L44ITnQgv-o&t=9s>
7. Hartley, Control of Noise, EMI and Signal Integrity in PC Boards (2-day seminar), Rick Hartley Enterprises, managed by <https://www.pcb2day.com>.
8. Morrison, Fast Circuit Boards - Energy Management, Wiley, 2018.
9. Ott, Electromagnetic Compatibility Engineering, Wiley, 2009.
10. Bogatin, Seven Habits of Successful 2-Layer Board Designers (Signal Integrity Journal), <https://www.signalintegrityjournal.com/blogs/12-fundamentals/post/1207-seven-habits-of-successful-2-layer-board-designers>

IDENTIFYING AND LOCATING RADIO FREQUENCY INTERFERENCE (RFI)

Kenneth Wyatt

Wyatt Technical Services, LLC

ken@emc-seminars.com

Introduction

With the plethora of wireless devices, increasing broadcast, communications, and other RF sources all competing for radio spectrum, the chances of radio frequency interference (RFI) will only increase. This article explains how to identify, characterize, and locate typical interfering sources.

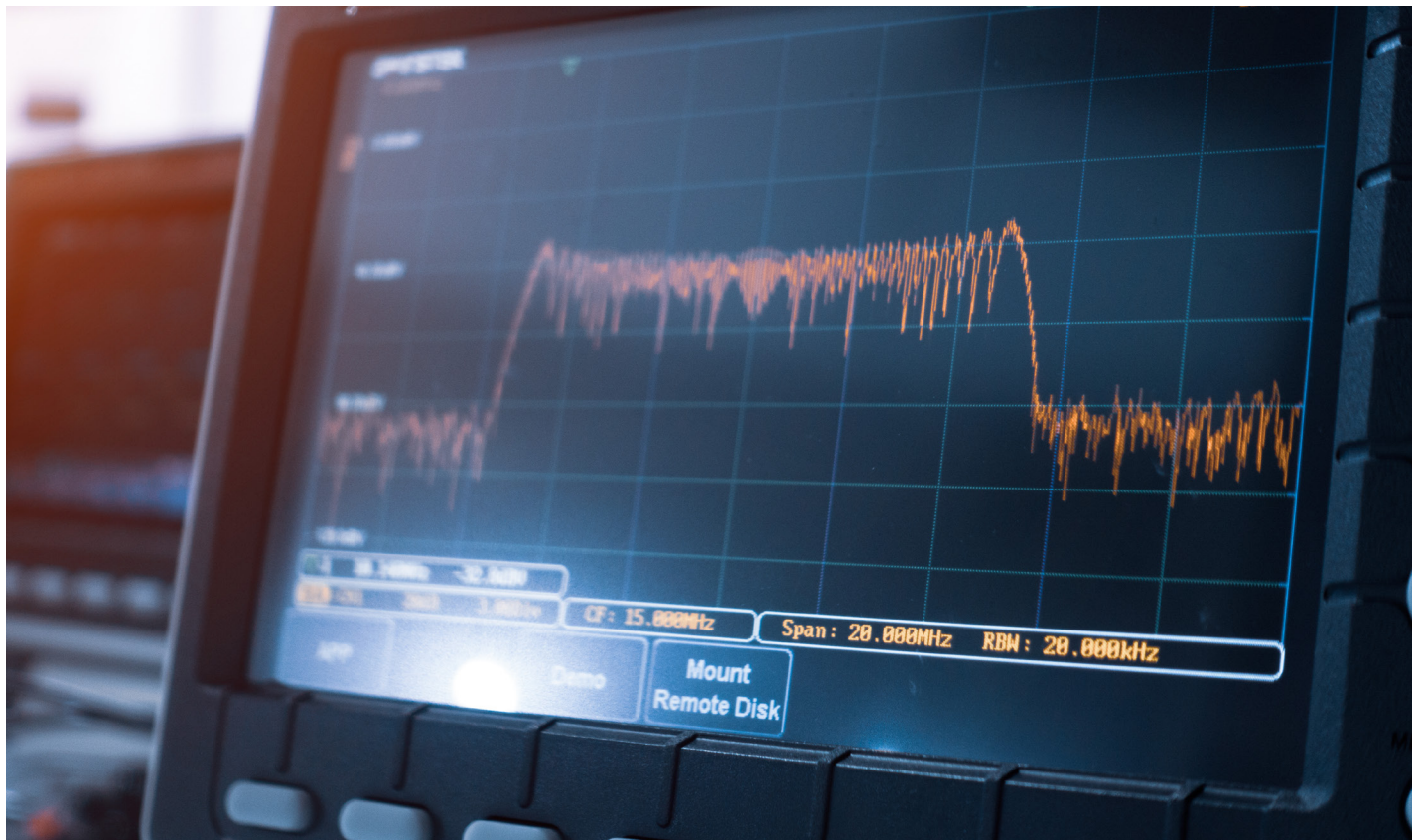

IDENTIFYING AND LOCATING RADIO FREQUENCY INTERFERENCE (RFI)

CATEGORIES OF INTERFERENCE

There are two broad categories of interference; narrow band and broadband (Figure 1).

Narrow Band – this would include continuous wave (CW) or modulated CW signals. Examples might include clock harmonics from digital devices, co-channel transmissions, adjacent-channel transmissions, intermodulation products, etc. On a spectrum analyzer, this would appear to be narrow vertical lines or slightly wider modulated vertical bands associated with specific frequencies.

Broadband – this would primarily include switch-mode power supply harmonics, arcing in overhead power lines (power line noise), wireless digitally-modulated systems (such as Wi-Fi or Bluetooth), or digital television. On a spectrum analyzer, this would appear to be broad ranges of signals or an increase in the noise floor. Power line noise or switch-mode power supplies are the most common sources.

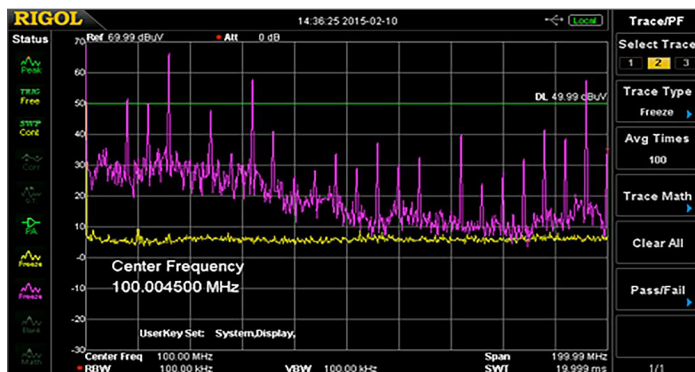

Figure 1: An example spectral plot from 9 kHz to 200 MHz of narrow band harmonics (vertical spikes) riding on top of broadband interference (broad area of increased noise floor). The yellow trace is the baseline system noise.

TYPES OF INTERFERENCE

Some of the most common types of interference are described below.

Co-Channel Interference – more than one transmitter (or digital harmonic) using, or falling into, the same receive channel.

Adjacent-Channel Interference – a transmitter operating on an adjacent frequency whose energy spills over into the desired receive channel.

Intermodulation-Based Interference – occurs when energy from two, or more, transmitters mix together to produce spurious frequencies that land in the desired receive channel. Third-order mixing products are the most common and usually, this occurs from nearby transmitters. An example of potential intermodulation might occur in a strong signal area for FM broadcast.

Fundamental Receiver Overload – this is normally caused by a strong, nearby, transmitter simply overloading the receiver front-end or other circuitry, causing interference or even suppression of the normal received signal. A common example is VHF paging transmitters interfering with receivers.

Power Line Noise (PLN) – This is a relatively common broadband interference problem that is typically caused by arcing on electric power lines and associated utility hardware. It sounds like a harsh raspy buzz in an AM receiver. The interference can extend from very low frequencies below the AM broadcast band, and depending on proximity to the source, into the HF spectrum. If close enough to the source, it can extend up through the UHF spectrum.

Switch-Mode Power Supplies – Switch-mode power supplies are very common and are used for a variety of consumer or commercial products and are a common source of broadband interference. Lighting devices, such as the newer LED-based lights or commercial agricultural “grow” lights, are another strong source of interference.

Other Transmitters – There are several transmitter types that commonly cause RFI:

- **Two-Way or Land Mobile Radio** – Strong interfering FM signals may result in “capture effect”, or over-riding of the desired received signal.
- **Paging Transmitters** – Paging transmitters are generally very powerful FM or digitally modulated transmissions that can overload receiver. Digital paging will sound very raspy, like a power saw or buzzing, and may interfere with a wide range of receive frequencies. Fortunately, most of the VHF paging transmitters moved to the 929/931 MHz frequency pairs, so this is not the issue it once was.
- **Broadcast Transmitters** – Broadcast transmitter interference will have modulation characteristics similar to their broadcasts – AM, FM, video carriers, or digital signals.

Cable Television – Signal leakage from cable television systems will generally occur on their prescribed channel assignments. Many of these channels overlap existing over-the-air radio communications channels. If the leaking signal is a digital channel, interference will be similar to wideband noise (a digital cable channel is almost 6 MHz wide).

Wireless Network Interference – Interference to wireless networks (Wi-Fi, Bluetooth, etc.) is increasingly common, and with the proliferation of mobile, household (IoT), and medical devices incorporating Wi-Fi and other wireless modes, this issue is likely to get worse. More details on wireless interference will be found in the companion article, Wireless Network Interference and Optimization.

LOCATING RFI

SIMPLE DIRECTION FINDING (DFING)

DF Techniques – There are two primary methods for

DFing. (1) “Pan ‘N Scan” where you “pan” a directional antenna and “scan” for the interfering signal, recording the direction on a map, while keeping note of intersecting lines. (2) “Hot and Cold” where an omni-directional antenna is used while watching the signal strength. In this method, the rule of thumb is for every 6 dB change you’ve either doubled or halved the distance to the interfering source. For example, if the signal strength was -30 dBm at one mile from the source, traveling to within a half-mile should read about -24 dBm on the spectrum analyzer.

DF Systems – Radio direction-finding (RDFing) equipment can be installed into a vehicle or used portable. For vehicular use, there are several automated Doppler direction-finding systems available. Some examples include:

- Antenna Authority (mobile, fixed and portable) www.antennaauthorityinc.com
- Doppler Systems (mobile and fixed) www.dopsys.com
- Rohde & Schwarz (mobile, fixed, and portable) <http://www.rohde-schwarz.com>

Step Attenuator – You’ll also find a step attenuator quite valuable during the process of DFing. This allows control over the signal strength indication (and receiver overload) as you approach the interference source. The best models come in steps of 10 dB and have a range of at least 80 dB, or more. Step attenuators may be purchased through electronics distributors, such as DigiKey, etc. Commercial sources would include Narda Microwave, Fairview Microwave, Arrow, and others.

LOCATING POWER LINE INTERFERENCE

For Low Frequency Interference – particularly power line noise (PLN) – the interference path can include radiation due to conducted emissions along power lines. Therefore, when using the “Hot and Cold” method you’ll need to be mindful that the radiated noise will generally follow the route of the power lines, peaking and dipping along the route. The maximum peak usually indicates the actual noise source. As a complication, there may be several noise sources – some possibly long distances away.

Antennas – For simply listening to power line noise, the built-in “loopstick” antenna on an AM broadcast band radio or telescoping antenna on a shortwave radio may work well. However, for tracking down power line noise to the source pole, and typically for DFing other interfering sources, you’ll want to use higher frequencies. A simple directional Yagi, such as the Arrow II 146-4BP (*Figure 17*) with three piece boom (www.arrowantennas.com) can be assembled quickly and attached to a short length of pipe and works well to receive this type of broadband RFI.

Use of VHF Receivers – Whenever possible, you’ll generally want to use VHF or higher frequencies for DFing. The shorter wavelengths not only help in pinpointing the source, they also make smaller handheld antennas more practical.

Signature Analyzers – These are time-domain interference-locating instruments that produce a distinct “signature” of an interfering signal. This would include instruments produced by Radar Engineers (*Figure 2*). They are the best solution for tracking down power line noise and consumer devices that produce repetitive noise bursts with known periodicity.



Figure 2: A signature analyzer from Radar Engineers that tunes from 500 kHz to 1 GHz and which displays an electronic “signature” of a specific interference source. Receivers such as this are used by professional investigators to track down power line noise (photo courtesy, Radar Engineers).

LOCATING NARROW BAND INTERFERENCE

For most narrow band interference sources, such as co-channel, adjacent channel, and intermodulation interference, the recommended tool is the spectrum analyzer, as this allows you to focus on particular frequency channels or bands and see the big picture of what’s occurring. Once the interfering signal is identified, the analyzer can then be used to DF the signal.

USING SPECTRUM ANALYZERS

Spectrum analyzers display frequency versus amplitude of RF signals. They can be helpful in determining the type and frequencies of interfering signals, especially for narrow band interference. There are two types of analyzers; swept-tuned and real time.

Swept-tuned analyzers are based on a superheterodyne principle using a tunable local oscillator and can display a desired bandwidth from start to stop frequencies. They are useful for displaying constant, or near constant, signals, but have trouble capturing brief intermittent signals, due to the lengthy sweep time.

A real-time analyzer samples a portion of the spectrum using digital signal processing techniques to analyze the captured spectrum. They are able to capture brief intermittent signals and are ideal for identifying and locating signals that may not even show up on swept analyzers. Most real-time bandwidths are limited to 27 to 500 MHz, maximum. The Signal Hound BB60C and Tektronix RSA306 are both relatively inexpensive real-time spectrum analyzers that are USB-powered and use a PC for control and display.

One important point to keep in mind regarding the use of spectrum analyzers is that because they have an un-tuned

front end, they are particularly susceptible to high-powered nearby transmitters off frequency from where you may be looking. This can create internal intermodulation products (spurious responses) or erroneous amplitude measurements that are very misleading. When using spectrum analyzers in an “RF rich” environment, it’s important to use bandpass filters or tuned cavities (duplexers, for example) at the frequency of interest.

Spectrum analyzers are also useful to characterize commercial broadcast, wireless, and land mobile communications systems. For wireless or intermittent interference, real-time analyzers work best. If used for tracking PLN, it’s best to place the analyzer in “zero-span” mode to observe the amplitude variation. Placing the analyzer in “Line Sync” may also be helpful.

COMMERCIAL INTERFERENCE HUNTING SYSTEMS

There are several manufacturers of interference hunting or direction-finding systems. I’d like to describe four of these, Aeronia, Narda, Rhode & Schwarz, and Tektronix. As mentioned previously, for intermittent interference (particularly for commercial communications installations) or digitally-modulated signals, a real-time spectrum analyzer is the best tool and has the ability to capture brief, intermittent, signals; some as short as a few microseconds. Examples might include the Aeronia Spectran V5 series. Tektronix RSA-series, or Narda IDA2.

Aeronia – Aeronia not only has the lightest portable system for Dfing, but the biggest and heaviest-looking. Their Spectran V5 Handheld is the smallest real time analyzer. Mapping is not an option on this model, but the larger Spectran V5 XFR PRO is a ruggedized laptop that can use open-source maps and has triangulation features. Aeronia also has a variety of affordable directional antennas and a combination GPS/compass may be mounted on some models.



Figure 3: The Aeronia Spectran V5 handheld real-time analyzer is the smallest self-contained unit and tunes from 9 kHz to 6 GHz. Other models have upper frequencies of 12 and 18 GHz.

Aeronia is also unique in that they’ve developed a drone detection system comprised of a 3D tracking antenna, the model IsoLOG 3D with options from 9 kHz to 40 GHz in 360 degrees. This matches up with their Spectran Command Center with triple LCD screens. See the references for more information on that system.

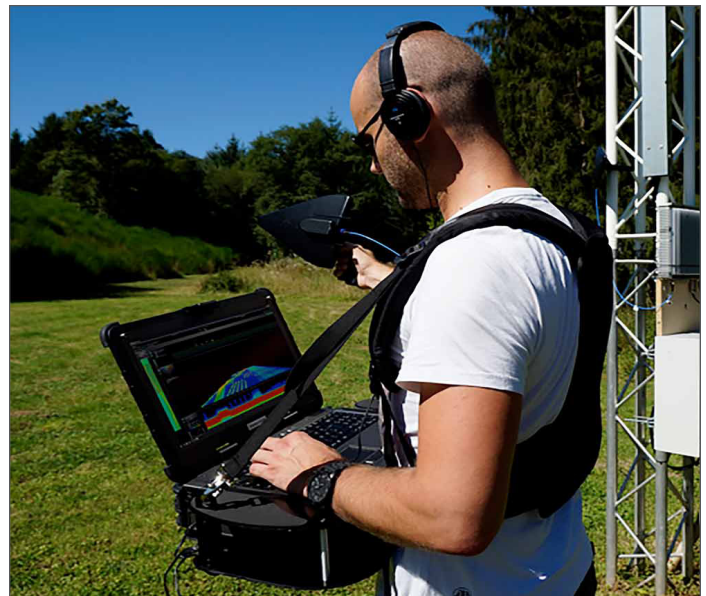

Figure 4: The Aeronia Spectran V5 XFR PRO in the field portable configuration.



Figure 5: The Narda IDA2 spectrum analyzer and interference hunting system. The frequency range is 9 kHz to 6 GHz. Photo, courtesy Narda STS.

Narda Safety Test Solutions – Narda has a similar interference analyzer, the Model IDA2 with a real-time bandwidth of 32 MHz and frequency range of 9 kHz to 6 GHz. There are a variety of directional antennas available with built-in GPS and compass. This system also relies on open-source mapping tools, such as Open Street Maps (<http://www.openstreetmaps.org>). It is battery-operated for easy portable use.

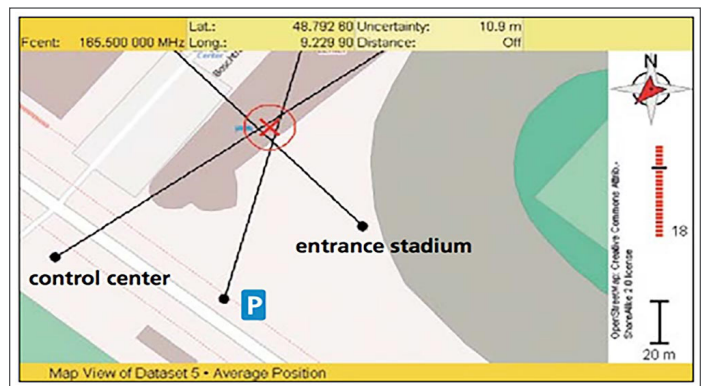

Figure 6: The mapping software with bearing lines drawn showing triangulation of an interference source. Photo, courtesy Narda STS.

Rohde & Schwarz – Rohde & Schwarz has a portable system (Figure 7) that can quickly identify most interference sources and can also use imported mapping feature and GPS/compass in the antenna to triangulate the interfering source. Several fixed, mobile, or portable antennas are available for different frequency bands. This system also relies on open-source mapping tools, such as Open Street Maps (<http://www.openstreetmaps.org>). It is battery-operated for easy portable use.



Figure 7: The Rohde & Schwarz R&S®PR100 custom spectrum analyzer with mapping and triangulation and R&S®HE300 antenna. The R&S® FSH analyzer may also be used. Photo courtesy, Rohde & Schwarz.

Tektronix – Tektronix also has a means of Dfing and mapping with their real time DSA-series spectrum analyzers. The USB-controlled RSA507A is noteworthy due to its built-in battery and portable capability. It also offers 40 MHz real-time bandwidth. By connecting it to a tablet PC, such as the Panasonic Toughpad model FG-Z1 and with the Alaris DR-A0047 antenna, you have a self-contained portable DF hunting tool (Figure 9). This system also relies on open-source mapping tools, such as Open Street Maps (<http://www.openstreetmaps.org>).

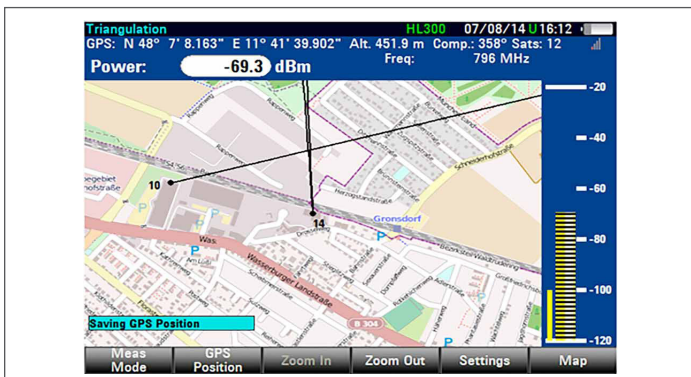

Figure 8: The mapping application for the R&S® FSH analyzer. Photo courtesy, Rohde & Schwarz.



Figure 9: The Tektronix spectrum analyzer with mapping/triangulation and Alaris DR-A0047 antenna. Photo, courtesy Tektronix.

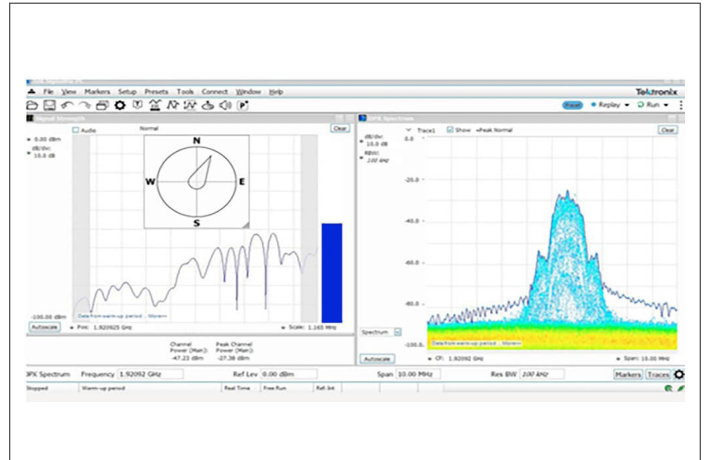

Figure 10: When the SignalVu-PC software with mapping option is connected to one of their RSA-series real time spectrum analyzers and Alaris directional antenna, the compass direction is automatically shown, along with the spectral display of the signal in question. Photo, courtesy Tektronix.

Tektronix provides their SignalVu-PC with Mapping option to help identify and capture interfering signals. The mapping option allows bearing lines to be marked on the map to triangulate the source of interference.

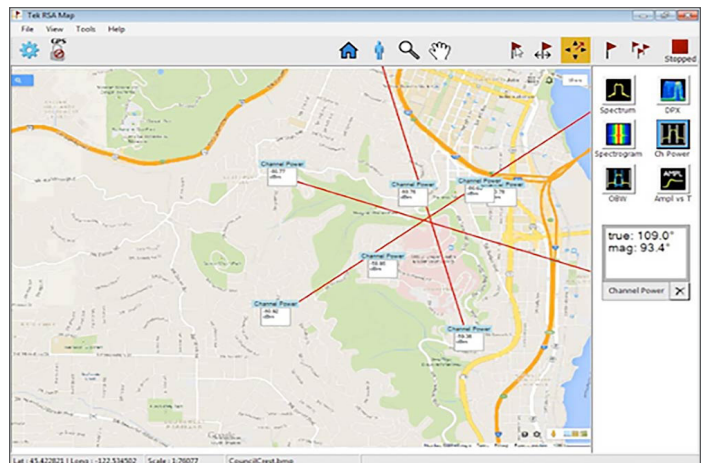

Figure 11: Flipping over to the mapping option of SignalVu-PC, allows you to record bearing lines to the interfering source, with the triangulation showing the approximate location of the source. Photo, courtesy Tektronix.

SUMMARY

With today's increasing use of wireless devices, broadcast, communications, military and other RF sources all competing for radio spectrum, the chances of radio frequency interference (RFI) will only increase. With the proper tools, broadcast and communications engineers are able to quickly identify and eliminate sources of interference as they are detected. The latest real-time spectrum analyzers make the job even more efficient.

MANUFACTURERS MENTIONED

- Aaronia AG <http://www.aaronia.com>
- Narda Safety Test Solutions <https://www.narda-sts.com/en/>
- Radar Engineers <http://www.radarengineers.com>
- Rohde & Schwarz https://www.rohde-schwarz.com/us/home_48230.html
- Tektronix <http://www.tek.com>

REFERENCES

1. Handheld Interference Hunting (R&S video)
2. Automated Interference Hunting in Multipath Environments (R&S video)
3. Advanced Interference Hunting and Emitter Location (R&S)
4. Interference Hunting with R&S@FSH (R&S)
5. Locating A Signal Source (R&S)
6. Interference Hunting (Tektronix)
7. Hunting Interference with the Tektronix RF Scout (Tektronix)
8. Finding, Classifying, and Analyzing Interfering Signals (Tektronix)
9. Clock Radio Disrupts VHF Reception (Narda STS)
10. Analysis of Jamming Systems for Mobile Phone (Narda STS)
11. Drone Detection System (Aaronia)



COST EFFECTIVELY ENSURE ELECTROMAGNETIC COMPATIBILITY IN THE AGE OF IoT

Matthew Maxwell
Rohde & Schwarz

Wireless/RF is ubiquitous, so implement a pre-compliance regimen with off-the-shelf equipment.



COST-EFFECTIVELY ENSURE ELECTROMAGNETIC COMPATIBILITY IN THE AGE OF IoT

Every electronic product has to go through full electromagnetic compatibility (EMC) testing to get the much-coveted stamp of approval from the various regulatory bodies. This has traditionally been a costly undertaking with multiple trips to a distant testing facility, with multiple reworks required to get final approval. In the age of the Internet of Things (IoT), this is not the way to go about it. There is a better approach.

The IoT has changed everything, with wirelessly connected devices creating the opportunity to gather data to perform analytics in order to improve device usability for consumers. For industry, IoT-enabled analytics are improving process, safety, and production outcomes for manufacturing facilities, while opening the possibility of new business models. However, for electronic system and consumer product designers, it has created a number of headaches; some obvious, some more subtle and insidious.

To start with, there's the ubiquitous demand for wireless connectivity, whether it be Wi-Fi, Bluetooth, Zigbee, cellular, or the various flavors of long-range, low-power options such as LoRaWAN, Sigfox, Narrowband-IoT (NB-IoT) or

LTE Cat 1. It's common to have multiple RF interfaces in the same device. This is great for users, but is a nightmare for designers, many of whom are not RF experts. They may have mastered the art of ensuring power supplies no longer interfere with digital circuits, but wireless connectivity adds a whole new dimension of difficulty. From the antenna placement and routing, to the design of high-frequency circuits from 900 MHz to 5 GHz, the difficulties have affected many product delivery schedules, and the problem is only going to get worse with 5G emerging with millimeter-wave operation at 28 GHz and up.

Brave designers will "roll their own" RF circuits, but these tend to be large design teams with high-volume expectations. It seems easy enough, get a good RF integrated circuit (IC) from a reputable vendor, put some shielding around it, place and route the antenna wire, and they're off and running. Maybe. However, a few trends have altered the design landscape and have forced designers to rethink their approach.

The primary influences on designs are smaller form factors, higher integration, and electronic component density per inch squared of printed circuit board (PCB) space, system complexity, higher clock speeds, multiple and distributed power rails with fast-switching transients, LCD emissions as displays get integrated into IoT devices, and faster data

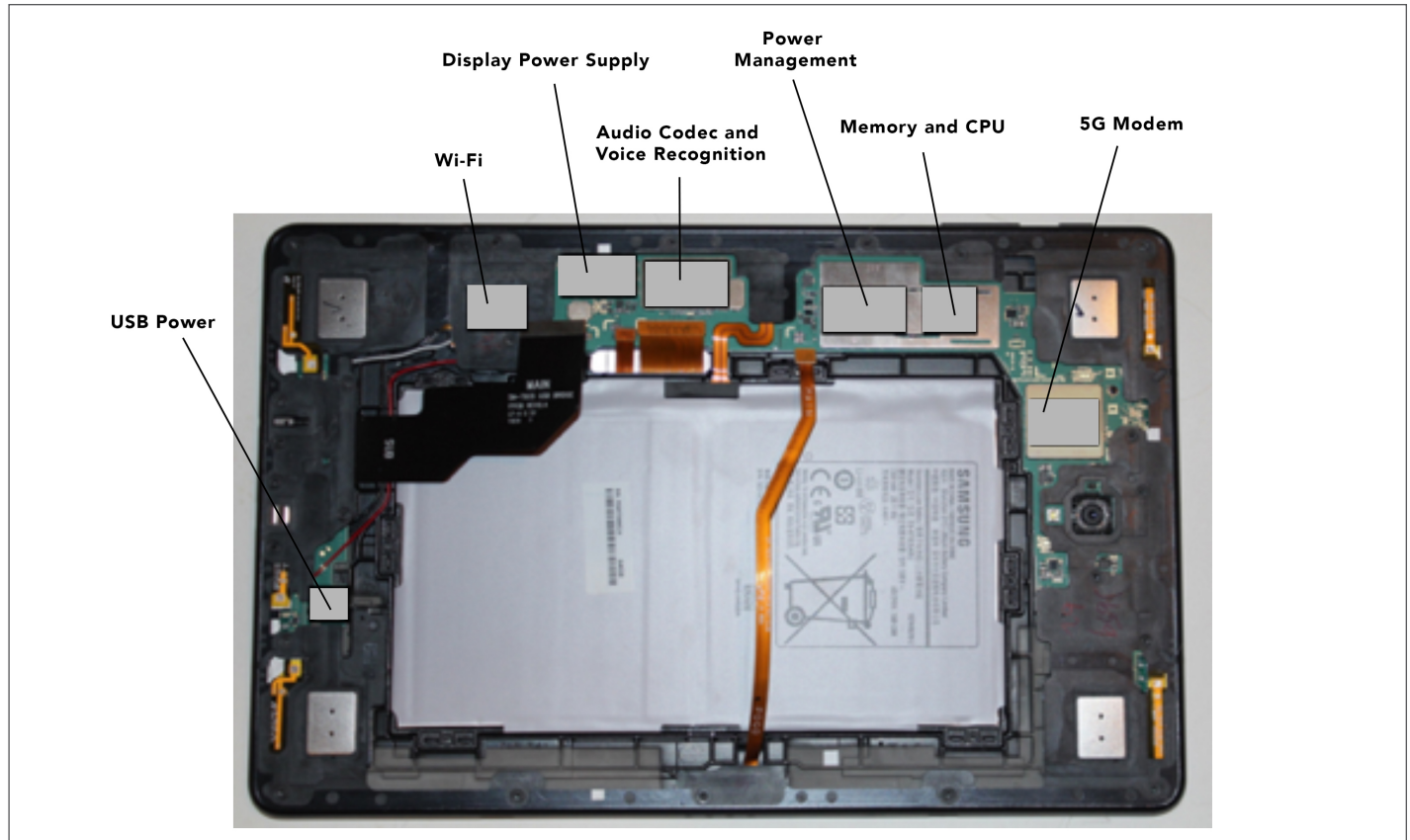

Figure 1: It used to be sufficient to shield a couple of key circuits, but the designers of the Samsung Tab S4 tablet shielded literally every circuit to ensure maximum EMC. The four rectangular silver elements on the corners are speakers, not circuits. (Image Source: Rohde & Schwarz)

transfer rates between central processing unit (CPU) and memory. These are the obvious and classic trends that create interesting challenges that designers actually enjoy solving, though time-to-market pressures and shrinking budgets can be a kill-joy for some, or an added challenge for others.

However, as mentioned, there are two more subtle trends, and these are the ones that are actually causing the most headaches, and the most opportunity for differentiation through innovative approaches to expediting the route to ensuring system EMC.

These trends, which are a direct result of the IoT, are the need to combine power supplies, high-performance digital circuits, and RF interfaces in compact form factors for products that are falling rapidly in price. So much so, that the complexity-to-price ratio is becoming untenable for high-quality, low-cost, smart-home-based systems that are the sweet-spot for IoT devices. Even mobile phone and tablet manufacturers, which have typically been able to charge a premium for higher margins, are getting squeezed as complexity increases and form factors shrink.

To address EMC and its associated electromagnetic interference (EMI) issues, it used to be sufficient to place shielding around key components, such as the RF circuits, to reduce their susceptibility to interference from high-speed digital clock and signal switching harmonics, and to prevent

them from being an interferer. However, as density and complexity has increased, it's now not uncommon to shield literally everything, as in the case of the Samsung Tab S4, *Figure 1*.

The Tab S4 is an extreme example of cutting-edge consumer-level design in terms of density, performance, and complexity, with a price to match (\$649). However, most designs in the IoT space, from white goods and audio streaming systems with built-in voice assistants, to wearables, cost much less, forcing designers to find ways to lower development and test costs.

ACCELERATING EMC TESTING — WHILE LOWERING COST

It's possible to accelerate the design and test cycle when using power-supply and RF modules. These come pre-certified and do save time and resources. However, many designers falsely assume that buying a module means they're home free with respect to national and international compatibility and compliance regulations. Nothing could be further from the truth.

It's true that the RF module may remain fully Bluetooth certified and interoperable, but once the power supply, RF module, antenna, and digital circuits are laid out and connected all regulatory certification bets are off. The full system now needs to be certified to CE, FCC, or CISPR requirements, due to the many and varied interactions be-

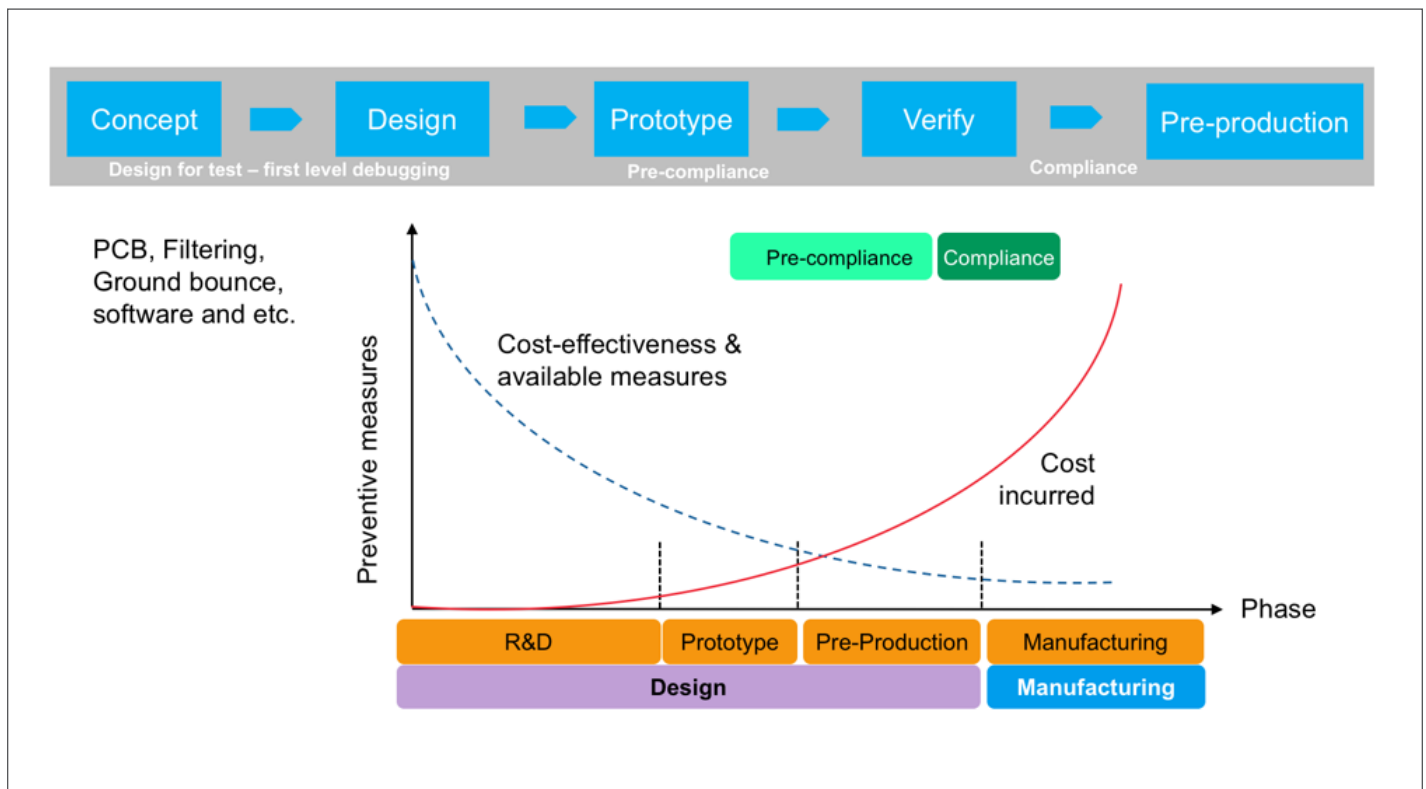

Figure 2: Implementing a regimen of pre-compliance checkpoint tests can greatly increase the chance of completing an IoT design on time and within budget. (Image Source: Rohde & Schwarz)

tween the subsystems. These include load transients, spurious power-supply emissions, various internal and ambient EMI sources, and RF harmonics.

The task for designers is to understand EMC and the effects and sources of EMI, and then performance pre-compliance testing on the system to identify and mitigate any issues — before sending it out to an external lab for certification. Along with the expense of time, the compliance tests themselves can cost up to \$10,000 and up to 90 percent of devices fail the first time around, leading to rework and retesting, sometimes multiple times. The costs add up quickly, especially if the fix requires a full or partial redesign. It's critical to initiate preventative measures, such as design-cycle checkpoints, to help avoid costly project delays, *Figure 2*.

Another important reason to perform pre-compliance testing is to avoid over-design of the device. Often, designers run the risk of adding additional shielding or other precautions, which adds weight, time, power consumption, and direct costs. The goal is to pass the test for full compliance without going overboard.

In order to minimize the chance of multiple rounds of compliance certification and rework, it helps to have some up-front education on EMC and EMI. Combined with off-the-shelf test equipment and some “tricks of the trade,” it's possible to quickly identify and mitigate EMC issues before submitting a system for formal certification.

DEFINING EMC AND IDENTIFYING SOURCES OF EMI

EMC and EMI are often confused, but simply put, EMC is concerned with ensuring various pieces of electrical and electronic equipment can operate in the same electromagnetic environment. It requires the equipment to have minimal unwanted electromagnetic emissions and to also minimize its susceptibility to ambient electromagnetic energy, typically from nearby equipment or long-range radio transmitters.

EMI is the actual unwanted electromagnetic energy that designers need to suppress within their own designs, as well as protect their design from outside sources. These sources can be static electricity, other radios, sporadic emissions from motors or power supplies, mains hum, microwave ovens and the system's internal digital switching harmonics and sub-harmonics, and even audio signals. Their interference potential depends upon the operating frequency of the equipment under test (EUT) and they can manifest as continuous wave or pulsed EMI signals.

In EMC parlance, the system causing the interference is the source, and the system being affected is the victim. Between them are the four EMI coupling mechanisms: radiated, inductive, capacitive, and conductive, or any combination of the four, *Figure 3*. EMI can be viewed fractally in the sense that it applies between small or large systems that are near or far apart, as well as between subsystems, com-

ponents, traces, and antenna within a system. Not that antennas are particularly interesting, as they not only transmit and receive intentional emissions, but also serve as perfect couplers of EMI into and out of a system.

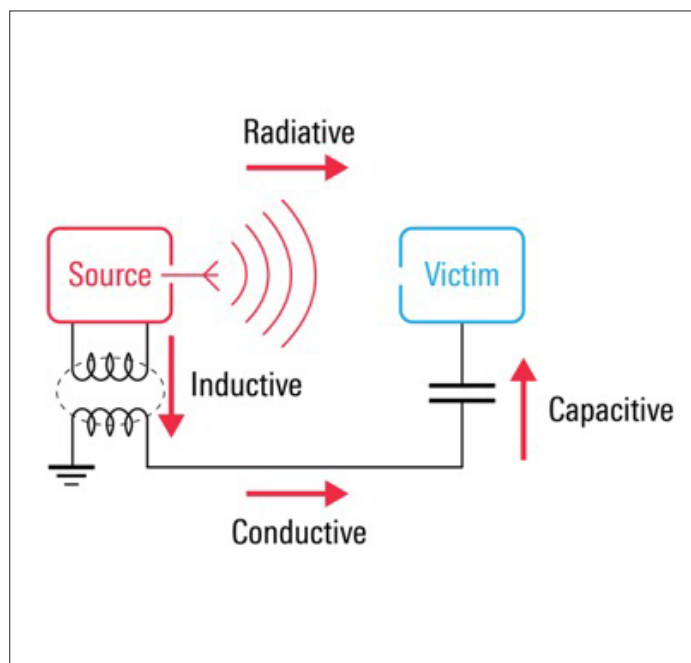

Figure 3: The four EMI coupling mechanisms are radiative, inductive, capacitive and conductive. (Image Source: ipfs.io)

The EMI and EMC principles are similar for nearby and within systems. For the sake of simplicity, this article will focus on a single system and how to design for EMC, perform pre-compliance testing, and debug using an off-the-shelf, mid-range oscilloscope.

DESIGNING FOR EMC

Let's consider the following basic principles to demonstrate that EMC hasn't changed since EE 101:

- Be careful on trace routing
- Be aware that higher speeds mean more EMI issues
- PCB stacking makes EMI worse
- Avoid sharp corners in traces (reasonable design tools can match the maximum trace angle to the operating frequency)
- Have larger ground planes
- Use shielded cables and housings
- Avoid discontinuities and resonances in the transmission path

Unfortunately, EMI cannot be eliminated entirely. Thus the designer's job is to manage and mitigate it, applying fundamental principles in combination with experiential know-how.

PRE-COMPLIANCE TEST AND DEBUG

Once the design is in the prototype stage and pre-compliance checkpoints have been established, the next task is to either isolate the EUT completely from ambient EMI, or to characterize the environment and account for detected

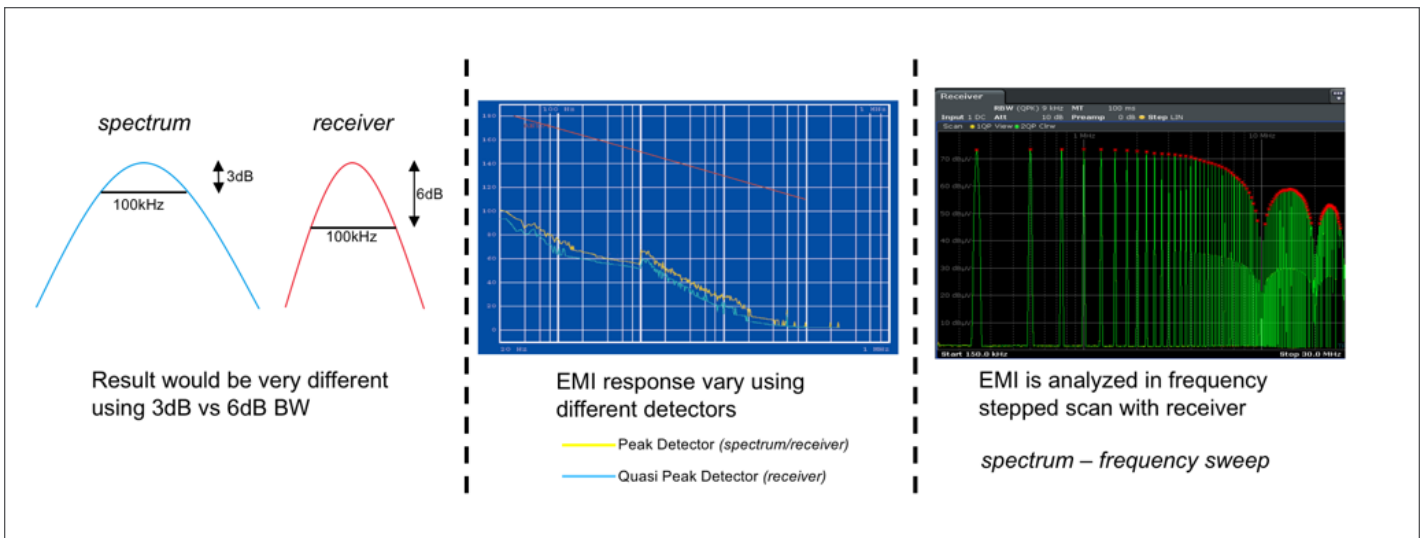

Figure 4: When in receive mode, spectrum analyzers can imitate higher cost EMI receivers, but make sure it has at least a quasi-peak (QP) detector with a directional antenna. (Image Source: Rohde & Schwarz)

interferers during the test cycle. Again, interferers also cannot be eliminated, but the probability of interference can be determined and mitigated.

To scan a wide range of frequencies for interferers, a full EMI receiver with an array of filters and wide dynamic range is a good option, but can be expensive. Alternatively, a spectrum analyzer can come close to an EMI receiver's capabilities without breaking the bank. Start by getting a baseline and account for any present signals. Spectrum analyzers, such as the R&S®FPC1500, have optional PC EMI software (Elektra) that can set the compliance limits, or the user can do it manually, *Figure 4*.

The spectrum analyzer itself will need at least a quasi-peak (QP) detector with a directional antenna as part of the minimum viable feature sets to approximate a full EMI-compliant receiver. Look for an analyzer with a frequency range from 5 kHz to 5 GHz to detect sub-GHz signals and 5-GHz Wi-Fi network interferers. Also, a built-in vector network analyzer (VNA) is useful as it can be used to match the antenna impedance to the RF module if there isn't an RF antenna built in.

Some spectrum analyzers also have an integrated signal generator that can be used to generate an additional signal in the presence of the intended transmitter signal. This "interferer" tests to make sure there is sufficient blocking at the receiver to allow the intended signal to get through.

To start pre-compliance testing, do a limit-line test, or max hold sweep, with a max hold detector, as that's a fast and easy test. Then, use the QP detector to do spot checks on any potential problem areas. Use electric field (E-field) and magnetic field (H-field) near-field probes, *Figure 5*. The magnetic field probe has a loop through which the magnetic field passes perpendicularly, inducing a detectable voltage

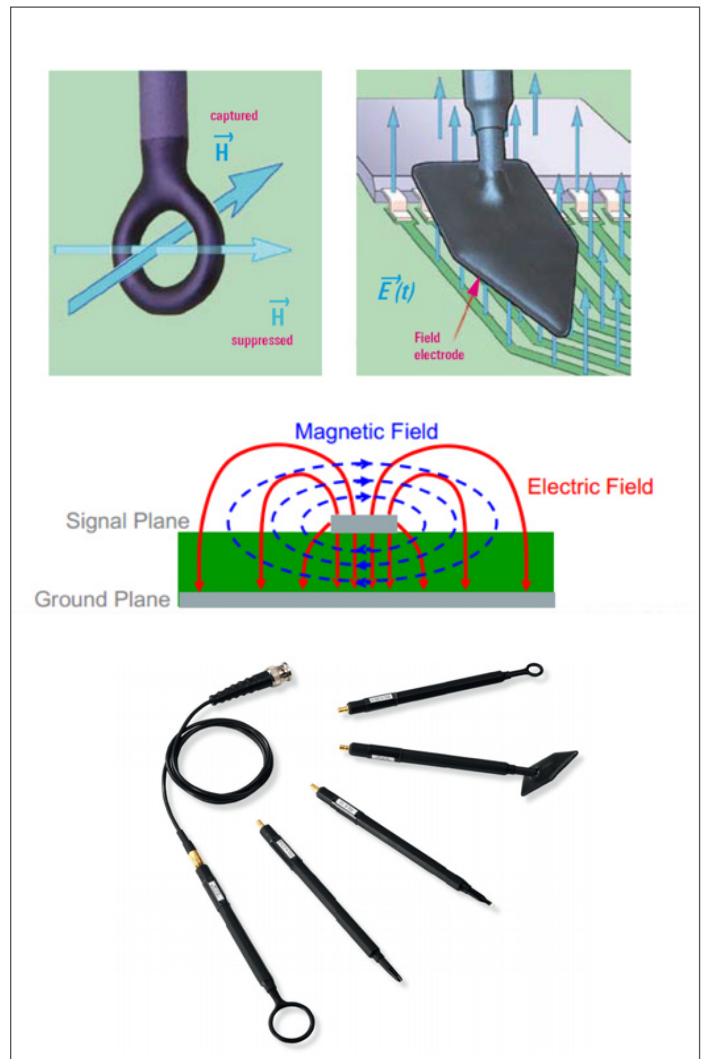

Figure 5: The larger the size of the E-field and H-field probes, the greater their sensitivity, at the cost of precision. It helps to zero in on the EMI source by reducing the size of the probe. (Image Source: Rohde & Schwarz)

When using the probes, it's important to keep in mind that the output of the probe very much depends upon the orientation of the probe relative to the emitters. Also, there is a trade-off to be made: the larger the probe, the greater the sensitivity, but the precision decreases. So, as the source of EMI gets more clearly defined, reduce the size of the probe to zero in on the source and verify that the readings are below the maximum power levels allowed.

This requires having a solid knowledge of the design to know where these might be. Many EMI sources can be anticipated by factoring in the clock frequencies, the power supply's switching frequency, and the expected harmonics.

Knowing the layout is critical, as it helps to know when a clock line might be too close to an RF module. This becomes something to watch for as it might be what's coupling in and causing another spur that's in a different part of the spectrum.

However, no matter how good a designer's knowledge of the physical layout and the circuit's design parameters, nothing beats running the system software and time-correlating the EMI to the running code.

TIME-CORRELATED TEST AND DEBUG WITH OSCILLOSCOPES

Given the budget and resource constraints of many IoT developers, a spectrum analyzer may be out of reach. However, every bench has an oscilloscope, and the right dig-

ital oscilloscope can also perform EMI test. This was not always the case, as the fast Fourier transform (FFT) processing capability wasn't available. That has changed, with some digital oscilloscopes now implementing FFT digital down-conversion and overlapping FFTs in hardware.

Look for a digital oscilloscope with these key characteristics: enough capture memory (can hold greater than 500 Ksamples), 50-Ω coupling impedance to ensure sufficient bandwidth and a sample rate >2x the maximum frequency, start with 2.5 Gsamples/s for 0 to 1 GHz. If testing systems with 2.45-GHz or 5-GHz radios, the sample rate will need to be upgraded accordingly. Also look for low noise and good vertical sensitivity capable of being set to 500 μV/div to 5 mV/div for high sensitivity over the full bandwidth.

As the probe will be moving around the board or system, it's important that the scope's response time be fast so there's no delay when trying to correlate EMI back to the time domain. Some scopes do include FFTs in software, so be careful to ensure the time and frequency domain are seen in real time. As the source of the EMI becomes clearer, the time-domain view should allow the EMI source to be correlated to changes such as bus level switching, *Figure 6*.

Other features to look for on a scope include a color table and screen persistence to easily detect and distinguish continuous wave signals, burst signals, and signal zoom: *Figure 7*.

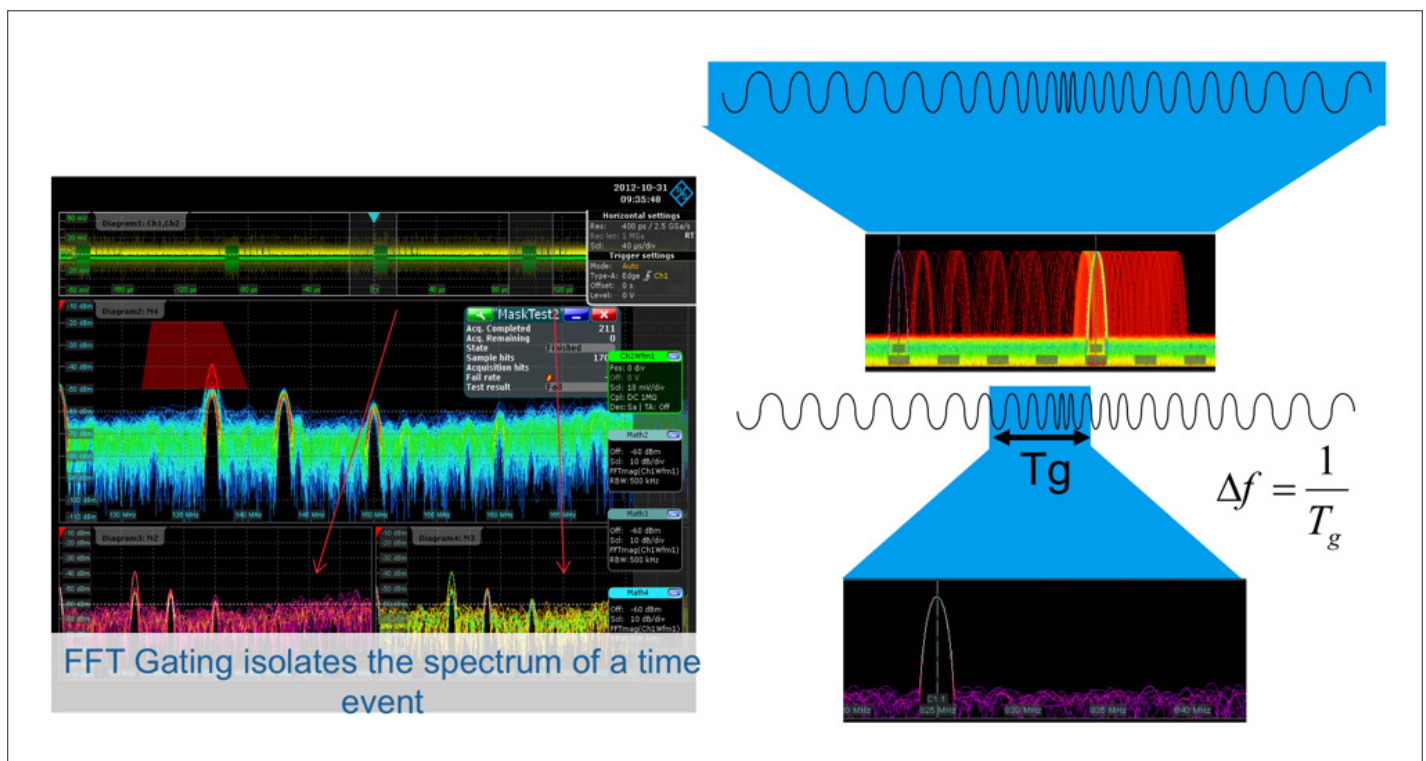

Figure 6: Multi-domain digital oscilloscopes with fast FFT capability and a gating feature help debug by allowing users to time-correlate EMI events and find their origin. (Image Source: Rohde & Schwarz)

CONCLUSION

In the age of IoT, with ubiquitous wireless connectivity, meeting EMC requirements for any standard is becoming more difficult and time consuming. The problem is exacerbated by the falling cost of IoT devices, which puts pressure on designers to get it right the first time to avoid extra cer-

tification costs and rework. That said, implementing a strict pre-compliance test regimen and checkpoints combined with typical benchtop equipment, such as digital oscilloscopes, can help limit formal and expensive EMC certification testing to one round.



Figure 7: The R&S®RTO2000's 10.1-inch capacitive touchscreen allows users to quickly navigate pop-up menus and adjust scaling by zooming in or moving a waveform. (Image Source: Rohde & Schwarz)



INTERFERENCE TECHNOLOGY AUTOMOTIVE



EMC EQUIPMENT MANUFACTURERS MATRIX

The following chart is a quick reference guide of test equipment and includes everything you'll need from the bare minimum required for key evaluation testing, probing, and troubleshooting, to setting up a full in-house precompliance or full compliance test lab. The list includes amplifiers, antennas, current probes, ESD simulators, LISNs, near field probes, RF signal generators, spectrum analyzers, EMI receivers, and TEM cells. Equipment rental companies are also listed. The products listed can help you evaluate radiated and conducted emissions, radiated and conducted immunity, and a host of other immunity tests, such as ESD and EFT.

EMC Equipment Manufacturers		Type of Product/Service													
Manufacturer	Contact Information - URL	Antennas	Amplifiers	Near Field Probes	Current Probes	Spectrum Analyzers/EMI Receivers	Software Simulation	ESD Simulators	LISNs	Radiated Immunity	Conducted Immunity	Pre-Compliance Test	TEM Cells	Rental Companies	RF Signal Generators
A.H. Systems	www.ahsystems.com	X	X		X							X			
Aaronia AG	www.aaronia.com	X	X			X						X			
Advanced Test Equipment Rentals	www.atecorp.com	X	X	X	X	X		X	X	X	X	X	X	X	X
Altair	www.altair.com						X								
AR RF/Microwave Instrumentation	www.arworld.us/	X	X			X	X		X	X	X	X			X
Anritsu	www.anritsu.com					X						X			X
Beehive Electronics	www.beehive-electronics.com			X								X			
Coilcraft	www.coilcraft.com	X	X												
CST Computer Simulation Technology	www.cst.com						X								
Electro Rent	www.electrorent.com		X			X		X	X	X	X	X		X	X
EM Test	www.emtest.com										X	X	X		
EMC Partner	www.emc-partner.com							X			X				
Empower RF Systems	www.empowerrf.com		X					X		X	X				
ETS-Lindgren	www.ets-lindgren.com	X	X	X	X			X	X	X	X	X	X		X
Fischer Custom Communications	www.fischercc.com			X	X			X				X			
Gauss Instruments	www.gauss-instruments.com					X									
Instrument Rental Labs	www.testequip.com		X			X		X	X	X	X	X		X	X

EMC Equipment Manufacturers		Type of Product/Service													
Manufacturer	Contact Information - URL	Antennas	Amplifiers	Near Field Probes	Current Probes	Spectrum Analyzers/EMI Receivers	Software Simulation	ESD Simulators	LISNs	Radiated Immunity	Conducted Immunity	Pre-Compliance Test	TEM Cells	Rental Companies	RF Signal Generators
Instruments For Industry (IFI)	www.ifi.com		X							X	X				
Keysight Technologies	www.keysight.com			X		X			X			X			X
Milmega	www.ametek-cts.com/about-us/brands/milmega		X							X	X				
MVG	www.mvg-world.com	X		X								X			
Narda/PMM	www.narda-sts.it	X	X			X			X	X	X	X			
Noiseken	www.noiseken.com							X			X	X			
Ophir RF	www.ophirrf.com		X								X				
Pearson Electronics	www.pearsonelectronics.com				X										
Rigol Technologies	www.rigolna.com		X	X	X	X	X					X			X
Rohde & Schwarz	www.rohde-schwarz.com	X	X	X	X	X	X		X	X	X	X			X
Siglent Technologies	www.siglent.com/			X		X	X					X			X
Signal Hound	www.signalhound.com			X		X	X					X			X
TekBox Technologies	www.tekbox.net		X	X			X		X			X	X		
Teseq	www.teseq.com		X		X			X		X	X	X	X		
Test Equity	www.testequity.com		X			X		X	X	X	X	X		X	X
Thermo Keytek	www.thermofisher.com							X			X				X
Thurlby Thandar (AIM-TTi)	www.aimtti.com					X						X			X
Toyotech (Toyo)	www.toyotechus.com/emc-electromagnetic-compatibility/	X	X			X			X	X		X			
TPI	www.rf-consultant.com											X			X
Transient Specialists	www.transientspecialists.com									X	X		X		
TRSRenTelCo	www.trsrentelco.com	X	X			X			X	X	X	X		X	X
Vectawave Technology	www.vectawave.com		X												
Windfreak Technologies	www.windfreaktech.com											X			X

REFERENCES

(TEST LABS, GROUPS, PUBLICATIONS, & LINKEDIN GROUPS)

AUTOMOTIVE EMC TEST LABS

Applus Laboratories (Australia)

<http://www.appluslaboratories.com/en/>

ARAI (India)

<https://www.araiindia.com/services/department-and-laboratories>

Cetecom

<http://www.cetecom.com/en/products-services/testing.html>

CKC Laboratories

<http://www.ckc.com/service/emc-testing/automotive-emc-testing/>

Dayton T. Brown

<http://www.dtbtest.com/EMI-Testing-EMC-Testing.aspx>

DLS

<https://www.dlsemc.com/emc-testing/emc-intro.htm>

Element

<https://www.element.com/landing/us-emc-emi-testing>

Element Materials

<http://www.nwemc.com/emc-testing-capabilities/military-aerospace-and-automotive-emc-testing>

Elite Electronic Engineering

<http://www.elitetest.com/testing-services/emc-testing/automotive-truck-emc-testing>

EMC Technologies

<https://www.emctech.com.au/emc-testing/automotive-emc-testing/>

Eurofins (UK)

<https://etcal.co.uk/automotive-emc-testing/>

Horiba Mira

<https://www.horiba-mira.com/facilities/>

Intertek

<http://www.intertek.com/automotive/electrical/emc-testing/>

Keystone Compliance

<https://keystonecompliance.com>

Marvell

<https://www.marvell.com>

MET Laboratories

<http://www.metlabs.com/services/emcemi-testing/>

National Technical Systems (NTS)

<https://www.nts.com/services/>

Nemko

<https://www.nemko.com/product-testing/emc-testing/automotive>

Seibersdorf Laboratories (Germany)

<https://www.seibersdorf-laboratories.at/en/home>

TÜV SÜD America

<https://www.tuv-sud-america.com/us-en>

Underwriters labs

<https://www.ul.com/automotive-and-mobility>

Yazaki Testing laboratory

<http://www.yazakiemc.com/wp/>

If your test lab specializes in automotive EMC testing and is not listed, please contact: james@lectrixgroup.com and we'll include you in the next issue.

REFERENCES (CONTINUED)

(TEST LABS, GROUPS, PUBLICATIONS, & LINKEDIN GROUPS)

AUTOMOTIVE INDUSTRY GROUPS

Auto Alliance

<http://www.autoalliance.org>

Automotive Industry Action Group

<http://www.aiag.org>

European Automobile Manufacturers Association

<http://www.acea.be>

National Automobile Dealers Association

<https://www.nada.org>

Automotive Council UK

<http://www.automotivecouncil.co.uk>

Automotive Industries Association of Canada

<https://www.aiacanada.com>

Center for Automotive Research

<http://www.cargroup.org>

German Association of the Automotive Industry

<https://www.vda.de/en>

Motor Trades Association of Australia

<http://www.mtaa.com.au>

PUBLICATIONS

2020 Automotive EMC Guide

The guide is comprised of the latest trends in technology, EMC design, standards, and pre-compliance testing in the automotive space.

<https://learn.interferencetechnology.com/2020-automotive-emc-guide/>

Interference Technology Engineer's Master (ITEM 2020)

Interference Technology Engineer's Master (ITEM) is an exhaustive guide full of invaluable EMC directories, standards, formulas, calculators, lists, and "how-to" articles, compiled in easy-to-find formats.

<https://learn.interferencetechnology.com/item-2020/>

AUTOMOTIVE INDUSTRY LINKEDIN GROUPS

- Auto OEM Network - World's Largest Automotive Group
- Automotive Industry Professionals Worldwide
- Automotive Management Professionals
- Automotive Industry Professionals
- Automotive OEM Professionals
- Managers of Automotive
- Automotive careers
- Automotive Engineers
- Automotive Electronics and Embedded Software
- The Next Mobility: Automotive & Transportation Industry Innovation
- Automotive PRO Network
- Automotive Infotainment, Telematics & Connectivity
- Automotive Testing
- Automotive Innovation
- Automotive Industry Innovation Group
- ASQ Automotive Division
- Automotive Quality Professionals
- Automotive Systems Engineers
- Center for Automotive Research - CAR
- Automotive Electrical and Electronics Manufacturing
- Automotive Cyber Security
- Automotive active safety / passive safety
- Automotive Electronics Community
- Automotive Sensors and Electronics
- ISO 26262 in Automotive Functional Safety
- Automotive Infotainment Testing
- The Automotive Engineer

TOP THREE EMI AND POWER INTEGRITY PROBLEMS WITH ON-BOARD DC-DC CONVERTERS AND LDO REGULATORS

Kenneth Wyatt

Wyatt Technical Services LLC
ken@emc-seminars.com

Steve Sandler

Picotest Systems, Inc.
steve@picotest.com

Modern devices are continuing a long-term trend of squeezing more electronics into smaller packages, while also increasing system performance, data rates and operating efficiency. Higher efficiencies are often achieved by implementing faster silicon MOSFETs or even faster eGaN FETs while size is reduced by increasing switching frequencies and replacing aluminum and tantalum capacitors with smaller ceramic devices. One result of this trend is that there is greater interaction between the disciplines of EMI, signal integrity (SI) and power integrity (PI).

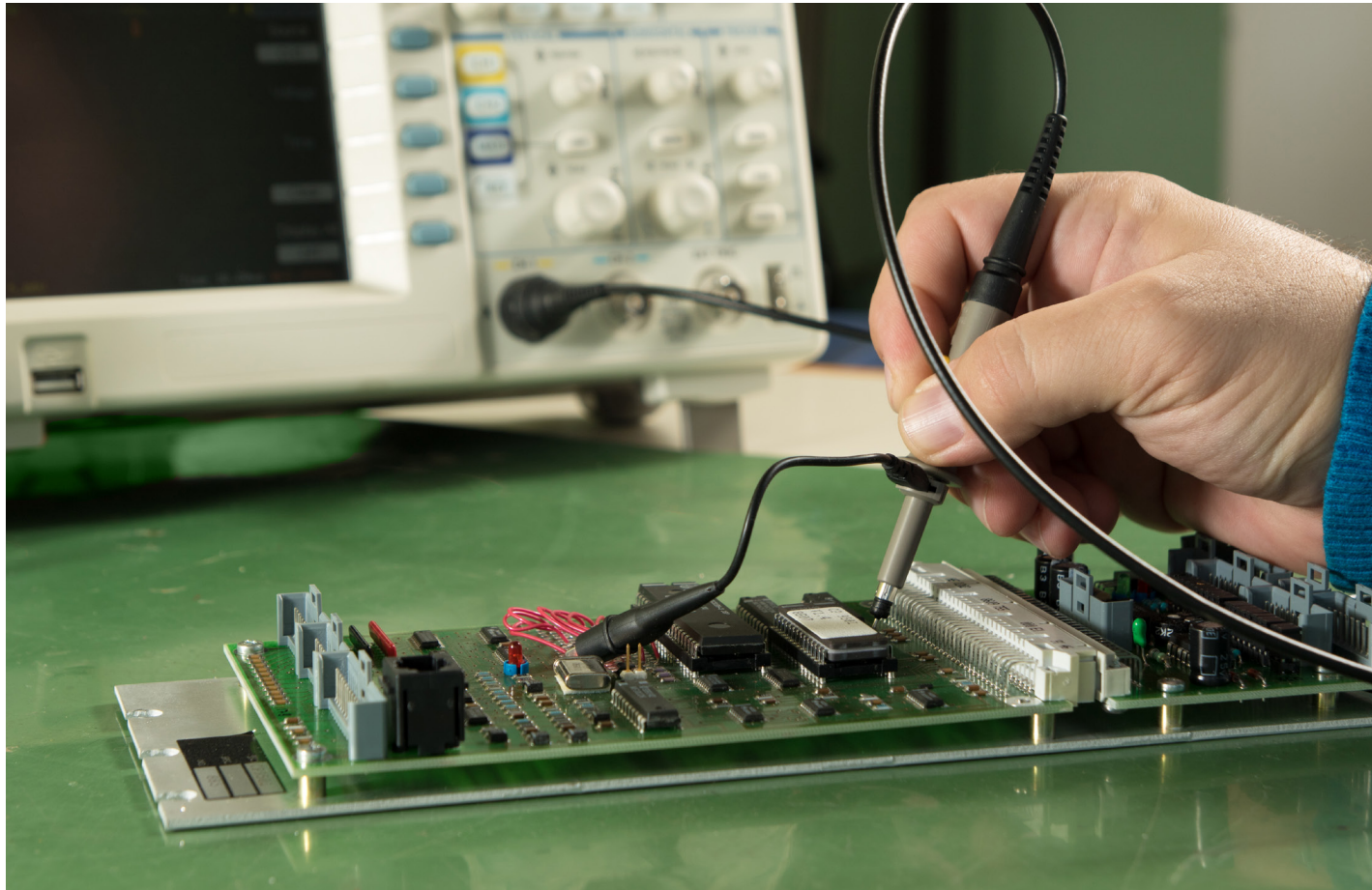

TOP THREE EMI AND POWER INTEGRITY PROBLEMS WITH ON-BOARD DC-DC CONVERTERS AND LDO REGULATORS

INTRODUCTION

EMI is a measure of the electromagnetic emissions produced by the high-speed current and voltage signals the system creates. Power integrity is a measure of the power quality at the device that being powered. This means that the power supply voltages must be maintained within the allowable operating voltage range of high-speed devices.

Devices, such as modems, reference clocks and low noise amplifiers (LNAs) are all sensitive to noise on the power rails, which results in timing jitter, spurious responses reduced data channel eye openings, and degraded signal-to-noise ratio (SNR). This too, is a measure of power integrity.

The power supply itself is a noise source and the noise sources generated by the power supply must be kept from propagating through the system.

This article discusses the three most common causes of EMI and power integrity issues while providing tips for how to avoid or minimizes them in your design,

1. **Ringing** on switched waveforms causes broad resonant peaks in the emission spectrum.
2. **DC-DC converters generate noise** at the switching frequency, and because of high speed switching devices, can generate broadband switching harmonics well into the GHz.
3. **Power plane resonance** in DC-DC converter or LDO regulators due to high-Q capacitors resonating with power planes.

RINGING AND RADIATED EMISSIONS

Any ringing on the switched waveform (fairly common) can lead to broadband resonances in the resulting RF spectrum. Resonant frequencies resulting from DC-DC converters or low dropout (LDO) linear regulators can be as low as a few kHz while resonance due to the PDN with switching devices, such as MOSFET's can be in hundreds of MHz or higher.

The harmonic energy resulting from this switching is "captured" by the PDN and device resonances, evident as ringing in the time domain. The current and voltage of this ringing produces EMI. The magnitudes of the ringing and EMI are related to the quality factor (Q) and characteristic impedance of the resonance and the harmonic energy produced by the switching.

As an example, the switching waveform on a DC-DC buck converter demo board was measured with a Rohde & Schwarz RTE 1104 oscilloscope and Rohde & Schwarz RT-ZS20 1.5 GHz active probe (Figure 1).

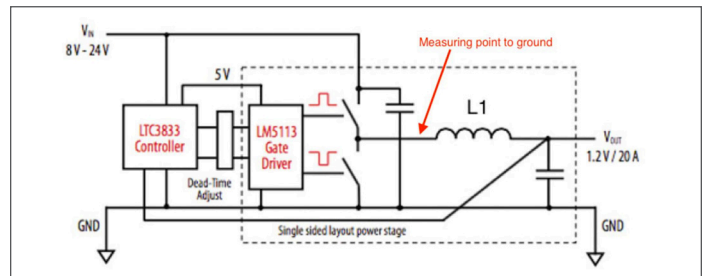

Figure 1. Diagram showing the measuring point at the switch device junction (on the left side of L1) to ground return.

There was a very large ringing superimposed on the switched waveform of 216 MHz. This can be seen clearly in Figure 2.

A Fischer Custom Communications F-33-1 current probe was used to measure both the input power cable common mode current (violet trace) and output load differential mode current (aqua trace). See Figure 3. Note the broad resonant peaks at 216 MHz (marker 1) and the second harmonic at 438 MHz (marker 2).

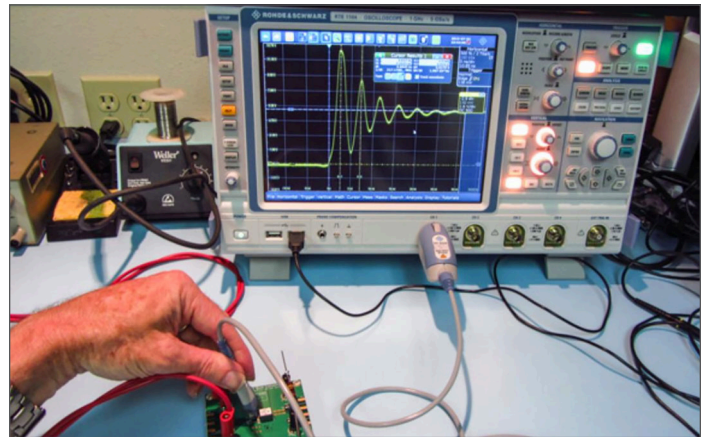

Figure 2. Measuring the rise time and ringing on a DC-DC converter. Notice to strong ringing at 216 MHz.

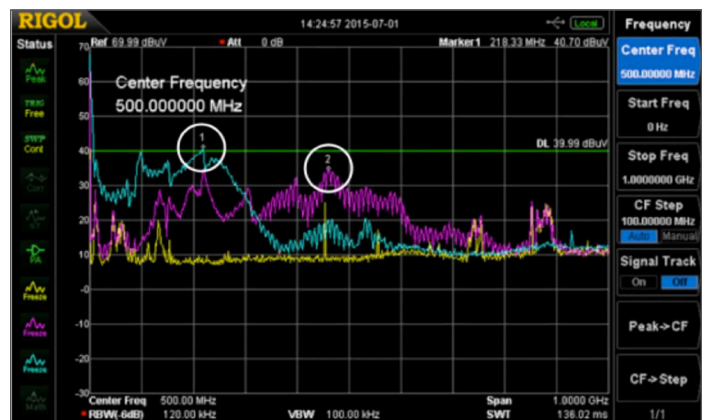

Figure 3. Resulting resonances from the 216 MHz ring frequency (marker 1) and second harmonic at 438 MHz (marker 2).

Remediation Tips - There are several ways to improve the design to minimize the resonances, ringing and therefore

EMI. Since the energy is related to the switching frequency, rise time of the switching, characteristic impedance, and Q of the resonances, these factors are also the paths to mitigation.

- Slower edges will degrade operating efficiency but reduce high frequency energy
- Careful PCB design and capacitor selection will minimize the characteristic impedance and Q
- Keep traces short and wide and dielectrics thin.
- Keep all the switching circuitry on one side of the board, preferably with a thin dielectric to the respective ground return plane.
- Use of a snubber circuit, damping of resonances using controlled ESR capacitors, or redesign of the inductor for lower leakage inductance.

For additional detail on measuring ringing refer to *Reference 1*.

FAST EDGES CREATE BROADBAND NOISE AT GHZ FREQUENCIES

Today's on-board DC-DC converters use switching frequencies as high as 3 MHz. This is an advantage because it allows for physically smaller inductor and filter components, as well as increased efficiency. However, the fast edge speeds create broadband harmonic energy. The bandwidth of this harmonic energy is related to the voltage and current rise time. A 1ns edge speed can produce harmonic energy up to 3 GHz, or more.

These broadband harmonics are the cause of radiated emissions failures and also can affect the receiver sensitivity of any on-board telephone modems or other wireless systems, such as GPS. *Figure 4* shows how a typical DC-DC converter circuit can be characterized using an H-field probe connected to a spectrum analyzer.

It's also possible to connect the probe to an oscilloscope and hold it near each DC-DC converter to get some idea of the ringing, if any, without disturbing the circuit.

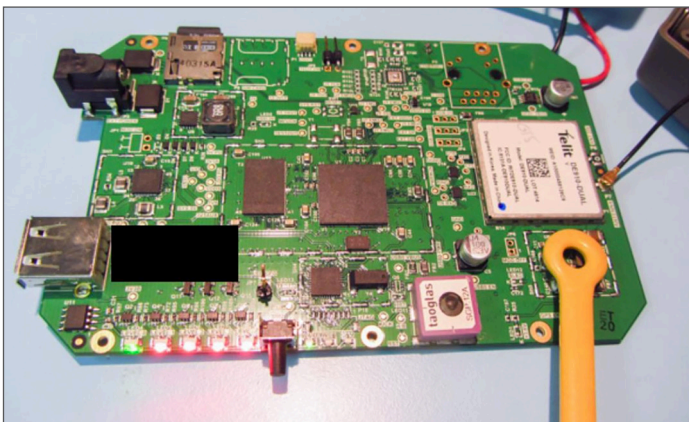

Figure 4. Probing DC-DC converter noise sources on a typical wireless device.

Figure 5 shows the resulting measurement of a couple DC-DC converters. The yellow trace is the ambient noise floor

of the measurement system and is always a good idea to record for reference. The aqua and violet traces are the two converter measurements. Note that both produce broadband noise currents out to 1 GHz, with the converter in violet out to beyond 1.5 GHz. Note the violet trace is 20 to 50 dB higher than the ambient noise floor.

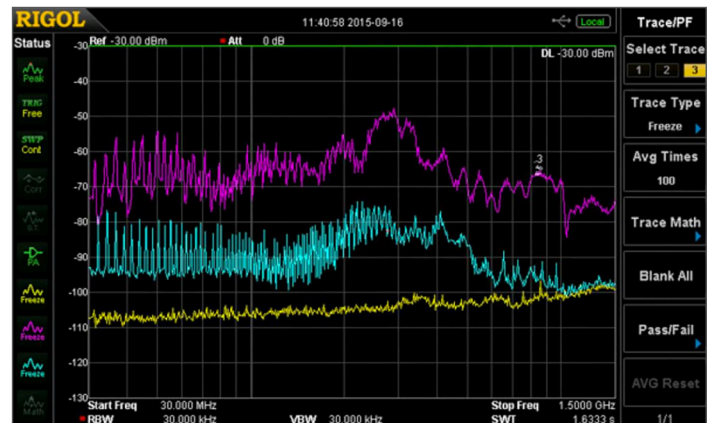

Figure 5 - In this example, we're looking from 30 MHz to 1.5 GHz to generally characterize the spectral emissions profile of a couple of on-board DC-DC converters. Both will potentially cause interference to mobile phone bands in the 700 to 950 MHz region. The one with the violet trace is over 30 dB above the ambient noise level in the mobile phone band.

Remediation Tips – To reduce the risk of self-interference to on-board mobile phone modems and wireless systems, the product design must start off with EMC in mind and with no corners cut.

This will consist of:

- A near perfect PC board layout
- Filtering of DC-DC converters
- Filtering of any high frequency device
- Filtering of the radio module
- Local shielding around high noise areas
- Possibly shielding the entire product
- Proper antenna placement

The PC board layout is critical and is where most of your effort should reside. An eight or ten layer stack-up will provide the most flexibility in segregating the power supply, analog, digital, and radio sections and provide multiple ground return planes, which may be stitched together around the board edge to form a Faraday cage. Care must be taken to avoid return current contamination between sections – especially in the ground return planes. For wireless products, the power plane for the radio modem section should be isolated (except via a narrow bridge) from the digital power plane. All traces to this isolated plane should pass over the bridge connecting the two. This can provide up to 40 dB of isolation between the digital circuitry and radio.

It is vital that the power and ground return planes be on adjacent layers and ideally 3-4 mils apart at the most. This will provide the best high frequency bypassing. All signal layers should be adjacent to at least one solid ground return plane.

Clock, or other high-speed traces, should avoid passing through vias and should not change reference planes. Power supply sections should be well isolated from sensitive analog or radio circuitry (including antennas). Be aware of primary and secondary current loops and their return currents. These return currents should not share the same return plane paths as digital, analog, or radio circuits. Remember that high frequency return currents want to return to the source directly under the source trace.

For more details on resolving DC-DC converter noise issues with wireless radio modems, refer to *Reference 2*.

PC BOARD PLANE RESONANCE AND THE EFFECT ON RADIATED EMISSIONS

Noise propagation in a simple system can be represented by three elements, the voltage regulator, the printed circuit board planes with decoupling capacitors (PDN) and the device being powered (load).

Each of these three elements is comprised of resistive, inductive and capacitive terms. Even “noise free” low drop-out (LDO) regulators can be highly inductive (*Reference 3*). The resistive, inductive and capacitive terms can resonate amplifying the noise signals created by the power supply and the load as they travel across the PDN creating EMI. The harmonics of the switching frequency and the switch ringing discussed earlier excite these PDN resonances (*Reference 4*). As stated previously this noise can degrade and interfere with on-board wireless modems, as well as resulting radiated and conducted emissions.

A short video helps explain the basic principles of PDN design (*Reference 5*). The radiated EMI of a LTC3880 DC-DC converter measured near the input plane using an H-field probe is seen in *Figure 6*.

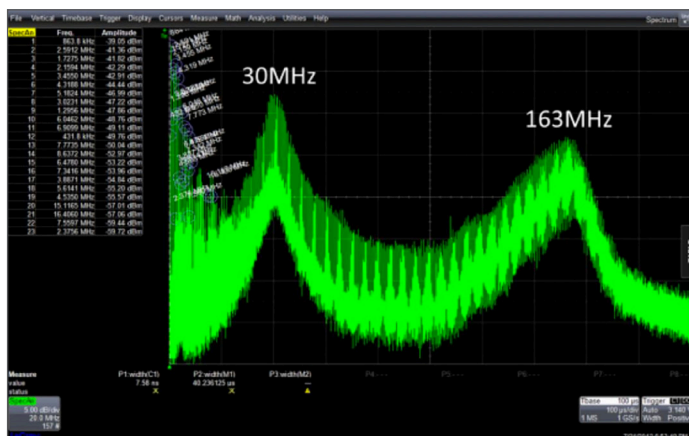

Figure 6. Spectrum analyzer display showing the 30 MHz and 160 MHz resonances detected near the input power connections of a DC-DC converter.

The 163 MHz is attributed to the ringing of the switches as seen in *Figure 7*. This ringing is caused by the inductance of the upper MOSFET bond wires, pins and circuit board planes, ringing with the lower MOSFET and PC board capacitance.

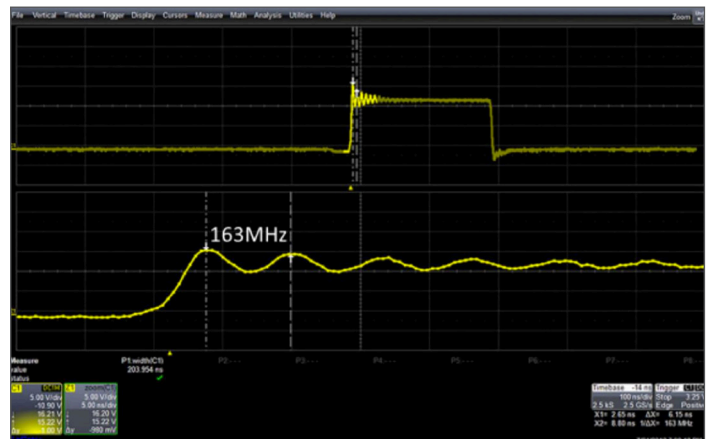

Figure 7. The 163 MHz EMI is easily explained by the ringing at the switch device, as discussed earlier.

The input ceramic decoupling capacitor resonates at approximately 30 MHz, as seen in *Figure 8* and results in the large 30 MHz EMI signature.

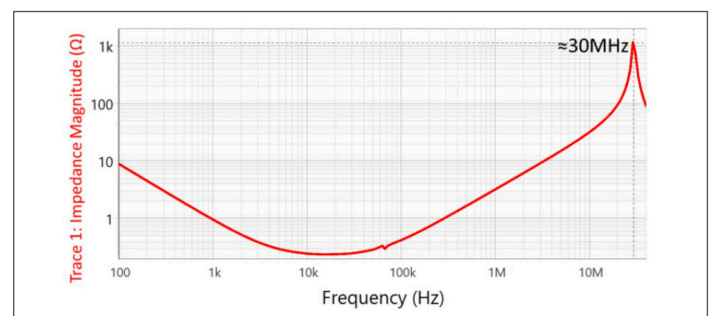

Figure 8. The larger 30 MHz emission is identified as a printed circuit board resonance using an H-field probe and confirmed by a 1-port reflection impedance measurement at the input capacitor.

The input power plane section of the DC-DC converter (measured in *Figure 6*) is shown in *Figure 9* with schematic representations of the component, PC board and external connections.

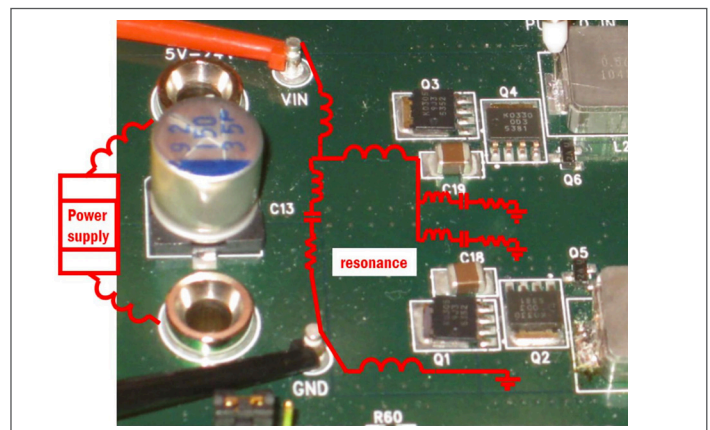

Figure 9. The power plane section of the DC-DC converter (measured in *Figure 6*) with schematic representations of the component, PC board and external connections.

A very simple simulation example can be used to illustrate these impedance resonance effects. Consider a simple

DC-DC converter as shown in *Figure 10*.

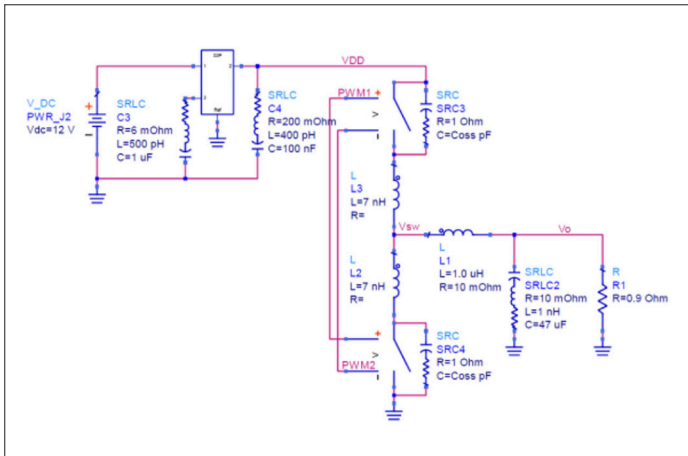

Figure 10. A simple DC-DC converter for illustration of plane resonance EMI. The “FET” switches include lead inductance and drain capacitance (Coss). A small PC board and two ceramic capacitors are included.

Designers frequently place the FET switches on one side of the board with power entry on the opposite side of the PC board. The small PC board plane used in this example has power entry through a pair of pins and no interconnect inductance is added to connect power to the PC board. A large 47 μF ceramic capacitor is placed on the top side of the PC board, while a smaller, 0.1 μF ceramic capacitor is placed very close to the FET switches on the bottom side of the PC board. Two parallel vias connect power and ground from the top side of the PC board to the bottom side as seen in *Figure 11*.

The simple model is used to simulate the harmonic current in the input connector, which is directly related to conducted and radiated emissions. Two simulations are performed; one with low ESR ceramic capacitors and the other with a lower Q controlled ESR ceramic replacing the 0.1 μF capacitor close to the FET switches. Both simulations are shown together in *Figure 12*.

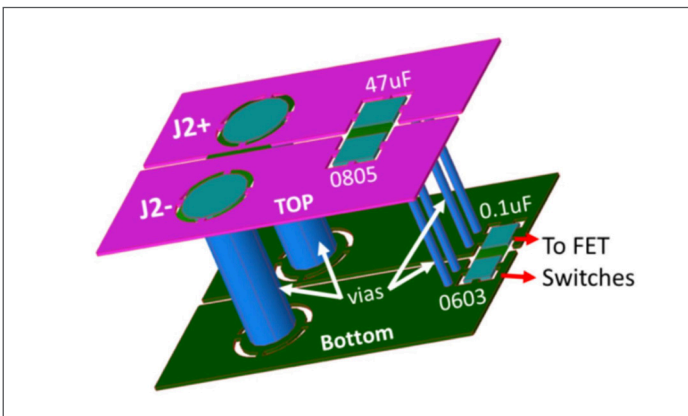

Figure 11. The large round pins on the left are the input power connector, J2. The larger capacitor on the top side is an 0805 sized 47 μF and the smaller capacitor on the bottom side is an 0603 sized 0.1 μF .

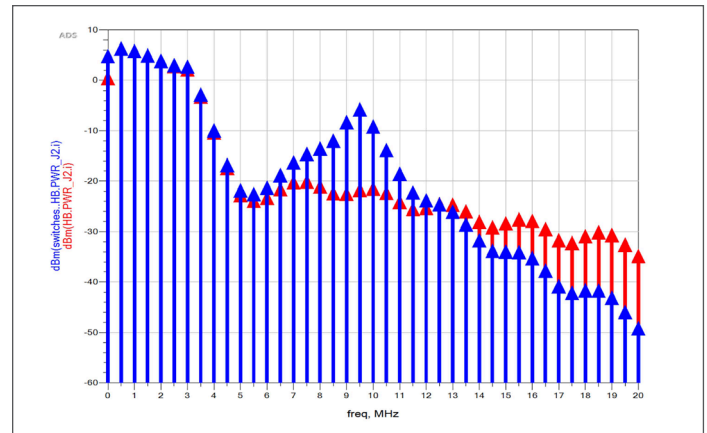

Figure 12. Spectral simulation of the input power lead shows the high Q ceramic (10 m Ω blue) has a clear peak near 10 MHz that is eliminated using a controlled ESR ceramic (200 m Ω red)

The simulated impedance, measured at the smaller capacitor in *Figure 13* shows the corresponding plane resonance with a clear 10 MHz peak using the high Q capacitor (blue) and the peak is eliminated using the controller ESR capacitor (red).

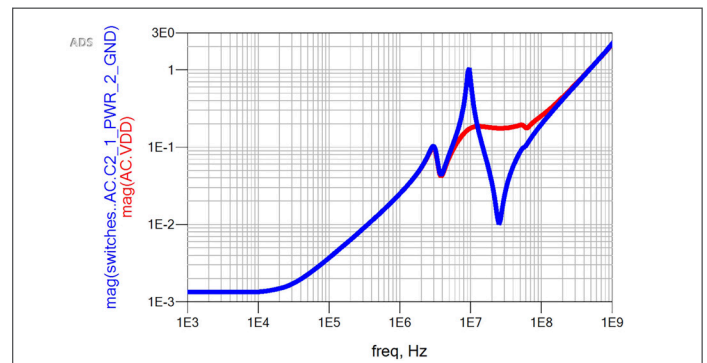

Figure 13. The simulated impedance at the 0.1 μF capacitor using high Q ceramic (10 m Ω blue) and a controlled ESR ceramic (200 m Ω red)

Remediation Tips – To minimize PDN resonances, the complete system of voltage regulator, PDN and the load need to be carefully balanced. Damping resistance must be included to eliminate or minimize the existence or Q of resonances. This will consist of:

- Short, wide power planes
- Keep the layout as small as possible to minimize inductance
- Thinner PC board dielectric layers, closer to the surface
- Incorporate EM simulation to identify and minimize PDN resonances
- Keep capacitors on one side of the PC board to the extent possible
- Low-Q or ESR controlled capacitors reduce Q
- Choose voltage regulators and output capacitors for good control loop stability
- Don't place cutouts or holes in ground plane layers below the power plane
- Ferrite beads are a very common cause of PDN reso-

nances

- Be aware of inductive interconnects bringing power to the system.

Printed circuit board design and decoupling is critical and “rules-of-thumb” generally don’t work well in high speed circuits. The design of the circuit board and capacitor decoupling always involves trade-offs, but the impacts on resonances need to be weighed carefully. A multi-frequency harmonic comb generator can be extremely helpful for quickly identifying PDN resonances (*Reference 3*).

SUMMARY

As you can see, designing DC-DC converters, LDOs, and PDNs with today’s high-speed technology nearly always requires careful circuit design, adequate filtering, simulation of the PDN, very careful circuit board layout, and use of controlled-ESR filter capacitors. Poor designs can result in:

- Ringing in power supply switches (or other fast-edged digital switching) resulting in associated radiated or conducted emissions resonant peaks at the ring frequency and harmonics.
- High frequency broadband noise well beyond 1 GHz, resulting in self-interference to radio modems.
- Poor stability and resonances in un-damped power distri-

bution networks, leading to instability, spectral resonances, and associated radiated and conducted emissions.

REFERENCES

1. Wyatt, GaN Technology and the Potential for EMI (EDN), <http://www.edn.com/electronics-blogs/the-emc-blog/4439839/GaN-technology-and-the-potential-for-EMI>
2. Wyatt, Platform Interference (EDN), <http://www.edn.com/electronics-blogs/the-emc-blog/4441086/Platform-interference>
3. Wyatt, Review: Picotest J2150A Harmonic Comb Generator <http://www.edn.com/electronics-blogs/the-emc-blog/4440532/Review--Picotest-J2150A-harmonic-comb-generator>
4. Sandler, The Inductive Nature of Voltage Control Loops, <http://www.edn.com/electronics-blogs/impedance-measurement-rescues/4438578/The-inductive-nature-of-voltage-control-loops>
5. Sandler, How to Design for Power Integrity: Finding Power Delivery Noise Problems (Video), https://www.youtube.com/watch?v=oL6qjhJH_m4&t=4s&list=PLtq84kH8xZ9HIYgBYDsP7TbqBpftid-zl8&index=4



1210CAN Series Common Mode Chokes

- Designed for common mode noise suppression on CAN or CAN FD in automotive or industrial automation applications
- 51 μH value meets IEC 6228-3 (CDV Annex D) requirements
- Filters a broad frequency range of common mode noise
- Can be used for FlexRay automotive bus system
- Low-profile 1210 footprint:
3.30 \times 2.67 \times 3.0 mm

Free Samples @ www.coilcraft.com

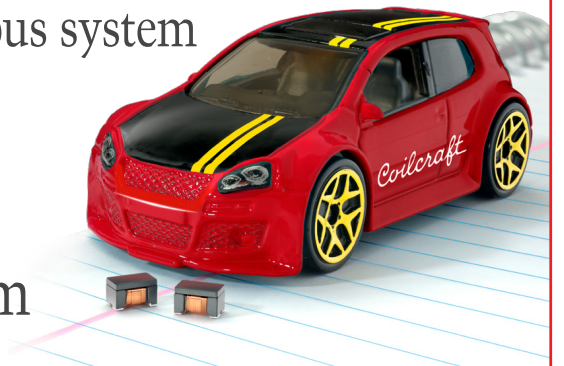

FIVE STEPS FOR SUCCESSFUL AUTOMOTIVE EMC DESIGN

By Sreevas P Vasudevan
Senior EMI/EMC Engineer

By Praveen S Mohan
Principal EMI EMC Engineer

EMI/EMC behavior of devices has become a major quality benchmark all over the world. The automotive industry follows several standards and stringent limits. Advancements in technology, customer requirements, along with harsher fuel emissions regulations, have resulted in the need to place more electrical and electronic systems into vehicles. In turn these resulted in the need of using electromagnetic compatible systems in the vehicle to avoid cross coupling between the systems and causing non-compliances or customer dissatisfaction.



FIVE STEPS FOR SUCCESSFUL AUTOMOTIVE EMC DESIGN

WHAT MAKES AUTOMOTIVE EMC SPECIAL?

Electronic systems in automotive involve in safety critical functions which include engine management, braking control, and airbag deployment, to name a few. Also, the automotive industry has seen a new generation of on board electronics for driver assistance devices and entertainment. Having the mobility of automobile, it can be exposed to different electromagnetic environments, from electromagnetically benign locations to electromagnetically harsh environments like airports with high radar fields.

Almost all automobiles today have sensitive AM/FM/DAB radio receivers (or perhaps even a land mobile VHF/UHF radio), so emissions from digital circuits are one of the biggest EMI problems facing today's designer of vehicular electronics. Most of the time the problem is annoying, but in the case of emergency vehicles (police, fire, ambulance), jamming a radio receiver could be life threatening. As a result, most vehicle manufacturers now require suppressing the offending emissions to extremely low levels.

In short, automotive emission requirements are aimed at protecting on board receivers (CISPR 25) and immunity requirements are very stringent to protect the safety critical on-board devices. Major Original Equipment Manufacturer (OEMs) had come up with their own standards which are more stringent than regulatory requirements. This make it essential for the suppliers to be fine tuning the EMC design best to suit the market.

EMC CONTROL - VEHICLE LEVEL OR ELECTRONIC SUB ASSEMBLY (ESA)

Understanding the fact that all major OEMs use electronics sub assemblies from more than one supplier for integrating in the vehicle, it is required by all major OEMs that the ESA fulfills the emission and immunity requirements. It can un-doubtedly say that making the ESA compliant to respective standards shall increase compliance possibility at the vehicle level testing, but, over the years it is proved that failure at vehicle levels are not completely avoided by making ESA compliant to EMC.

The article aims to provide a brief understanding for suppliers intended to produce products compliant and acceptable to Tier 1 OEMs.

I. UNDERSTAND THE REQUIREMENT

The automotive industry is a good example of responsible 'EMC regulation'. Country specific legal requirements are limited to generic clauses in the form of directives (for Europe) or FCC – Part 15 (United States). In addition to legal requirements, customer-based requirements are established by OEMs. Requirements of Tier 1 OEMs vary with each other in terms of standard followed, test limits and test type. A standardized test specification that cover major OEMs are far from reality even today [R1]. For radiated and conducted

emissions of ESA, OEMs use CISPR25 as guideline and for regulatory purpose at vehicle level emission results, CISPR12 is used. For immunity measurements the ISO 11452-series is referenced for ESA and ISO 11451 series is referenced at the vehicle level. These standards apply to vehicles powered by internal combustion engines, as well as hybrid and electric vehicles. Test distances and methods required to validate a product's performance are detailed in these standards. Some of the OEM specific standards, such as standards issued by General Motors, Ford and Fiat Chrysler requirements are available in the public domain. It is of utmost importance that product manufactures (of ESA) shall be aware of the OEMs they are targeting, and the respective levels of emission and immunity to be achieved.

Vehicle Level		Electronic Sub-Assembly	
Emission Standards	CISPR 12, EN 55012	Emission Standards	CISPR 25, EN 55025
Immunity Standards	ISO 11451-2 (Radiated Immunity)	Immunity Standards	ISO 11452-2 (Radiated Immunity)
	ISO 11451-3 (On Board Transmitter Immunity)		ISO 11452-3 (TEM Cell Method)
	ISO 11451-4 (BCI Method)		ISO 11452-4 (BCI Method)
	ISO 10605 (ESD)		ISO 11452-5 (Stripline)
			ISO 11452-7 (Direct RF Power Injection)
			ISO 11452-9 (Portable transmitter)
			ISO 10605 (ESD)

Table 1 - Automotive EMC Standards Overview

II. INCLUDE EMC IN DESIGN

It is often observed that EMC is taken into consideration at the final phase of the project, either after experiencing a compliance failure or at final sample stage. EMC design from the earliest stages of the project leads to easy implementation and cost-effective design approaches. When designing an electronic circuit, it is necessary to take several precautions to ensure that its EMC performance requirements can be achieved. Methods that can address EMC during the design are optimized as:

- Component selection and frequency selection
- PCB design for minimum radiation
- Cabing & Shielding

A. Component selection and frequency selection

For many automotive electronic systems, the embedded microcontroller is the only high-speed source of EMI on the board. If one can confine the selection of the component having lower emission profile and higher immunity performance, the EMC performance can be improved. Always ask for EMC compliance data for microcontrollers or passives used in the design. A detailed view EMC performance

graphs will help to identify the advantages and shortcomings of the components. Preparing a 'frequency table' (such as shown in *Table 2*) that list out the fundamental frequency and the dominant harmonics associated with each component would be a handy tool for better understanding of the circuit for design. Better design shall use frequencies that will not interfere constructively.

IC Reference	Radiated Emission Level	Radiated Immunity Level	Fundamental Frequency	Harmonic Frequency (1st, 3rd, 5th, 7th, 9th, 11th)	EMC Remarks

Table 2 - Component selection - Frequency check

B. PCB design for minimum radiation

Clocks & Harmonics: The primary sources of emissions from microcontroller based automotive systems are the clocks and other highly repetitive signals. A non-sinusoidal periodic waveform is composed of a fundamental frequency plus harmonic frequencies. The harmonics of these signals result in discrete narrowband signals that are typically within the VHF and UHF radio ranges. These harmonics are easily radiated by cables, wiring and printed circuit boards. The amplitude of square wave harmonics in digital systems decreases at the slowest rate (20 dB/decade) as frequency increases, and therefore are a rich source of high frequency harmonics. Any conductor will act as an efficient antenna when its physical dimensions exceed a (1/20) fraction of a wavelength. This shows that for a 300 MHz signal, a PCB trace of 5 cm can act as antenna. The design shall take care in avoiding PCB trace length comparable to the wavelength of the signal carried through it.

Spread Spectrum Clocking (SSC): Radiated emissions are typically confined in a narrow band centered around clock frequency harmonics. By uniformly distributing the radiation over a band of a few MHz, regulatory measurement levels (in a 120 kHz bandwidth at frequencies below 1 GHz and in a 1 MHz bandwidth at frequencies above 1 GHz) will be reduced up to 8 dB [R2].

Current Loop: Another key source of emissions is current flow. As processor speeds increase, the current requirement of the processor increases. Current flowing through a loop generates a magnetic field, which is proportional to the area of the loop. Loop area is defined as trace length times the distance to the ground plane. As signals change logic states, an electric field is generated from the voltage transition. Thus, radiation occurs because of this current loop and the voltage transition. The following *equation (1)* shows the relationship of current, its loop area, and the frequency to EMI (E-field): Since the distance to the ground plane is fixed due to board stack up requirements, minimizing trace length on the board layout is key to decreasing emissions.

$$\text{EMI (V/m)} = k \text{ I A f}^2 \quad (1)$$

Where:

k = constant of proportionality

I = current (A)

A = loop area (m²)

f = frequency (MHz)

Decouple Power Line: Whenever a digital circuit switches, it also consumes current at the switching rate. These pulses of power current will radiate as effectively as pulses of signal current. These switching peak currents cause more radiation since the power levels are usually much higher than those on an individual signal line. For devices with multiple power and ground pins, each pair of pins should be decoupled. High frequency capacitors in the 0.01–0.1 μf range should be installed as close as possible to the device V_{CC}. Also, high frequency capacitors (0.001 μf typical) shall be placed on the input and outputs of all on-board voltage regulators. This will protect these devices against high levels of RF energy and will also help suppress VHF parasitic oscillations from these devices. Keep the capacitors close to the devices, with very short leads.

C. Cabling & Shielding

Radio Frequency Immunity: The design method for better immunity to radio frequency is to avoid unwanted energy reaching vulnerable circuits. This requires high frequency filtering on cables (both power and I/O) which act as antennas and a careful circuit layout and circuit decoupling. To prevent coupling, noise carrying cables shall be placed away from chassis seams. Ferrite beads can be used to attenuate common mode noise on I/O cables. Provide adequate grounding for all cables. Both ends of cables shall be grounded to chassis ground.

The system case acts as shield and reduces EMI by containing EMI radiation. Effectiveness of the shield depends on the material used and the discontinuities in the case. Cable and module shielding are effective but are not popular in vehicular designs due to the costs.

III. REVIEW FOR EMC GUIDELINES

In the above section multiple EMC design methods are mentioned, it is important to suitably select the best possible methods based on the design considerations and cost impact. For better implementation, EMC design reviews shall be conducted at the sample stage. Introduction of front loading enables us to confirm the EMC design effect from the first prototype step and to reduce time for EMC improvement countermeasure at later stages. EMC review, hand in hand with design stage, helps to have a robust EMC design by ensuring major EMC checks are in place.

Structure of EMC design review- The EMC design review shall include the hardware circuit designer, PCB designer, mechanical designer, software designer and persons responsible for cable / interfaces. A detailed check for – Hardware selection, PCB guideline implementations, cable / interface connections must be performed at each review and

the potential EMC challenges shall be noted.

EMC design review can look for answers to important question like,

1. How severe are the EMC challenges for the circuit under design?
2. What should be the focus of the EMC design – PCB or at interface cables.
3. Is shielding of cables / critical circuits a possible solution?
4. Do we need an EMC simulation for a cost-effective implementation?
5. A facility for EMC pre-compliance is available or can be developed.

IV. PLAN FOR PRE-COMPLIANCE

Performing pre-compliance EMC testing avoids the risk of product failure and eliminates costly re-testing after design. EMC troubleshooting using near field probes for emission measurement are common nowadays, but for automotive device where the emission requirements are too stringent and immunity levels are too high, an exposure to actual test levels and setups is necessary to understand any pitfalls in design before final compliance testing. There are organizations having in-house equipment capable for automotive emission and immunity measurement, and these organization benefit from easy access and quick fix to EMC threats during design stage itself.

A. Common mode current measurement:

Measuring common-mode currents from cables can give an estimate of the radiated emission values, as radiated emission from cable is directly proportional to the common-mode current in that cable. We can use below equation to find out the amount of E-field emission.

$$E = \frac{12.6 \times 10^{-7} (f \times l \times I_{cm})}{r}$$

Where E is the e-field strength in uV/m, Icm is in micro amps, f is in MHz, r (distance from Antenna) & l (Length of the harness) are in meters. Common mode current can be measured with a high frequency clamp-on current probe and a spectrum analyzer / EMI Receiver.

A generic test setup for emission measurement for automotive devices using a LISN, current probe, and spectrum analyzer / EMI receiver is shown in figure 1.

B. 1m Radiated Emission test

Radiated emission testing can be performed as part of pre-compliance measurement with proper calibrated antennas if we can control or reduce the reflection of the emitted field. This can be achieved by keeping the DUT away from reflective surfaces. A lot of trial and error measurement may be required to build this setup in an internal lab. Small broadband antennas are the best choice for 1m EMC testing. A bi-conical antenna (30 – 200 MHz) and a

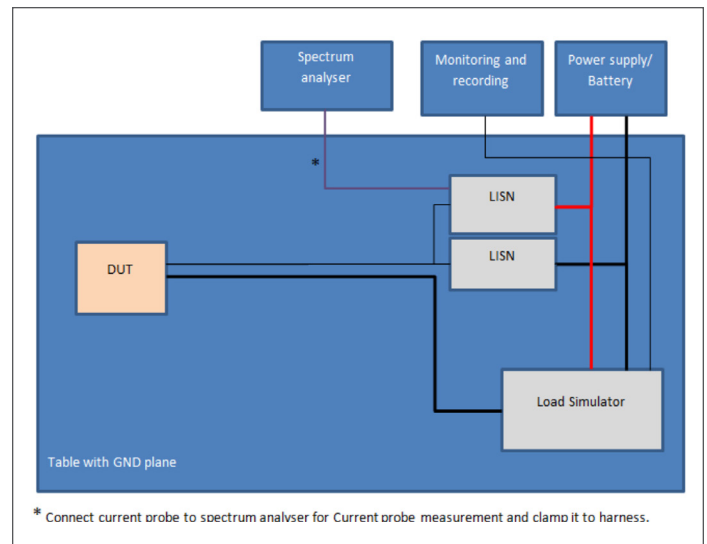

small log periodic antenna (200 – 1000 MHz) are suitable for this kind of measurement. Active antennas are the other option for this kind of test. The antenna needs to be placed 1m from the DUT. Connect the antenna to a spectrum analyzer and take measurements. A reference measurement with an approved lab can give a bench mark for the internal pre-compliance measurement. However at least a 6dB correction factor may be required with respect to an approved lab. Cost effective pre-compliance for radiated emissions can be made by the “Golden Product method” [R4] where the correction factors for the environment and equipment of pre-compliance measurement can be identified by comparing with a Golden sample whose radiated emissions behavior is already available from a test lab.

C. Pre-compliance Immunity testing

Measuring radiated immunity for automotive products without an anechoic chamber will be difficult to do as the fields are very high and it can interfere with the system around and with licensed radio services. Alternative ways to do this are to use hand held radio transmitters and place close to the device under test to check if these can cause any performance degradations. The BCI (ISO 11452-4) test in a small shielded room or shielded box can be used for understanding the immunity performance of the device up to 1 GHz [R3]. This is relatively less expensive than a fully installed antenna measurement.

With these methods, immunity performance of the product at different electromagnetic field levels can be observed and the product can be taken to an approved facility for further investigation and compliance testing.

D. ESD testing

ESD tests can be done in an internal lab with an ESD generator. Various models of ESD generators are available and these can be set up in an internal lab without much space and cost impact. Care should be taken to monitor the temperature and humidity of the area during the test time, as these environmental factors have impact on the static discharge.

V. SYSTEM INTEGRATION

Vehicle manufacturers are required to gain EMC approval for all vehicles. The electronic sub-assemblies, components and separate technical units are operated in full functionality for approval testing. Vehicles must not have electromagnetic emissions above the limits and must be immune to interference levels stated in the appropriate standards. Even though OEMs use sub-assemblies that have sufficient EMC robustness when tested individually, there exist a high chance that electromagnetic robustness for emission and immunity can be affected when different functional modules are integrated. These can be due to sharing of a common power supply or sharing a common communication network.

Inter-system radiated emissions and immunity of ESAs within the vehicle can be improved by proper positioning of the ESA in the vehicle. It is observed that for conventional automobiles with internal combustion engines, EMC sensitive equipment are positioned away from engine section where high power and high frequency switching noise are high. CAN, LIN and FlexRay are major communication networks. When devices are connected to a shared bus network, electromagnetic noise can be controlled by proper impedance matching design.

VI. CONCLUSION

Much advancement is happening in the automotive industry. As automotive systems are more and more occupied with electronic systems and subassemblies, EMI/EMC measurements became crucial for market certification and safety. It is required that automotive suppliers are positioned well in advance for EMC achievement. The above explained the key stages of a successful EMC achievement. Time for required for product development can be reduced if we only had a harmonized method of testing worldwide and with different OEMs. One day, methods and procedures might be unified for test execution that everyone can adopt. For now, by following a common EMC requirement and include EMC in the design strategy, a robust EMC design can more likely be achieved.

VII. REFERENCES

[R1] <http://web.archive.org/web/20120112140923/http://www.autoemc.net:80/Papers/Test/OHaraGenericEMC-Std.pdf>

[R2] Intel chip design for EMI - Application Note AP-589

[R3] <http://www.ieice.org/proceedings/EMC09/pdf/23R3-4.pdf>

[R4] EMC testing part 1- Radiated Emission- Cherry Clough Consultants 5 March 2007

[R5] CISPR 25 Vehicles, boats and internal combustion engines - Radio disturbance characteristics - Limits and methods of measurement for the protection of on-board receivers

[R6] CISPR 12 Vehicles, boats and internal combustion engines - Radio disturbance characteristics - Limits and methods of measurement for the protection of off-board receivers

AUTHOR BIOGRAPHY



Mr. Sreevas P Vasudevan is an innovative professional with eight years of functioning in the field of electromagnetic engineering. As a member of IET (MIET), he is an experienced electrical and electronics engineer with specialization in EMI/EMC design, analysis and system electromagnetic compatibility. He is independently involved in Automotive EMI EMC design & validation and acted as consultant for railway electromagnetic assurance for multiple metro projects in Auckland, Doha and London. Mr. Sreevas holds Patent in "ESD capacitor identification tool" registered at Indian patent office. He can be reached at sreevaspv@gmail.com



Mr. Praveen Mohandas is an EMC engineer with 13 years of experience in EMC design, development and validation. Praveen holds a bachelor's degree in Electronics and Communications and has hands-on experience in the field of EMC design, debugging and validations. He also has in-depth knowledge of EMC standards, legal requirements and various OEM requirements along with vehicle level EMC design reviews and validation process. Mr. Praveen is currently working in UK as a Principal Product Development Engineer in the field of EMC for Electric vehicle products. Praveen holds a patent, "ESD capacitor identification tool", registered under Indian Patent office. He can be reached at sm.praveen93@gmail.com

RESILIENCE IS KEY TO THE CONNECTED AND AUTONOMOUS REVOLUTION

Anthony Martin
EMC Chief Engineer, HORIBA MIRA

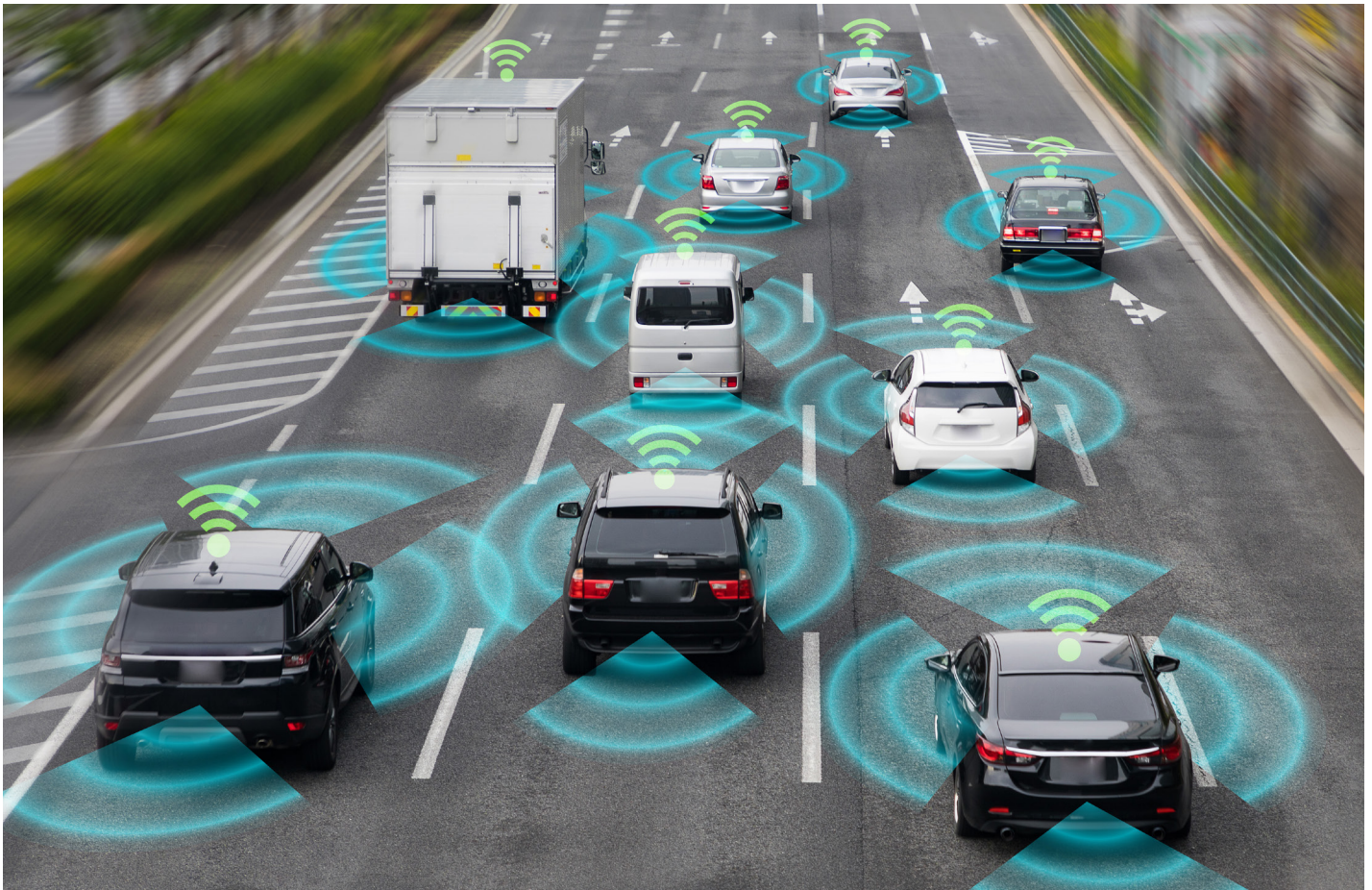

RESILIENCE IS KEY TO THE CONNECTED AND AUTONOMOUS REVOLUTION

INTRODUCTION

Connected and autonomous vehicles have long been hailed as the answer to safe transport. Around 1.25 million people die in road traffic accidents worldwide each year according to E&T—and driver error accounts for over 90% of those deaths¹. In theory, the removal of the driver as the lead decision maker for vehicle control should reduce this number, with the SMMT estimating that 2,500 lives will be saved between 2014 and 2032 through the introduction of autonomous vehicles. It is imperative however, that the industry ensures that the control technology underpinning the revolution remains safe, secure and functional as autonomous vehicle development progresses.

Artificial intelligence (AI) technologies, which utilize machine learning, are at the heart of vehicle automation. There have been significant strides in the development of the basic algorithms used in machine learning in addition to an increase in the amount of quality data available. Infrared sensors, light detection and ranging (LiDAR) systems, 360° vision systems, wireless connectivity and many more data sources all combine to provide machine learning algorithms with a wealth of rich information from which to learn, optimize and grow. It is now widely acknowledged that autonomous vehicles offer the application that AI has been waiting for, and that the introduction of autonomous vehicles will be sooner than we think.

Wireless technologies and the associated benefits that they bring are an ever-increasing and indispensable part of modern society. Services such as digital radio and TV (DAB and DVB-T), GSM, 3G, 4G, Wi-Fi, and Bluetooth are now commonplace in most executive and prestige vehicles. With demand increasing and implementation costs reducing, these technologies are becoming available across the majority of vehicles offered by manufacturers. For example, Bluetooth is common in all but the most basic entry level vehicles, and DAB and DVB-T are optional on most mid-range vehicles. Integrated GSM, 3G, 4G, 5G, and Wi-Fi technologies will be available in the next wave of models from the major high-end vehicle manufacturers, and along with intelligent transport systems (ITS), are set to deliver the much awaited 'connected car' and the connectivity backbone for autonomous vehicles.

For engineers though, who must look through the glossy benefits and get to the nuts and bolts of what is required to realize the change, a thorough understanding of the safety, security and functionality risks of each vehicle feature will be essential in ensuring that connected and autonomous technologies are resilient. These elements of the engineering process are inextricably linked, creating a web of intertwined and hidden risks. Security and safety systems must remain functional, whilst safety systems and functional systems must remain secure from cyber threats.

Standards form a key role in the engineering process, with ISO 26262 for functional safety and SAE J3061 for cyber security representing the state of the art for achieving high levels of system confidence. While changes are being implemented to tackle the issues surrounding connectivity and autonomy and significant work is undertaken to align the standards, even ISO 26262 Edition² scheduled for release in 2018 is unlikely to fully cover the requirements for autonomous vehicles. This is a reflection of the complexity of verifying the safe and secure operation of connected and autonomous vehicles rather than any inadequacy in the standards generation process.

It is the engineering processes within these standards, defining rigorous recommendations and regulations (throughout the product life-cycle from concept to decommissioning), that must be built upon to fully realize resilience for autonomous systems.

FUNCTIONAL PERFORMANCE

In order for connected and autonomous vehicles to function properly, we must ensure acceptable levels of performance for critical functions, such as braking, steering and acceleration. Key to this is the connected technology backbone; the broadcast systems and wireless links that enable connected vehicles to 'talk' to each other and to surrounding infrastructure. Data transmitted and received by vehicles will rise significantly, with vehicles using GSM, 3G, 4G, Wi-Fi, Bluetooth, vehicle-to-vehicle /infrastructure communication, and other data links and broadcast technologies.

Vehicle connectivity is improving, but not quickly enough for customers. According to J.D. Power's 2016 Vehicle Dependability Study, the number of problems with infotainment, navigation, and in-vehicle communication systems - collectively known as audio, communication, entertainment, and navigation or ACEN - has increased and now accounts for 20% of all customer-reported problems³.

For vehicle manufacturers, this poses a big issue as many customers will rate the quality of the entire electrical system in their vehicles based on the reception and connectivity experience that the vehicle delivers. Currently for mainstream vehicles, radio reception is the key tell-tale, but for high-end vehicles, this will extend to TV reception and interference. However, in the future customers will be armed with an increased number of diagnostic tools including data link corruption or dropouts, which will exhibit themselves as dropped phone calls, poor Wi-Fi reception or slow data rates. These will all form the tell-tale signs of electromagnetic interference issues or poor system/antenna performance. The irony is that the number of noise sources fitted to vehicles, and their proximity to sensitive antenna systems due to space constraints, are both causing an increased risk of electromagnetic issues and at the same time the means by which customers can perceive issues.

The risk of poor performance can lead to impact on the customer, such as the inability to make a phone call via the in-

tainment system, as well as warranty issues which lead to lengthy debates between customer, OEM and dealership. However issues will also reduce the effectiveness of vehicle features reliant on connectivity, some of which will be part of the vehicle control strategy. OEMs are acutely aware of these issues but are reliant on costly and time consuming subjective surveys to progress design development and gather data on connectivity performance issues meaning that signing off performance confidently is a challenge.

OEMs therefore require quantitative targets and meaningful performance measures for vehicle development. To meet these requirements for robust and accurate reception and connectivity assessment methods, a number of factors must be considered including; antenna performance, the level of wanted signal received by the vehicle when moving and the unwanted interference levels from the vehicle. All of these factors must be combined such that they reflect 'real-world performance', accurately simulating the vehicle occupant's experience to ensure that reception issues are identified and rated.

Connectivity is a key enabler in the future of mobility, and performance is crucial to feature functionality. Bottlenecks in connectivity must be avoided and data throughput must be maximized.

There are also many challenges ahead for electromagnetic testing of autonomous features, most of which surround the issue of system complexity. As functions are combined for co-pilot or auto-pilot features, system complexity grows rapidly. This in turn means that each system function is linked to multiple inputs from other vehicle systems. With this web of interconnectivity comes fragility, meaning fault modes are more likely. As such, test complexity increases due to the increase in stimuli for operational test modes. Efficient electromagnetic testing of autonomous features involves immersive situational testing, delivering services that use more diagnostic information, real-time vehicle data analysis, moving targets, and a number of other actuator and simulator systems.

SAFETY

Traditionally, safety has been considered to include active safety, such as anti-lock braking systems, blind spot information systems, and lane departure warning systems, as well as passive safety, including seat belts and airbags. However, with connectivity, electrification, and automation, safety has to be considered in a completely new light. First and foremost, new technologies mean engineers are having to get to grips with new systems and tools, which come with their own safety considerations. Secondly, new hazards are being created as a result of these new technologies. This includes exposure to electromagnetic energy and hazardous



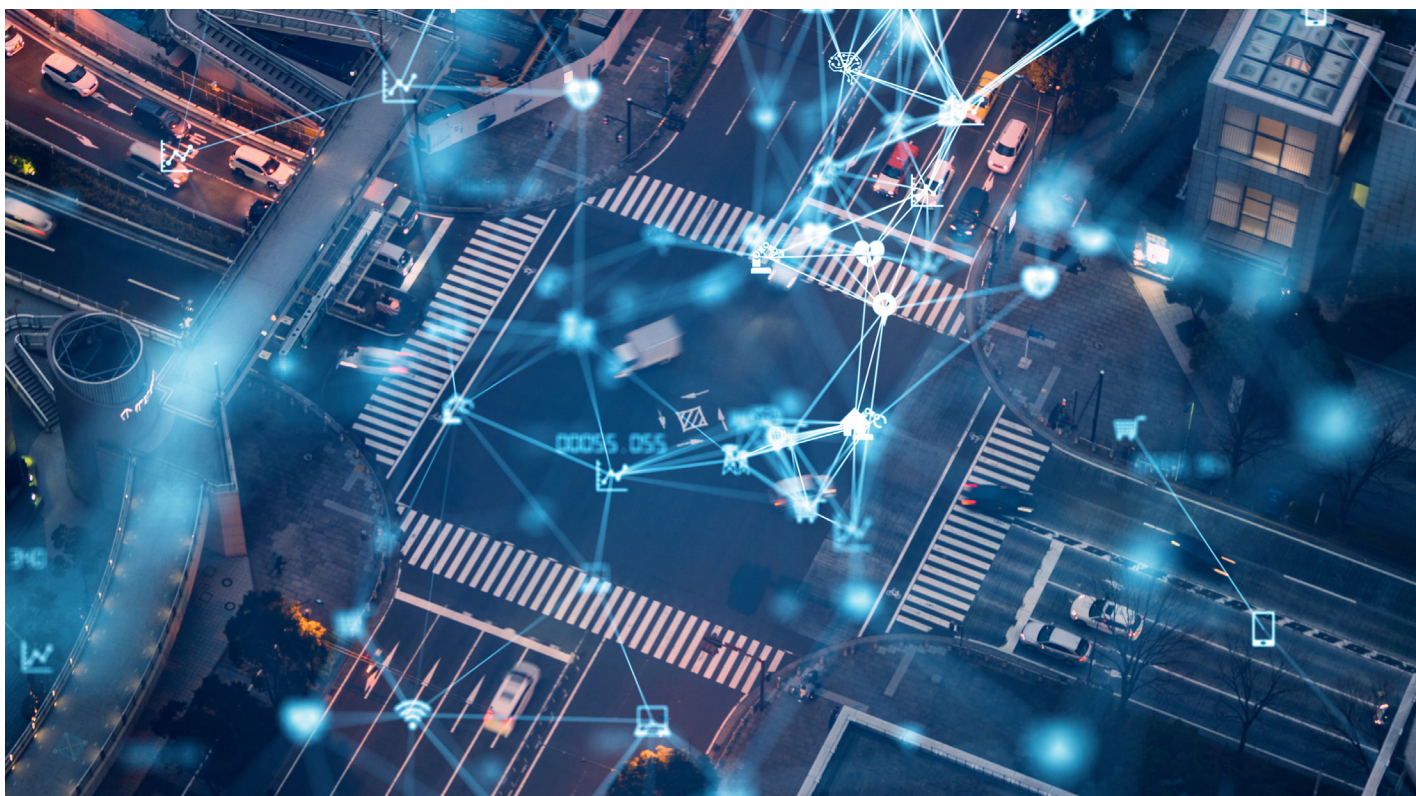

levels of electrical energy, potentially causing health-related issues, as well as thermal runaway, leading to thermal events, such as the release of chemicals.

System failures are another potential cause of hazards and can be caused by random hardware faults or systematic faults such as software defects. Widespread application of electronic systems in vehicles means it is especially important that safety risks are managed throughout product development. The ever increasing complexity of vehicle technology requires a coordinated approach to safety and functionality, and that the safety of security systems and the security of safety systems must be considered together. Only by undertaking coordinated, pragmatic and 'goal-based' programs can robust engineering solutions be delivered while avoiding unnecessary development rework, verification, and validation activities.

SECURITY

Increasing autonomy and connectivity has exposed us to the potential of greater levels of malicious activity in the form of cyberattacks. There are many potential threats that we face, including traditional vehicle theft, owners enhancing the performance of their own car, identity theft, or unauthorized remote access to vehicle functions. Each of these threats can have a variety of different consequences, including the financial, privacy, and operational impacts typically associated with the information security domain, as well as potential impacts upon safety and functionality.

In order to address these threats, we must use a risk-driven security engineering approach, through which appropriate security measures can be specified, designed, and

implemented. Effective verification and validation is required to evaluate whether the actual level of security is as designed, and whether it is effective at preventing the relevant attacks. This involves various review, analysis, and testing activities which take several forms, including verification of correct functional behavior, proper implementation of security mechanisms, vulnerability analysis, and penetration testing to confirm the effectiveness of those mechanisms.

Due to the diverse nature of the automotive supply chain, it is essential to perform this verification for individual hardware and software components, complete embedded systems and at vehicle level, to ensure that all elements are properly integrated.

It is clear that there are still challenges on the horizon yet to be fully addressed, but with a coordinated approach to safety, security, and functionality, we will be able to better map, manage, and mitigate the risks for connected and autonomous vehicles.

REFERENCES

1. https://www.gov.uk/government/uploads/system/uploads/attachment_data/file/401562/pathway-driverless-carssummary.pdf
2. <https://www.smmmt.co.uk/wp-content/uploads/sites/2/SMMTCAV-position-paper-final.pdf>
3. <http://www.jdpower.com/press-releases/2016-us-vehicledependability-study-vds>

EMCLIVE™

ANALYSIS
SENSOR

RF EMISSION

AUTONOMOUS

1G-2



EMC LIVE: AUTOMOTIVE

JUNE 8, 2021 | ONLINE

2021 EMC LIVE: Automotive brings experts in automotive EMC straight to your computer, speaking on topics like autonomous and electric vehicles, standards for automotive products, EMC theory and product design, and more.

All for **FREE**. Are you ready?

For More Information:
www.EMC.LIVE

PRESENTED BY INTERFERENCE TECHNOLOGY



INTERFERENCE TECHNOLOGY MILITARY & AEROSPACE



EMC EQUIPMENT MANUFACTURERS

Introduction

The following chart is a quick reference guide of test equipment and includes everything you'll need from the bare minimum required for key evaluation testing, probing, and troubleshooting, to setting up a full in-house precompliance or full compliance test lab for military and aerospace testing. The list includes amplifiers, antennas, current probes, ESD simulators, LISNs, near field probes, RF signal generators, spectrum analyzers, EMI receivers, and TEM cells. Equipment rental companies are also listed. The products listed can help you evaluate radiated and conducted emissions, radiated and conducted immunity and a host of other immunity tests, such as the new ESD test for MIL-STD-461G.

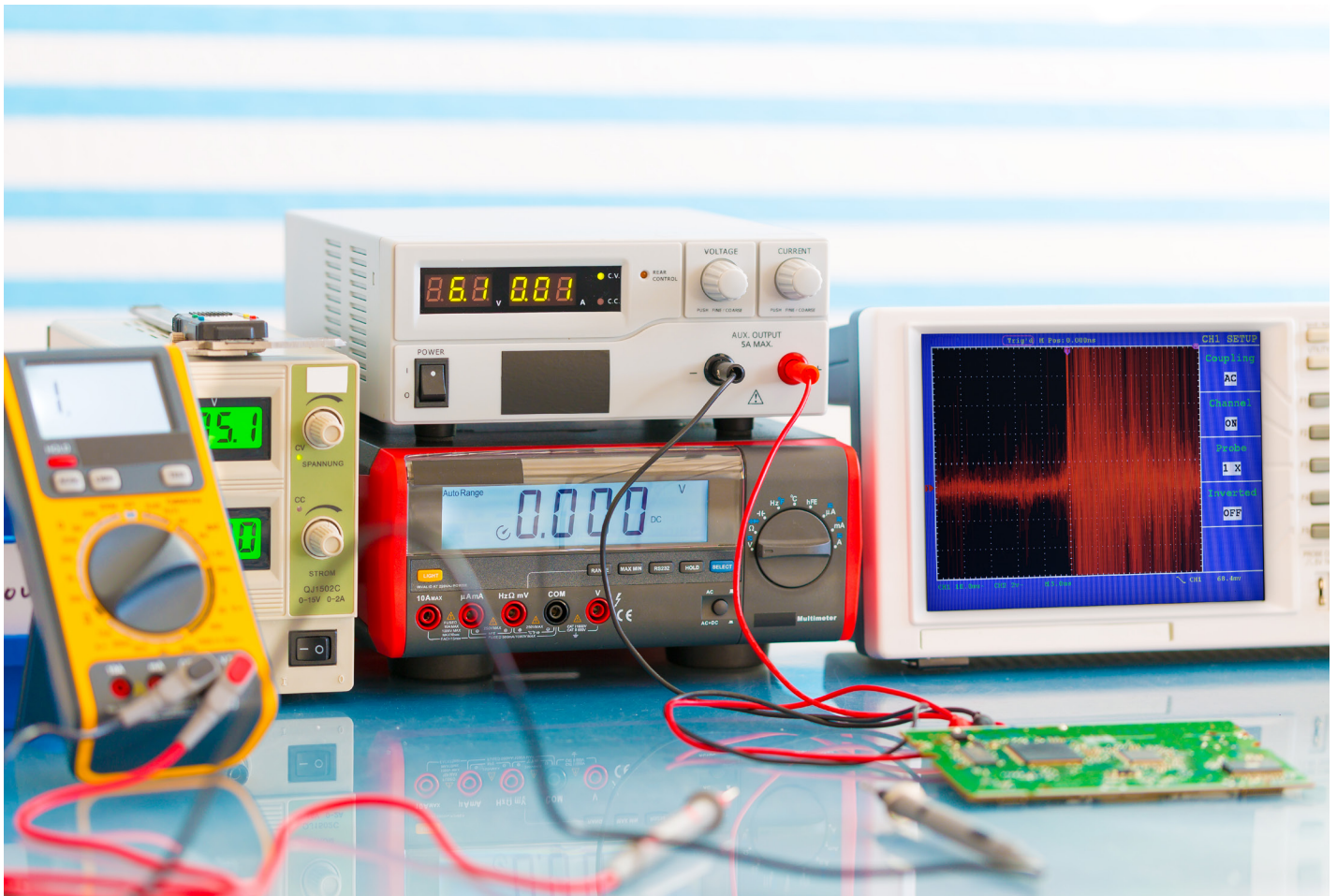

EMC Equipment Manufacturers		Type of Product/Service															
Manufacturer	Contact Information - URL	Amplifiers	Antennas	Conducted Immunity	Current Probes	EMC Filters	EMC Testing	ESD Simulators	LISNs	Near Field Probes	Pre-Compliance Test	Radiated Immunity	Rental Companies	RF Signal Generators	Software	Spectrum Analyzers/EMI Receivers	TEM Cells
A.H. Systems	www.ahsystems.com	X	X		X						X						
Aaronia AG	www.aaronia.com	X	X								X					X	
Advanced Test Equipment Rentals	www.atecorp.com	X	X	X	X			X	X	X	X	X	X	X		X	X
ALTAIR	www.altair.com														X		
Amplifier Research (AR)	www.amplifiers.com	X	X	X					X		X	X		X		X	
Anritsu	www.anritsu.com										X			X		X	
Electro Rent	www.electrorent.com	X		X				X	X		X	X	X	X		X	
EM Test	www.emtest.com/home.php			X							X						X
EMC Partner	www.emc-partner.com			X				X									
Empower RF Systems	www.empowerrf.com	X										X					
Fischer Custom Communications	www.fischercc.com				X				X	X	X						
Gauss Instruments	www.gauss-instruments.com/en/																X
Haefley-Hipotronics	www.haefley-hipotronics.com			X				X									
HV Technologies, Inc.	www.hvtechnologies.com	X		X								X		X		X	
Instrument Rental Labs	www.testequip.com	X		X				X	X		X	X	X	X		X	
Instruments For Industry (IFI)	www.ifi.com	X		X								X					
ITG Electronics	www.itg-electronics.com					X											
Keysight Technologies	https://www.keysight.com/us/en/home.html								X	X	X			X	X	X	
Microlease	www.microlease.com/us/home	X		X				X	X		X	X	X	X		X	
Milmega	www.milmega.co.uk	X		X								X					
Narda/PMM	www.narda-sts.it/narda/default_en.asp	X	X	X					X		X	X					X
Noiseken	www.noiseken.com			X				X			X						
Ophir RF	www.ophirrf.com	X		X													
Pearson Electronics	www.pearsonelectronics.com				X												
PPM Test	www.ppmtest.com		X								X	X			X	X	
R&B Laboratory	www.rblaboratory.com						X										
Rigol Technologies	www.rigolna.com				X					X	X			X	X	X	
Rohde & Schwarz	www.rohde-schwarz.com/us/home_48230.html	X	X	X	X			X	X	X	X	X		X	X	X	
Siglent Technologies	www.siglentamerica.com									X	X			X	X	X	
Signal Hound	www.signalhound.com									X	X			X	X	X	
Solar Electronics	www.solar-emc.com	X			X		X	X		X							
TekBox Technologies	www.tekbox.net	X							X	X	X				X		X
Tektronix	www.tek.com									X	X				X	X	
Teseq	www.teseq.com/en/index.php	X		X	X			X			X	X					X
Test Equity	www.testequity.com/leasing/	X		X				X	X		X	X	X	X		X	
Thermo Keytek	www.thermofisher.com/us/en/home.html			X				X									
Thurlby Thandar (AIM-TTi)	www.aimtti.us										X			X		X	
Toyotech (Toyo)	www.toyotechus.com/emc-electromagnetic-compatibility/	X	X						X		X	X				X	
TPI	www.rf-consultant.com										X			X			
Transient Specialists	www.transientspecialists.com			X								X					X
TRSRenTelCo	www.trsr-entelco.com/SubCategory/EMC_Test_Equipment.aspx	X	X	X					X		X	X	X	X		X	
Vectawave Technology	www.vectawave.com	X															
Windfreak Technologies	www.windfreaktech.com										X			X			

REFERENCES

(ARTICLE LINKS, DIRECTORIES, CONFERENCES, & LINKEDIN GROUPS)

LINKS TO LONGER ARTICLES

“MIL-STD-461G – The Compleat Review”

<https://interferencetechnology.com/mil-std-461g-compleat-review/>

“Selecting the Proper EMI Filter Circuit For Military and Defense Applications”

<https://interferencetechnology.com/selecting-proper-emi-filter-circuit-military-defense-applications/>

“Why is there AIR (In MIL-STD-461G)?”

<https://interferencetechnology.com/air-mil-std-461g/>

“Overview of the DO-160 standard”

<https://interferencetechnology.com/overview-of-the-do-160-standard/>

“Design for DO-160 pin injection for indirect lightning”

<https://interferencetechnology.com/design-for-do-160-pin-injection-for-indirect-lightning/>

“DO-160 cable bundle testing for indirect lightning”

<https://interferencetechnology.com/do-160-critical-sections-cable-bundle-for-indirect-lightning/>

CONFERENCE DIRECTORIES

AFCEA Events:

www.afcea.org/site/

ASCE Events:

www.asce.org/aerospace-engineering/aerospace-conferences-and-events/

ASD Events:

https://www.asdevents.com/shopcontent.asp?type=aerospace_defence

Aviation Week Event Calendar:

www.events.aviationweek.com/current/Public/Enter.aspx

Defense Conferences:

www.defenseconference.com/

Global Edge (MSU):

www.globaledge.msu.edu/industries/aerospace-and-defense/events/

IEEE AESS Events:

www.ieee-aess.org/conferences/home

Jane's Events:

www.janes.com/events

LINKEDIN GROUPS

- Aerospace and Defense Subcontractor and Suppliers
- Aerospace and Security and Defence Technology and Business (Defence spelled correctly)
- Defense and Aerospace
- EMP Defense Council
- High Intensity RF (HIRF) Professionals
- Radio, Microwave, Satellite, and Optical Communications
- RF/Microwave Aerospace and Defense Applications
- RF and Microwave Community

TABLE OF NEW EQUIPMENT ALLOWED/REQUIRED IN MIL-STD-461G

Tony Keys
EMC Analytical Services

Ken Javor
EMC Compliance

The following table was compiled by Ken Javor, of EMC Compliance. The updated changes to MIL-STD-461G require some new equipment. One of these changes allows the use of time domain EMI receivers, which will help speed up the testing, due to their fast FFT-based signal acquisition. Following is a list of some specific changes and equipment requirements:

CS101 (Conducted Susceptibility, Power Leads) - There is now a requirement to measure induced AC power line ripple. This requires a new "power ripple detector", which is a specially designed isolation transformer that matches the power line to 50 ohms.

CS114 (Conducted Susceptibility, Bulk Cable Injection) - This injection probe test now requires the use of a current probe calibration fixture to validate the test level during pre-calibration.

CS117 (Conducted Susceptibility, Lightning Induced Transients, Cables and Power Leads) - This is a new test added to MIL-STD-461G and requires a lightning transient simulator.

CS118 (Conducted Susceptibility, Personnel Borne Electrostatic Discharge) - This is a new test added to MIL-STD-461G and requires a standard electrostatic discharge simulator.

RS103 (Radiated Susceptibility, Electric Field) - This test requires an E-field antenna that can go down to 2 MHz.



Table of New Equipment Required for Latest Updates to MIL-STD-461 G			
Requirement	Equipment Type	Vendor(s)	Websites
General	Time Domain EMI receivers*	Amplifier Research	http://www.arworld.us/html/dsp-receiver-multiistar.asp
		Gauss Instruments	http://www.gauss-instruments.com/en/products/tdemi
		Keysight	http://www.keysight.com/en/pdx-x201870-pn-N9038A/mxe-emi-receiver-3-hz-to-44-ghz?cc=UG&lc=eng
		Rohde & Schwarz	https://www.rohde-schwarz.com/us/products/test-measurement/emc-field-strength-test-solutions/emc-field-strength-test-solutions_105344.html
CS101	Frequency domain ripple monitoring transducer* High-voltage differential probe, 100 MHz, 1k V(RMS) Digital Oscilloscopes (200 MHz - 4 GHz, 5/10 GSa/s)	Pearson Electronics	http://www.pearsonelectronics.com/news/179
		Rohde & Schwarz	https://www.rohde-schwarz.com/us/product/rtzd01-productstartpage_63493-34629.html
		Rohde & Schwarz	https://www.rohde-schwarz.com/us/product/rto-productstartpage_63493-10790.html or https://www.rohde-schwarz.com/vn/product/rte-productstartpage_63493-54848.html (with Option RTO-K17)
CS114	Current probe calibration fixture	ETS/Lindgren	http://www.ets-lindgren.com/EMC (fixture not listed on web site but should be part of current probe/injection clamp line-up)
		Fischer Custom Communications	http://www.fischercc.com/ViewProductGroup.aspx?productgroupid=141
		Pearson Electronics	http://www.pearsonelectronics.com/news/180 (fixture holds both injection clamp and current probe)
		Solar Electronics	http://www.solar-emc.com/RFI-EMI.html (scroll to bottom of page)
CS117	Indirect lightning test systems	HV Technologies	http://www.hvtechnologies.com/TestsTrack/Lightning/tabid/408/Default
		Thermo Scientific	http://www.thermoscientific.com/en/product/ecat-lightning-test-system-lts.html
		Solar Electronics	http://www.solar-emc.com/2654-2.html
CS118	ESD gun	EMC Partner	https://www.emc-partner.com/products/immunity/esd/esd-generator
		EM Test	http://www.emtest.com/products/productGroups/ESD_generators.php
		Haefely	http://www.haefely-hipotronics.com/product/product-category/electrostatic-discharge-test-systems-esd/
		Kikusui	http://www.kikusui.co.jp/en/product/detail.php?IdFamily=0020
		LISUN Group	http://www.lisungroup.com/product-id-318.html
		Noiseken	http://www.noiseken.com/modules/products/index.php?cat_id=1
		Thermo Scientific	http://www.thermoscientific.com/en/product/minizap-15-esd-simulator.html
TESEQ	http://www.teseq.com/product-categories/esd-simulators.php		
RS103	1 - 18 GHz electric field probe (most test facilities already have one)	Amplifier Research	http://www.arworld.us/html/field-analyzers-field-monitoring.asp
		ETS/Lindgren	http://www.ets-lindgren.com/EMCProbes
		NARDA	http://www.narda-sts.us/products_highfreq_bband.php

* Specified as acceptable for use, but not required.

MILITARY RELATED DOCUMENTS AND STANDARDS

The following references are not intended to be all inclusive, but rather a representation of available sources of additional information and point of contacts.

MIL-HDBK-235-1C Military Operational Electromagnetic Environment Profiles Part 1C General Guidance, 1 Oct 2010.

MIL-HDBK-237D Electromagnetic Environmental Effects and Spectrum Certification Guidance for the Acquisition Process, 20 May 2005.

MIL-HDBK-240A Hazards of Electromagnetic Radiation to Ordnance (HERO) Test Guide, 10 Mar 2011.

MIL-HDBK-263B Electrostatic Discharge Control Handbook for Protection of Electrical and Electronic Parts, Assemblies and Equipment (Excluding Electrically Initiated Explosive Devices), 31 Jul 1994.

MIL-HDBK-274A Electrical Grounding for Aircraft Safety, 14 Nov 2011.

MIL-HDBK-335 Management and Design Guidance Electromagnetic Radiation Hardness for Air Launched Ordnance Systems, Notice 4, 08 Jul 2008.

MIL-HDBK-419A Grounding, Bonding, and Shielding for Electronic Equipment and Facilities, 29 Dec 1987.

MIL-HDBK-454B General Guidelines for Electronic Equipment, 15 Apr 2007.

MIL-HDBK-1004-6 Lightning Protection, 30 May 1988.

MIL-HDBK-1195, Radio Frequency Shielded Enclosures, 30 Sep 1988.

MIL-HDBK-1512 Electroexplosive Subsystems, Electrically Initiated, Design Requirements and Test Methods, 30 Sep 1997.

MIL-HDBK-1857 Grounding, Bonding and Shielding Design Practices, 27 Mar 1998.

MIL-STD-188-124B Grounding, Bonding, and Shielding for Common Long Haul/Tactical Communications-Electronics Facilities and Equipment, 18 Dec 2000.

MIL-STD-188-125-1 High-Altitude Electromagnetic Pulse (HEMP) Protection for Ground-Based C41 Facilities Performing Critical, Time-Urgent Missions Part 1 Fixed Facilities, 17 Jul 1998.

MIL-STD-220C Test Method Standard Method of Insertion Loss Measurement, 14 May 2009.

MIL-STD-331C Fuze and Fuze Components, Environmental and Performance Tests for, 22 Jun 2009.

MIL-STD-449D Radio Frequency Spectrum Characteristics, Measurement of, 22 Feb 1973.

MIL-STD-461F Requirements for the Control of Electromagnetic Interference Characteristics of Subsystems and Equipment, 10 Dec 2007.

MIL-STD-461G Requirements for the Control of Electromagnetic Interference Characteristics of Subsystems and Equipment, 11 Dec 2015.

MIL-STD-464C Electromagnetic Environmental Effects Requirements for Systems, 01 Dec 2010.

MIL-STD-704F Aircraft Electric Power Characteristics, 12 Mar 2004.

MIL-STD-1275E Characteristics of 28 Volt DC Input Power to Utilization Equipment in Military Vehicles, 22 March 2013 (MIL-STD-1275F expected in 2021)
http://everyspec.com/MIL-STD/MIL-STD-1100-1299/MIL-STD-1275E_45886/

MIL-STD-1310H Standard Practice for Shipboard Bonding, Grounding, and Other Techniques for Electromagnetic Compatibility Electromagnetic Pulse (EMP) Mitigation and Safety, 17 Sep 2009.

MIL-STD-1377 Effectiveness of Cable, Connector, and Weapon Enclosure Shielding and Filters in Precluding Hazards of EM Radiation to Ordnance; Measurement of, 20 Aug 1971.

MILITARY RELATED DOCUMENTS AND STANDARDS

MIL-STD-1399 Section 300 Part 2 Medium Voltage Electric Power, Alternating Current 25 September 2018
<http://everyspec.com/MIL-STD/MIL-STD-1300-1399/>

MIL-STD-1542B Electromagnetic Compatibility and Grounding Requirements for Space System Facilities, 15 Nov 1991. MIL-STD-1605 Procedures for Conducting a Shipboard Electromagnetic Interference (EMI) Survey (Surface Ships), 08 Oct 2009.

MIL-STD-1686C Electrostatic Discharge Control Program for Protection of Electrical and Electronic Parts, Assemblies, and Equipment (Excluding Electrically Initiated Explosive Devices). 25 Oct 1995.

ADS-37A-PRF Electromagnetic Environmental Effects (E3) Performance and Verification Requirements, 28 May 1996.

DOD-STD-1399 Section 070 Part 1 D.C. Magnetic Field Environment, Notice 1, 30 Nov 1989.

DoDI 3222.03 DoD Electromagnetic Environmental Effects (E3) Program, 24 Aug 2014.

DoDD 4650.01 Policy and Procedures for Management and Use of the Electromagnetic Spectrum, 09 Jan 2009.

DoDI 6055.11 Protecting Personnel from Electromagnetic Fields, 19 Aug 2009.

AEROSPACE STANDARDS

AIAA Standards

<http://www.aiaa.org/default.aspx>

S-121-2009, Electromagnetic Compatibility Requirements for Space Equipment and Systems

RTCA Standards

<https://www.rtca.org/>

DO-160G, Environmental Conditions and Test Procedures for Airborne Equipment

DO-160G Change 1, Environmental Conditions and Test Procedures for Airborne Equipment

DO-233, Portable Electronic Devices Carried on Board Aircraft

DO-235B, Assessment of Radio Frequency Interference Relevant to the GNSS L1 Frequency Band

DO-292, Assessment of Radio Frequency Interference Relevant to the GNSS L5/E5A Frequency Band

DO-294C, Guidance on Allowing Transmitting Portable Electronic Devices (T-PEDs) on Aircraft

DO-307, Aircraft Design and Certification for Portable Electronic Device (PED) Tolerance

DO-307A, Aircraft Design and Certification for Portable Electronic Device (PED) Tolerance

DO-357, User Guide: Supplement to DO-160G

DO-363, Guidance for the Development of Portable Electronic Devices (PED) Tolerance for Civil Aircraft

DO-364, Minimum Aviation System Performance Standards (MASPS) for Aeronautical Information/Meteorological Data Link Services

DO-363, Guidance for the Development of Portable Electronic Devices (PED) Tolerance for Civil Aircraft

DO-307A, Aircraft Design and Certification for Portable Electronic Device (PED) Tolerance

SAE Standards

<http://www.sae.org/>

ARP 5583 – Guide to Certification of Aircraft in a High Intensity Radiation (HIRF) Environment <http://standards.sae.org/arp5583/>

SUMMARY OF MILITARY AND AEROSPACE EMC TESTS

Ghery Pettit

Pettit EMC Consulting

Ghery@PettitEMCConsulting.com

Introduction

Military and aerospace EMC tests cover a wide range of products. While the standards, including limits and test methods may differ, all EMC test standards have a few things in common. The most basic are the limits for emissions and the types and levels of susceptibility testing.

Emissions tests (and their associated limits) are put in place for military and aerospace equipment primarily to protect other systems from interference. These other systems may or may not include radio equipment. Examples abound showing the effect of inadequate EMC design.



SUMMARY OF MILITARY AND AEROSPACE EMC TESTS

While many military and aerospace EMC issues may be addressed by operational changes, testing is still required to find weaknesses.

Military and aerospace EMC testing is performed at the system and subsystem levels. MIL-STD-464C provides requirements at the system or platform level. The latest version, MIL-STD-461G, provides requirements at the equipment or subsystem level. *Reference 1* provides details on both of the standards, but this article will highlight some key tests, particularly as they relate to MIL-STD-461G.

Ratio	Description
CE101	Conducted Emissions, Audio Frequency Currents, Power Leads
CE102	Conducted Emissions, Radio Frequency Potentials, Power Leads
CE106	Conducted Emissions, Antenna Port
CS101	Conducted Susceptibility, Power Leads
CS103	Conducted Susceptibility, Antenna Port, Intermodulation
CS104	Conducted Susceptibility, Antenna Port, Rejection of Undesired Signals
CS105	Conducted Susceptibility, Antenna Port, Cross-Modulation
CS109	Conducted Susceptibility, Structure Current
CS114	Conducted Susceptibility, Bulk Cable Injection
CS115	Conducted Susceptibility, Bulk Cable Injection, Impulse Excitation
CS116	Conducted Susceptibility, Damped Sinusoidal Transients, Cables and Power Leads
CS117	Conducted Susceptibility, Lightning Induced Transients, Cables and Power Leads
CS118	Conducted Susceptibility, Personnel Borne Electrostatic Discharge
RE101	Radiated Emissions, Magnetic Field
RE102	Radiated Emissions, Electric Field
RE103	Radiated Emissions, Antenna Spurious and Harmonic Outputs
RS101	Radiated Susceptibility, Magnetic Field
RS103	Radiated Susceptibility, Electric Field
RS105	Radiated Susceptibility, Transient Electromagnetic Field

Table 1: MIL-STD-461G Emission and susceptibility requirements

MIL-STD-461G divides test requirements into 4 basic types. Conducted Emissions (CE), Conducted Susceptibility (CS), Radiated Emissions (RE) and Radiated Susceptibility (RS). There are a number of tests in each category and the following table, taken from MIL-STD-461G Table IV, shows these test methods.

A brief description of each these tests will be provided below. These are summarized from a more detailed introduction to MIL-STD-461G, which is found in the *References 1, 2, and 3*. Keep in mind that a complete copy of MIL-STD-461G is 280 pages, so any information here is brief and the standard must be read and understood. A copy of MIL-STD-461G may be obtained free. See *Reference 4*.

CE101 Conducted Emissions, Audio Frequency Currents, Power Leads. CE101 is applicable from 30 Hz to 10 kHz for leads that obtain power from sources that are not part of the EUT. There is no requirement on output leads from power sources. Emission levels are determined by measuring the current present on each power lead. There is different intent behind this test based on the usage of equipment and the military service involved. The specific limits are based on application, input voltage, frequency, power and current.

CE102 Conducted Emissions, Radio Frequency Potentials, Power Leads. CE102 is applicable from 10 kHz to 10 MHz for leads that obtain power from sources that are not part of the EUT. There is no requirement on output leads from power sources. The lower frequency portion is to ensure EUT does not corrupt the power quality (allowable voltage distortion) on platform power buses. Voltage distortion is the basis for power quality so CE102 limit is in terms of voltage. The emission levels are determined by measuring voltage present at the output port of the LISN. Unlike CE101, CE102 limits are based on voltage. The basic limit is relaxed for increasing source voltages, but independent of current. Failure to meet the CE102 limits can often be traced to switching regulators and their harmonics.

CE106 Conducted Emissions, Antenna Port. CE106 is applicable from as low as 10 kHz to as high as 40 GHz (depending on the operating frequency) for antenna terminals of transmitters, receivers, and amplifiers and is designed to protect receivers on and off the platform from being degraded by antenna radiation from the EUT. CE106 is not applicable for permanently mounted antennas.

CS101 Conducted Susceptibility, Power Leads. CS101 is applicable from 30 Hz to 150 kHz for equipment and subsystem AC and DC power input leads. For DC powered equipment, CS101 is required over the entire 30 Hz to 150 kHz range. For AC powered equipment, CS101 is only required from the second harmonic of the equipment power frequency (120 Hz for 60 Hz equipment) to 150 kHz. In general, CS101 is not required for AC powered equipment when the current draw is greater than 30 amps per phase. The exception is when the equipment operates at 150 kHz or less and has an operating sensitivity of 1 μ V or better.

The intent is to ensure that performance is not degraded from ripple voltages on power source waveforms.

CS103, CS104 and CS105 Conducted Susceptibility, Antenna Port, Intermodulation, Rejection of Undesired Signals and Cross-Modulation. This series of receiver front-end tests include test methods for Intermodulation (CS103), Rejection of Undesired Signals (CS104) and Cross Modulation (CS105). They were designed for traditional tunable super-heterodyne type radio receivers. Due to the wide diversity of radio frequency subsystem designs being developed, the applicability of this type of requirement and appropriate limits need to be determined for each procurement. Also, requirements need to be specified that are consistent with the signal processing characteristics of the subsystem and the particular test procedures to be used to verify the requirement.

CS109 Conducted Susceptibility, Structure Current. CS109 is a highly specialized test applicable from 60 Hz to 100 kHz for very sensitive Navy shipboard equipment (1 μ V or better) such as tuned receivers operating over the frequency range of the test. Handheld equipment is exempt from CS109. The intent is to ensure that equipment does not respond to magnetic fields caused by currents flowing in platform structure. The limit is derived from operational problems due to current conducted on equipment cabinets and laboratory measurements of response characteristics of selected receivers.

CS114 Conducted Susceptibility, Bulk Cable Injection. CS114 is applicable from 10 kHz to 200 MHz for all electrical cables interfacing with the EUT enclosures.

CS115 Conducted Susceptibility, Bulk Cable Injection, Impulse Excitation. CS115 is applicable to all electrical cables interfacing with EUT enclosures. The primary concern is to protect equipment from fast rise and fall time transients that may be present due to platform switching operations and external transient environments such as lightning and electromagnetic pulse.

CS116 Conducted Susceptibility, Damped Sinusoidal Transients, Cables and Power Leads. CS116 is applicable to electrical cables interfacing with each EUT enclosure and also on each power lead. The concept is to simulate electrical current and voltage waveforms occurring in platforms from excitation of natural resonances with a control damped sine waveform.

CS117 Conducted Susceptibility, Lightning Induced Transients, Cables and Power Leads. CS117 is one of two new test methods added to MIL-STD-461G. CS117 is applicable to safety-critical equipment interfacing cables and also on each power lead. Applicability for surface ship equipment is limited to equipment located above deck or which includes interconnecting cables, which are routed above deck. The concept is to address the equipment-level indirect effects of lightning as outlined in MIL-STD-464 and it is not intended

to address direct effects or nearby lightning strikes.

CS118 Conducted Susceptibility, Personnel Borne Electrostatic Discharge. CS118 is applicable to electrical, electronic, and electromechanical subsystems and equipment that have a man-machine interface. It should be noted that CS118 is not applicable to ordnance items. The concept is to simulate ESD caused by human contact and test points are chosen based on most likely human contact locations. Multiple test locations are based on points and surfaces which are easily accessible to operators during normal operations. Typical test points would be keyboard areas, switches, knobs, indicators, and connector shells as well as on each surface of the EUT.

RE101 Radiated Emissions, Magnetic Field. RE101 is applicable from 30 Hz to 100 kHz and is used to identify radiated emissions from equipment and subsystem enclosures, including electrical cable interfaces. RE101 is a specialized requirement, intended to control magnetic fields for applications where equipment is present in the installation, which is potentially sensitive to magnetic induction at lower frequencies.

RE102 Radiated Emissions, Electric Field. RE102 is applicable from 10 kHz to 18 GHz and is used to identify radiated emissions from the EUT and associated cables. It is intended to protect sensitive receivers from interference coupled through the antennas associated with the receiver.

RE103 Radiated Emissions, Antenna Spurious and Harmonic Outputs. RE103 may be used as an alternative for CE106 when testing transmitters with their intended antennas. CE106 should be used whenever possible. However, for systems using active antenna or when the antenna is not removable or the transmit power is too high, RE103 should be invoked. RE103 is applicable and essentially identical to CE106 for transmitters in the transmit mode in terms of frequency ranges and amplitude limits. The frequency range of test is based on the EUT operating frequency.

RS101 Radiated Susceptibility, Magnetic Field RS101 is a specialized test applicable from 30 Hz to 100 kHz for Army and Navy ground equipment having a minesweeping or mine detection capability, for Navy ships and submarines, that have an operating frequency of 100 kHz or less and an operating sensitivity of 1 μ V or better (such as 0.5 μ V), for Navy aircraft equipment installed on ASW capable aircraft, and external equipment on aircraft that are capable of being launched by electromagnetic launch systems. The requirement is not applicable for electromagnetic coupling via antennas. RS101 is intended to ensure that performance of equipment susceptible to low frequency magnetic fields is not degraded.

RS103 Radiated Susceptibility, Electric Field. RS103 is applicable from 2 MHz to 18 GHz in general, but the upper frequency can be as high as 40 GHz if specified by the procuring agency. It is applicable to both the EUT enclosures

and EUT associated cabling. The primary concern is to ensure that equipment will operate without degradation in the presence of electromagnetic fields generated by antenna transmissions both onboard and external to the platform. The limits are platform dependent and are based on levels expected to be encountered during the service life of the equipment. It should be noted that RS103 may not necessarily be the worst case environment to which the equipment may be exposed.

RS105 Radiated Susceptibility, Transient Electromagnetic Field. RS105 is intended to demonstrate the ability of the EUT to withstand the fast rise time, free-field transient environment of EMP. RS105 applies for equipment enclosures which are directly exposed to the incident field outside of the platform structure or for equipment inside poorly shielded or unshielded platforms and the electrical interface cabling should be protected in shielded conduit.

Not all tests are required for each type of device or intended use environment. MIL-STD-461G provides a matrix in Table V showing how these tests are used based on the intended use of the device.

Equipment and Subsystems Installed In, On, or Launched From the Following Platforms or Installations	Type of Product/Service																		
	CE101	CE102	CE106	CS101	CS103	CS104	CS105	CS109	CS114	CS115	CS116	CS117	CS118	RE101	RE102	RE103	RS101	RS103	RS105
Surface Ships	A	A	L	A	S	L	S	L	A	S	A	L	S	A	A	L	L	A	L
Submarines	A	A	L	A	S	L	S	L	A	S	L	S	S	A	A	L	L	A	L
Aircraft, Army, Including Flight Line	A	A	L	A	S	S	S		A	A	A	L	A	A	A	L	A	A	L
Aircraft, Navy	L	A	L	A	S	S	S		A	A	A	L	A	L	A	L	L	A	L
Aircraft, Air Force		A	L	A	S	S	S		A	A	A	L	A		A	L		A	
Space Systems, Including Launch Vehicles		A	L	A	S	S	S		A	A	A	L	A		A	L		A	
Ground Army		A	L	A	S	S	S		A	A	A	S	A		A	L	L	A	
Ground Navy		A	L	A	S	S	S		A	A	A	S	A		A	L	L	A	L
Ground, Air Force		A	L	A	S	S	S		A	A	A		A		A	L		A	

Legend:
A: Applicable (in green)
L: Limited as specified in the individual sections of this standard. (in yellow)
S: Procuring activity must specify in procurement documentation. (in red)

Table 2: MIL-STD-461G Requirement matrix

Again, the reader is referred to *References 1* through *3* for more details, or to MIL-STD-461G for the details of the standard (*Reference 4*). This guide also provides a list of standards that apply to various military equipment.

A popular and common aerospace EMC requirement required by the FAA for commercial aircraft is RTCA/DO-160, Environmental Conditions and Test Procedures for Airborne Equipment. The latest version is RTCA/DO-160 G,

published on December 8, 2010, with Change 1 published on December 16, 2015. DO-160 covers far more than just EMC issues, but the EMC subjects covered include input power conducted emissions and susceptibility, transients, drop-outs and hold-up; voltage spikes to determine whether equipment can withstand the effects of voltage spikes arriving at the equipment on its power leads, either AC or DC; audio frequency conducted susceptibility to determine whether the equipment will accept frequency components of a magnitude normally expected when the equipment is installed in the A/C; induced signal susceptibility to determine whether the equipment interconnect circuit configuration will accept a level of induced voltages caused by the installation environment; RF emissions and susceptibility; lightning susceptibility; and electrostatic discharge susceptibility.

This document can be purchased from RTCA on their website (*Reference 5*). A manufacturer producing products subject to the requirements in RTCA/DO-160 should obtain a copy and ensure they have a complete understanding of the content of the document and that any laboratory testing to it is properly accredited.

Examples of differences in test equipment between commercial and military standards.

There are differences in test equipment used compared with commercial EMC tests. Some examples are provided below.

Where 50 µH LISNs are universally required for commercial EMC tests, there are specific cases for CE01 and CE02 tests where a 5 µH LISN is called out. Limits for CE101 tests are provided in dBµA. LISNs are only used for line impedance stabilization. The measurements are taken with current probes. Limits for CE102, on the other hand, are given in dBµV and measurements are taken in much the same way as for commercial standards with the receiver connected to the RF output port of one of the LISNs and the other RF output port(s) terminated in 50 Ohms. It should be noted that MIL-STD-461G calls out a 20 dB pad on the output of the LISN to protect the receiver from transients. This is not a requirement in the commercial standards, but is worth considering when setting up a laboratory for commercial testing, as well.

Military EMC standards, such as MIL-STD-461G will require the use of different antennas for radiated emissions testing. Commercial equipment standards, such as CISPR 32 and ANSI C63.4, require the use of linearly polarized antennas and do not contain requirements for magnetic field testing.

MIL-STD-461G, RE101, requires the use of a 13.3 cm loop sensor, not required in the commercial standards. A receiver capable of tuning from 30 Hz to 100 kHz is needed.

MIL-STD-461G, RE102, requires testing of radiated emissions to as low as 10 kHz. From 10 kHz to 30 MHz a 104

cm (41 inch) rod antenna is used. This frequency range is not covered in CISPR 32 or the FCC Rules for radiated emissions. Thus, the antenna and receiver requirements are different. From 30 MHz to 200 MHz a biconical antenna is used, also commonly used in commercial testing. From 200 MHz to 1 GHz a double ridge horn antenna is called out in 461G. This is different than the tuned dipole or log periodic dipole array antennas used for commercial testing.

The test procedures are also different for radiated emissions testing, requiring different laboratory set-ups and test facility types. No turntable is needed for MIL-STD-461G, nor is an antenna mast capable of moving the antenna over a range of heights.

MIL-STD-461G, RS103, can require significantly higher field intensities for radiated susceptibility testing. Where CISPR 35 requires 3 V/m from 80 MHz to 1 GHz and at a few discrete frequencies up to 5 GHz (with the option of testing a few discrete frequencies at up to 30 V/m), MIL-STD-461G requires testing from 20 V/m to as high as 200 V/m over the range of 2 MHz to 40 GHz for certain equip-

ment. Additional test equipment (signal generators, amplifiers, antennas, etc.) is required over that needed for commercial testing.

Each test in MIL-STD-461G requires its own unique test equipment. Some may be useable for commercial testing, others may not. If testing to MIL-STD-461G, ensure that the equipment is proper for the tests being performed. A detailed understanding of the requirements in MIL-STD-461G is required to ensure that the proper equipment is being used and the laboratory is following the appropriate processes.

REFERENCES

1. 2016 Military EMC Guide, *Interference Technology*
2. Ken Javor, MIL-STD-461G: The "Compleat" Review, *Interference Technology*, April 2016
3. Ken Javor, Why Is There AIR (in MIL-STD-461G)?, *Interference Technology*, April 2016
4. MIL-STD-461G, December 2015, Defense Acquisition System
5. RTCA/DO-160G, RTCA, December 2010.



CPxxxFRA Family

Common Mode Chokes for Critical Applications

- Eliminate virtually all common mode noise
- Designed for high-speed USB 3.0, HDMI, SATA, IEEE1394 and LVDS applications
- Most values provide >15 dB common mode attenuation and >100 ohms impedance
- Support data rates up to 4.8 Gbit/s
- Standard 0603 and 0805 footprints

Learn more @ coilcraft-cps.com

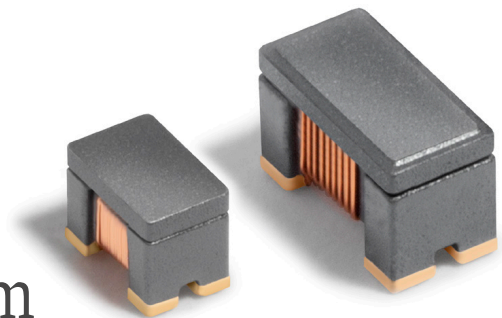

REVIEW OF MIL-STD-461 CS117 LIGHTNING INDUCED TRANSIENTS, CABLES AND POWER LEADS

Steve Ferguson

Compliance Direction LLC

stevef@compliancedirection.com



INTRODUCTION

Lightning may produce a spectacular display when viewed, but the associated electromagnetic effects (EME) has the potential (pun intended) to severely damage electrical and electronic circuits. MIL-STD-461G added a new test method to evaluate device tolerance for induced current on equipment cables or insulation breakdown from the effects of indirect lightning. Although new to MIL-STD-461, the induced lightning tests have a background in civil aviation with similar test methods documented in RTCA/DO-160.

Most equipment has been evaluated for effects from indirect lightning events using CS115 and CS116 test methods for several years and these test methods remain present in revision "G" for qualifying equipment. The CS117 test method addition primarily targets aircraft flight or safety critical equipment and some other critical applications calling for this evaluation.

Note that the CS117 test method does not provide test coverage for MIL-STD-464 lightning direct effects or nearby lightning requirements.

PLANNING FOR TEST

Is testing applicable to my device?

MIL-STD-461G, Table V lists CS117 as having Limited (L) applicability or Specified (S) in procurement contract documents. The Limited applicability defers to as specified in individual section of the standard. The individual section (5.15) lists applicability as safety-critical equipment and applies testing to the interconnecting cables including power cables and individual high side power leads. Additionally, non-safety critical equipment that are part of or connected to safety-critical are considered as applicable for this test method. Normally a procurement contract will specify test applicability but consider the design implications if developing a product that potentially fits into the critical category.

What waveforms and test levels apply?

Waveforms associated with CS117 are classified as double exponential or damped sine wave where the waveform generator provides control of the rise and decay times of various waveforms. Figure 1 provides a generic waveform shape. The double exponential waveform on the left has an amplitude in current (I) terms or in voltage (V) terms. T_1 denote the rise time and T_2 denotes the decay time to 50% of the peak. The rise and decay times vary depending on the waveform selected for test with the detailed waveform parameters provided in the standard. The waveform parameters are verified by applying the transient to a calibration loop configured as a short circuit for current (I) waveforms and configured as an open circuit for voltage (V) waveforms.

The damped sine or cosine waveform on the right amplitude is in voltage terms and has a frequency of 1 MHz or 10 MHz with both frequencies used for testing. The dampening factor is not specified but based on the waveform drawing, the 50% ($\pm 25\%$) decay is reached by the 5th cycle.

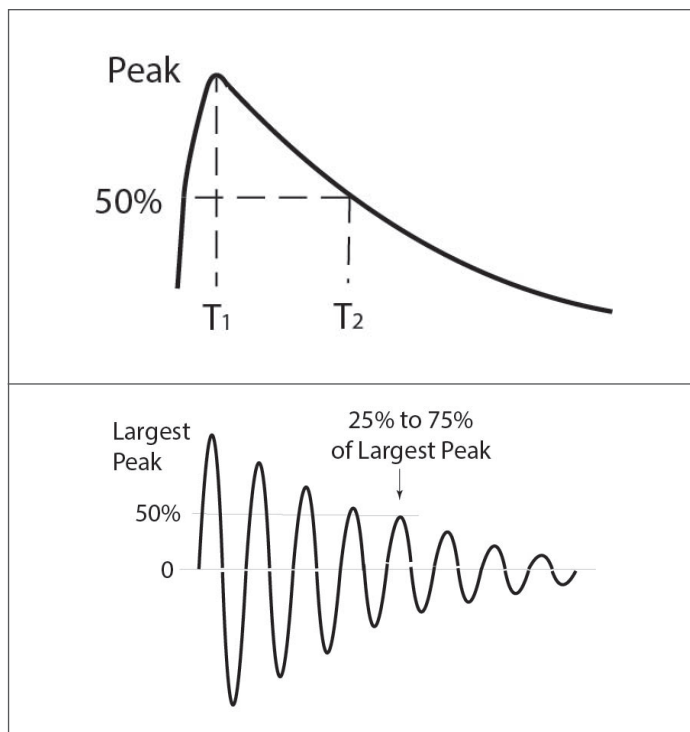

Figure 1: Double Exponential (top) and Damped Sine (bottom) Waveforms

What is a calibration loop?

A low impedance wire loop. Note that impedance is the basis so low self-inductance and low resistance must be considered. High current levels are associated so the wire should be large enough to prevent potential I^2R heating issues. The loop passes through the injection transformer in a single turn with enough length to support injection transformer and monitor probe placement.

What is implied by test level versus limit level?

The test level is the target amplitude for the specific waveform. The waveform calibration verifies that the test level can be produced into the short circuit calibration loop for double-exponential current waveforms or open calibration loop for damped sine voltage waveforms. During test the characteristic cable impedance is not known, so adjusting the amplitude to achieve the test level we may encounter an inability to attain the specified current or voltage. In this case the limit level is used to prevent over-stressing the circuit. We must realize that cable placement can affect the impedance so maintain the test configuration to help with standardization.

Table VII in MIL-STD-461G lists the applicable waveforms and test/limit levels for multiple stroke and multiple burst testing. Single stroke tests are not separately specified but combined into the multiple stroke tests by elevating the first stroke test/limit levels.

The table also sets the test/limit levels for internal and external installation applications. Table VII provides the generic test/limit levels, however if platform data is available the test/limit level should be tailored to use platform specific information.

What are low count wire bundles?

Table VII includes a separate test/limit level for individual power leads or low count wire bundles. The lesser of the individual lead test/limit current multiplied by the number of wires or the specified test/limit level is used. Depending on the waveform and test level, a bundle with as many as 10-wires could be considered as a low count cable. For example, in Table VII 1st row (see Figure 2), the internal first stroke individual I_T is 60 A and bundle I_T is 600 A so a 9-wire bundle would use an I_T of 540 A. If this test level was set, then subsequent strokes would apply 270 A, exceeding the test level prescribed. This issue should be addressed in the test procedure to avoid confusion about the test execution and acceptance of the product.

The standard treats a wire bundle as all wires associated with an interface connector. I somewhat disagree with this standardization when dealing with cable injection testing including the CS117 test method. We need to understand the installation cable layout to determine test levels. Consider that a single interface may have wiring that routes two different directions upon exiting the device – e.g., some wires route to the cockpit control head and other wires route to sensors in the aircraft tail. Coupling exposure is not equal so a common mode current could become differential at the device creating an interference that is not apparent if common mode. A test procedure should address this potential risk and establish appropriate testing.

What about waveform 6 applicability?

MIL-STD-461G, Table VII under the multiple burst heading a discussion regarding waveform 6 with some ambiguity. "Equipment installations that utilize short, low impedance cable bundle installations." "Short" and "low" lack definition so the test procedure needs to document applicability with the criteria used to determine applicability. Some would consider less than 1-meter as short and others may consider less than 20-meters as short – this decision needs to be agreed upon prior to testing instead of obtaining a report rejection.

WAVEFORM CALIBRATION

Waveform calibration is an integral part of the CS117 test method as with most test methods in MIL-STD-461G under

the signal integrity check mantra. The calibration process confirms the ability for the test level to be attained with the test waveform parameters using the calibration loop configured as shorted loop or open loop as applicable for the test level waveform. Referring to Figure 2, you can see that waveform 1 is associated with the test current (not the voltage limit waveform 2) so the shorted loop configuration would be appropriate for the calibration.

Establish the calibration configuration (see Figure 3) with a shorted calibration loop for calibration of the current waveform. Adjust the transient generator settings to the I_T level applicable to the cable to be tested and record the settings and waveform. Verify that the waveform parameters comply with the timing parameters established for that waveform.

It is not necessary for the transient generator to produce the associated V_L limit waveform, however if the transient generator can produce the V_L level in the shorted loop configuration the settings and waveforms should be recorded. Accomplish the calibration process for each applicable waveform recording the settings and waveform parameters. For multiple stroke and multiple burst tests, verify the pulse patterns and timing.

Reverse the transient generator polarity and repeat the calibration process.



Figure 3: Calibration Configuration

Applicability	Test Description	Internal Equipment Levels **	External Equipment Levels **
All equipment installation	Waveform 2 (WF2)/ Waveform 1 (WF1)	First Stroke $V_L = 300\text{ V}$ (WF2) $I_T = 600\text{ A}$ (WF1) $I_T - 60\text{ A}^*$ Subsequent Strokes $V_L = 150\text{ V}$ (WF2) $I_T = 150\text{ A}$ (WF1) $I_T = 30\text{ A}^*$	First Stroke $V_L = 750\text{ V}$ (WF2) $I_T = 1500\text{ A}$ (WF1) $I_T - 150\text{ A}^*$ Subsequent Strokes $V_L = 375\text{ V}$ (WF2) $I_T = 375\text{ A}$ (WF1) $I_T = 75\text{ A}^*$

Figure 2: MIL-STD-461G, Table VII Extract

EUT TESTING

Now that the waveform calibration has been successfully completed, the test configuration can be established and testing can proceed. Figure 4 shows the basic test configuration for signal or control lines. For power line tests, the injection transformer would be installed between the LISNs and the EUT and recall that MIL-STD-461 specifies that the power cable be unshielded and have a length of 2.5-meters for testing.

Once configured, establish EUT operation and allow the EUT to stabilize. Start applying transients with the transient generator adjusted to zero then increase the transient generator amplitude settings or injection transformer configuration until the test level or the limit level is attained. Note that if injection transformer configuration is changed a re-calibration is required. As the amplitude is increased monitor the EUT performance for susceptibility indications.

- If susceptibility is NOT observed the EUT is considered compliant.
- If susceptibility outside the performance requirements is observed the EUT is considered non-compliant.
- If the limit level is attained before the test level is reached an evaluation is used to determine acceptability using the following criteria:
 1. If the transient generator produced a compliant limit level waveform during calibration, the test is acceptable.
 2. If the specified limit level waveform is attained during test and the wave shape meets the parameters, the test is acceptable.
 3. If one of the above criteria is not met, a retest is required using a transient generator that can meet the limit level waveform requirements.

Multiple stroke testing applies at least ten multiple strokes while monitoring EUT performance. The time between multiple stroke applications shall not exceed 5-minutes.

Multiple burst testing applies a multiple burst every 3-seconds for at least 5-minutes while monitoring the EUT for susceptibility indications.

Remember that the testing is repeated with the transient generator polarity reversed.

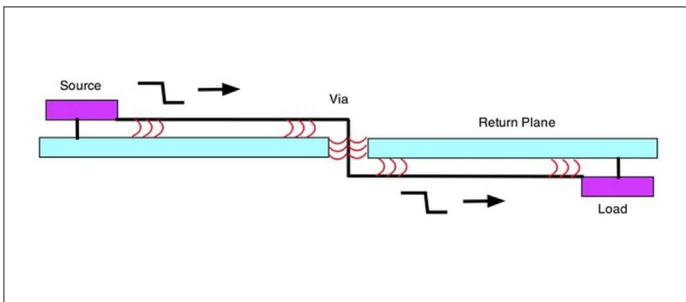

Figure 4: Test Configuration

Note that the standard provides significant guidance on measuring the applied waveforms dealing with RF noise on

the waveform. Since the standard is thorough on this topic, I am not going to repeat that information in this article. The guidance is in the MIL-STD-461G appendix.

Remember that cable placement during test may influence the waveform and provide alternate current paths from parasitic reactance – note the physical parameters and conform to the standard layout – good photos of the configuration provides the ability to repeat the test with minimum variance.

SUMMARY

As we have discussed, planning for this test is essential and that planning includes understanding the installation and platform construction. Understanding the application and test requirements is needed to support inclusion of control measures to prevent susceptibility.

Pay close attention in selecting acceptance criteria for device performance. Failing to allow minor perturbations that do not impair the critical performance can affect the product design and associated costs.

Don't forget that the CS117 testing involves some relatively high current and voltage levels. Maintain a safe test environment to prevent shocking events that can result in injury. Use appropriate personal protective equipment in case the EUT should experience rapid disassembly from high level transients.

The overall test program for CS117 requires many measurement system details so pay attention to the testing,

2021 INDEX OF ADVERTISERS

Request Information From Our Advertisers

When you contact our advertisers, please remember to tell them you saw their ad in *Interference Technology*.



A.H. Systems
 9710 Cozycroft Ave
 Chatsworth, CA 91311
t: (818) 998-0223
e: sales@ahsystems.com
w: www.AHSystems.com
page: C2



AR RF/Microwave Instrumentation
 160 School House Rd.
 Souderton, PA 18964
t: (215) 723-8181
e: info@arworld.us
w: www.arworld.us
page: 7



Coilcraft Inc.
 1102 Silver Lake Road
 Cary IL 60013
t: (800) 322-2645
e: sales@coilcraft.com
w: www.coilcraft.com
pages: 144, 167



EMC LIVE
 1000 Germantown Pike
 Plymouth Meeting, PA 19462
t: (484) 688-0300
w: https://emc.live/
e: james@lectrixgroup.com
pages: 104, 154



Exodus Advanced Communications
 3674 East Sunset Road, Suite 100
 Las Vegas, NV 89120
t: (702) 534-6564
e: sales@exoduscomm.com
w: www.exoduscomm.com
page: C3



Fair-Rite Products Corp.
 PO Box 288
 One Commercial Row
 Wallkill, NY 12589
t: (888) 324-7748
e: ferrites@fair-rite.com
w: www.fair-rite.com
page: 44



Interference Technology
 1000 Germantown Pike
 Plymouth Meeting, PA 19462
t: (484) 688-0300
e: james@lectrixgroup.com
w: www.interferencetechnology.com
pages: C4



LECTRIX
 1000 Germantown Pike
 Plymouth Meeting, PA 19462
t: (484) 688-0300
e: james@lectrixgroup.com
w: www.lectrixgroup.com
pages: 1



R&K Company Limited
 721-1 Maeda, Fuji-city, Shizuoka
 416-8577 JAPAN
t: +81-545-31-2600
e: info@rkco.jp
w: www.rk-microwave.com/index.php
page: 76



Spira
 650 Jessie Street
 San Fernando, CA 91340
t: (818) 764-8222
e: info@spira-emi.com
w: www.spira-emi.com
page: 27



Schaffner EMC, Inc
 52 Mayfield Avenue
 Edison NJ, 08837, U.S
t: (800) 367-5566
e: usasales@schaffner.com
w: www.schaffnerusa.com
page: 39

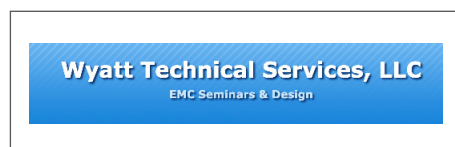

Wyatt Technical Services, LLC
 56 Aspen Dr.
 Woodland Park, CO 80863
t: (484) 688-0300
e: ken@emc-seminars.com
w: www.emc-seminars.com
pages: 98

Call for Authors and Contributors!

Want to be a part of the next issue of Interference Technology? Have an article or blog post you'd like to write for InterferenceTechnology.com?

Please Contact James Marengo at
james@lectrixgroup.com



www.InterferenceTechnology.com