

PRESENTED BY

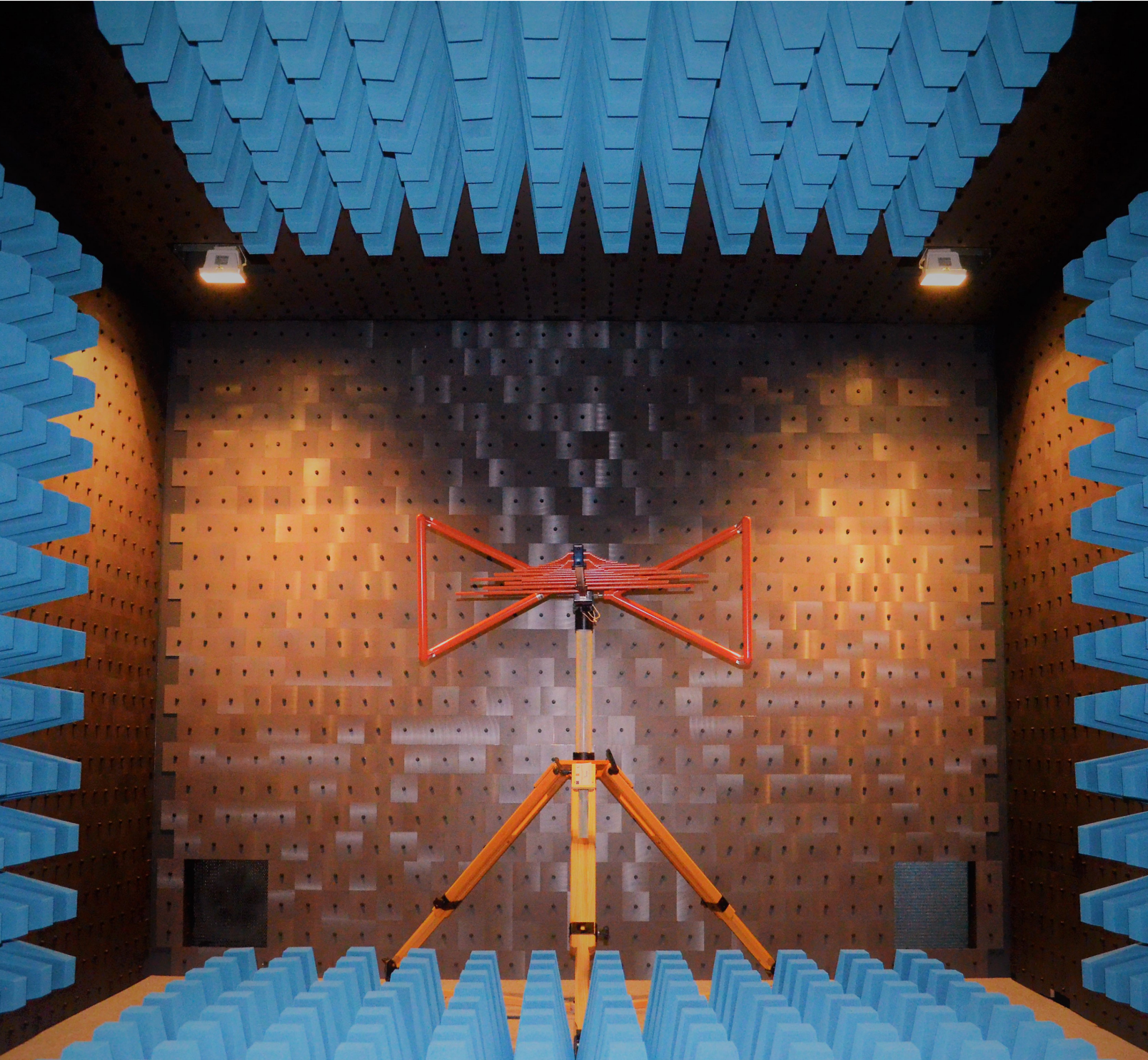

# 2018 EMC TESTING GUIDE





# Catch them because you can. With the new flagship in EMI testing.

The new R&S®ESW EMI test receiver catches them all, the spikes and other disturbances that may show up in your DUT. Thanks to its unrivalled dynamic range, its ultrafast FFT-based time domain scan and realtime spectrum analysis, there is no way to escape its analysis power. For certification or lab tasks – this is the instrument you can totally rely on.

Get the details: [www.rohde-schwarz.com/ad/esw](http://www.rohde-schwarz.com/ad/esw)





# TABLE OF CONTENTS

|                                                                                        |          |
|----------------------------------------------------------------------------------------|----------|
| <b><i>EMC Equipment Manufacturers</i></b>                                              | <b>6</b> |
| Summary of Commercial EMC Tests<br>GHERY PETTIT                                        | 9        |
| Summary of Military and<br>Aerospace EMC Tests<br>GHERY PETTIT                         | 14       |
| EMI Troubleshooting With<br>Real-Time Spectrum Analyzers<br>KENNETH WYATT              | 20       |
| UNECE Regulation 10:<br>The Type Approval Process<br>SPONSORED BY: AMETEK              | 26       |
| Troubleshooting EFT<br>AZIZ YULDASHEV                                                  | 30       |
| Measuring Common Mode Versus<br>Differential Mode Conducted Emissions<br>KENNETH WYATT | 34       |

## REFERENCE SECTION

|                                                                                  |    |
|----------------------------------------------------------------------------------|----|
| Common Commercial EMC Standards                                                  | 38 |
| Military Related Documents & Standards                                           | 43 |
| Automotive Electromagnetic<br>Compatibility (EMC) Standards                      | 45 |
| Useful EMC Testing References<br>(directory, books, journals, formulas & tables) | 48 |
| EMC and Design Conferences 2018-2019                                             | 50 |
| Index of Advertisers                                                             | 51 |



# INTRODUCTION



## Kenneth Wyatt

Senior Technical Editor, *Interference Technology*

Thanks for downloading the 2018 EMC Testing Guide from Interference Technology! We hope you find it a valuable addition to your EMC and product design tools.

Electromagnetic compatibility (EMC) and the related electromagnetic interference (EMI) seems to be one of those necessary evils that must be overcome prior to marketing commercial or consumer electronic products, as well as military and aerospace equipment. Unfortunately, few universities and colleges teach this important information, with the result that products are rarely designed to meet EMC/EMI requirements. EMC or EMI compliance is often left to the end of a project with all the associated schedule delays and unplanned project cost.

The purpose of Interference Technology's 2018 EMC Testing Guide is to help product designers learn enough of the basics of EMC testing, as well as (in-house) pre-compliance testing so that the usual design issues are addressed early when costs and design change is minimized. Achieving EMC/EMI is a lot easier once the design basics and EMC tests are understood.

Today, with all the myriad of electronic products, including wireless and mobile devices, compatibility between devices is becoming even more important. Products must not interfere with one another (radiated or conducted emissions) and they must be designed to be immune to external energy sources, such as external transmitters and ESD. Most countries now impose some sort of EMC standards to which products must be tested.

The old mantra, "Test Early - Test Often" is an important consideration for successful EMC compliance. There are many quick emissions and immunity tests that may be performed right on the workbench, that will help identify "red flags" early in the design.

Radiated emissions is often the leading failure during compliance testing and simple test setups made in-house can help identify harmonics that are over the limit quickly and less expensively than performing troubleshooting at the compliance test facility.

This year's 2018 EMC Testing Guide includes articles on how to establish a simple pre-compliance test capability, summaries of commercial and military EMC standards, troubleshooting electrically fast transient (EFT), the type approval process for the automotive UN ECE Regulation 10 standard, and measuring common mode versus differential mode harmonic currents. We also provide additional links to several other valuable testing and troubleshooting articles.

We at Interference Technology hope this 2018 EMC Testing Guide provides you some valuable tools for reducing the cost of EMC compliance testing. Feel free to provide some feedback as to any other subjects you'd like to see us cover.

**Cheers,**

Ken | [kwyatt@interferencetechnology.com](mailto:kwyatt@interferencetechnology.com)



# AR EMC Systems Are Only Matched By Our Support



Any system is only as good as the support and service you receive before, during and after delivery. We provide the best support and service in the industry to insure that any AR radiated or conducted immunity or emission system exceeds your requirements to give you easy, trouble free operation. We worry about every detail so you don't have to. From cabinet shielding and wiring harnesses to the bolts and screws for the final assembly. And did we mention free automated test software to make testing easier, faster, and more accurate than ever?

Additional reasons to only specify AR EMC systems are:

- Performance guarantee - AR manufactures the critical components for each system
- Entire system fully tested before leaving facility & upon installation
- Single source for service and support
- Radiated Immunity test systems to 50 GHz with high field strengths
- Conducted Immunity systems from 4 kHz to 3 GHz
- Emission systems to 40 GHz
- Built to meet numerous standards including IEC, CISPR, MIL-STD-461/464, DO-160, ISO, Wireless, HIRF, & HERO

To learn more, visit [www.arworld.us/systems](http://www.arworld.us/systems) or call us at 215-723-8181.

ISO 9001:2015  
Certified

We don't just build great products.  
We build great products that last.



## rf/microwave instrumentation

Other **ar** divisions: modular rf • sunar rf motion • receiver systems • ar europe

USA 215-723-8181. For an applications engineer, call 800-933-8181.

In Europe, call ar United Kingdom +44 1908 282766 • ar France +33147917530 • ar Deutschland +49 6101 80270 0 • ar Benelux +31 172 423000

[www.arworld.us](http://www.arworld.us)  
Download the AR RF/Microwave Mobile App: [www.arworld.us/arApp](http://www.arworld.us/arApp)

Copyright © 2018 AR.

The orange stripe on AR products is  
Reg. U.S. Pat. & TM. Off.



# EMC EQUIPMENT MANUFACTURERS

---

## Introduction

The following chart is a quick reference guide of test equipment and includes everything you'll need from the bare minimum required for key evaluation testing, probing, and troubleshooting, to setting up a full in-house precompliance or full compliance test lab. The list includes amplifiers, antennas, current probes, ESD simulators, LISNs, near field probes, RF signal generators, spectrum analyzers, EMI receivers, and TEM cells. Equipment rental companies are also listed. The products listed can help you evaluate radiated and conducted emissions, radiated and conducted immunity and a host of other immunity tests, such as ESD and EFT.

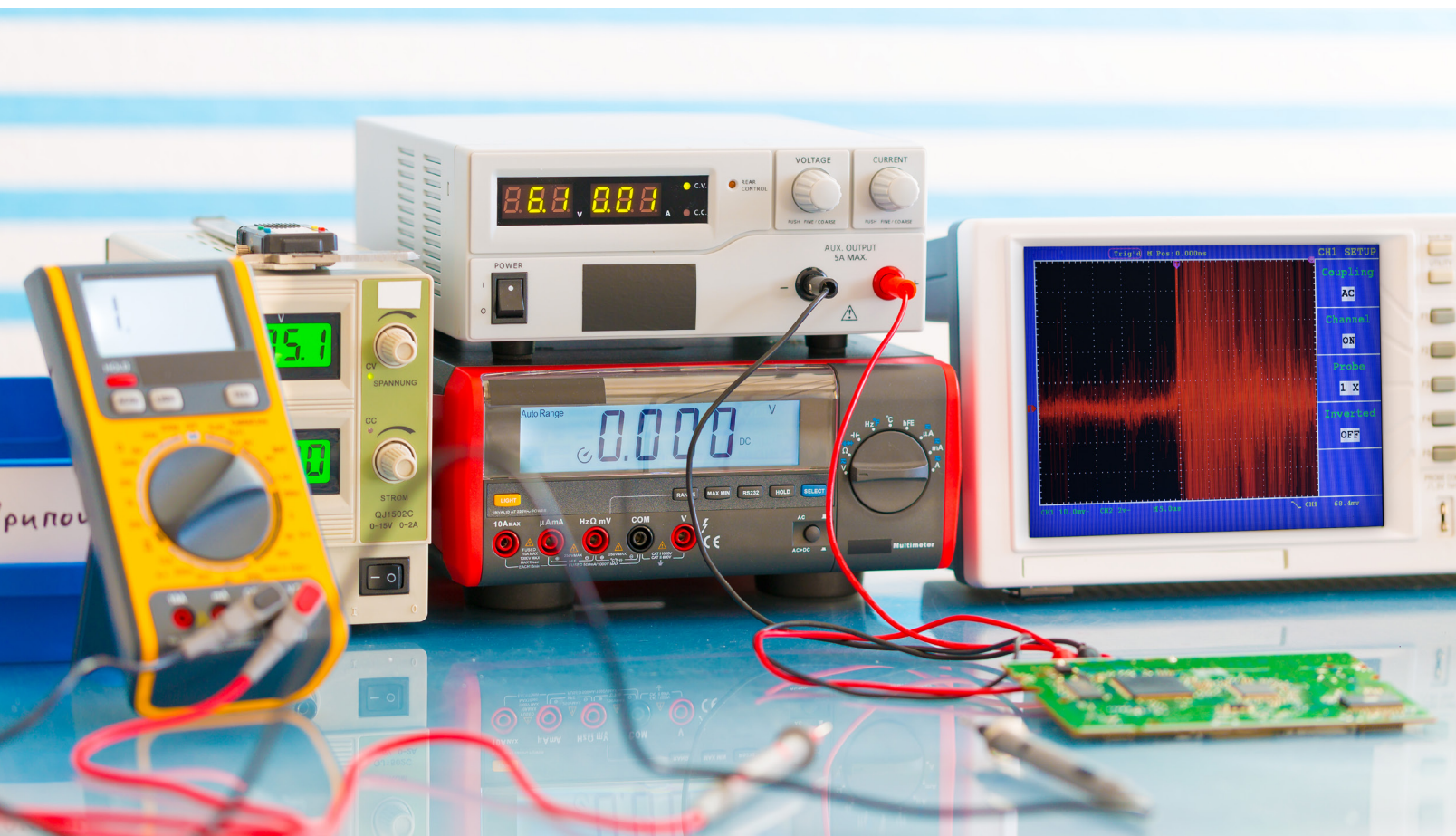



| EMC Equipment Manufacturers     |                                                                                                                                                 | Type of Product/Service |            |                   |                |                                  |                |       |                   |                    |                     |           |                  |                      |
|---------------------------------|-------------------------------------------------------------------------------------------------------------------------------------------------|-------------------------|------------|-------------------|----------------|----------------------------------|----------------|-------|-------------------|--------------------|---------------------|-----------|------------------|----------------------|
| Manufacturer                    | Contact Information - URL                                                                                                                       | Antennas                | Amplifiers | Near Field Probes | Current Probes | Spectrum Analyzers/EMI Receivers | ESD Simulators | LISNs | Radiated Immunity | Conducted Immunity | Pre-Compliance Test | TEM Cells | Rental Companies | RF Signal Generators |
| A.H. Systems                    | <a href="http://www.ahsystems.com">http://www.ahsystems.com</a>                                                                                 | X                       | X          |                   | X              |                                  |                |       |                   |                    | X                   |           |                  |                      |
| Aaronia AG                      | <a href="http://www.aaronia.com">http://www.aaronia.com</a>                                                                                     | X                       | X          |                   |                | X                                |                |       |                   |                    | X                   |           |                  |                      |
| Advanced Test Equipment Rentals | <a href="http://www.atecorp.com/category/emc-compliance-esd-rf-emi.aspx">http://www.atecorp.com/category/emc-compliance-esd-rf-emi.aspx</a>     | X                       | X          |                   |                | X                                | X              | X     | X                 | X                  | X                   |           | X                | X                    |
| AR RF/Microwave Instrumentation | <a href="https://www.arworld.us">https://www.arworld.us</a>                                                                                     | X                       | X          |                   |                | X                                |                | X     | X                 | X                  | X                   |           |                  | X                    |
| Anritsu                         | <a href="http://www.anritsu.com">http://www.anritsu.com</a>                                                                                     |                         |            |                   |                | X                                |                |       |                   |                    | X                   |           |                  | X                    |
| Electro Rent                    | <a href="http://www.electrorent.com">http://www.electrorent.com</a>                                                                             |                         | X          |                   |                | X                                | X              | X     | X                 | X                  | X                   |           | X                | X                    |
| EM Test                         | <a href="http://www.emtest.com/home.php">http://www.emtest.com/home.php</a>                                                                     |                         |            |                   |                |                                  |                |       |                   | X                  | X                   | X         |                  |                      |
| EMC Partner                     | <a href="https://www.emc-partner.com">https://www.emc-partner.com</a>                                                                           |                         |            |                   |                |                                  | X              |       |                   | X                  |                     |           |                  |                      |
| Empower RF Systems              | <a href="http://www.empowerrf.com">http://www.empowerrf.com</a>                                                                                 |                         | X          |                   |                |                                  |                |       | X                 |                    |                     |           |                  |                      |
| Gauss Instruments               | <a href="https://www.gauss-instruments.com/en/">https://www.gauss-instruments.com/en/</a>                                                       |                         |            |                   |                | X                                |                |       |                   |                    |                     |           |                  |                      |
| Haefely-Hipotronics             | <a href="http://www.haefely-hipotronics.com">http://www.haefely-hipotronics.com</a>                                                             |                         |            |                   |                |                                  | X              |       |                   | X                  |                     |           |                  |                      |
| Instrument Rental Labs          | <a href="http://www.testequip.com">http://www.testequip.com</a>                                                                                 |                         | X          |                   |                | X                                | X              | X     | X                 | X                  | X                   |           | X                | X                    |
| Instruments For Industry (IFI)  | <a href="http://www.ifi.com">http://www.ifi.com</a>                                                                                             |                         | X          |                   |                |                                  |                |       | X                 | X                  |                     |           |                  |                      |
| Kent Electronics                | <a href="http://www.wa5vjb.com">http://www.wa5vjb.com</a>                                                                                       | X                       |            |                   |                |                                  |                |       |                   |                    |                     |           |                  |                      |
| Keysight Technologies           | <a href="http://www.keysight.com/main/home.jsp?cc=US&amp;lc=eng">http://www.keysight.com/main/home.jsp?cc=US&amp;lc=eng</a>                     |                         |            | X                 |                | X                                |                | X     |                   |                    | X                   |           |                  | X                    |
| Microlease                      | <a href="https://www.microlease.com/us/home">https://www.microlease.com/us/home</a>                                                             |                         | X          |                   |                | X                                | X              | X     | X                 | X                  | X                   |           | X                | X                    |
| Milmega                         | <a href="http://www.milmega.co.uk">http://www.milmega.co.uk</a>                                                                                 |                         | X          |                   |                |                                  |                |       | X                 | X                  |                     |           |                  |                      |
| Narda/PMM                       | <a href="http://www.narda-sts.it/narda/default_en.asp">http://www.narda-sts.it/narda/default_en.asp</a>                                         | X                       | X          |                   |                | X                                |                | X     | X                 | X                  | X                   |           |                  |                      |
| Noiseken                        | <a href="http://www.noiseken.com">http://www.noiseken.com</a>                                                                                   |                         |            |                   |                |                                  | X              |       |                   | X                  | X                   |           |                  |                      |
| Ophir RF                        | <a href="http://ophirrf.com">http://ophirrf.com</a>                                                                                             |                         | X          |                   |                |                                  |                |       |                   | X                  |                     |           |                  |                      |
| Pearson Electronics             | <a href="http://www.pearsonelectronics.com">http://www.pearsonelectronics.com</a>                                                               |                         |            |                   | X              |                                  |                |       |                   |                    |                     |           |                  |                      |
| Rigol Technologies              | <a href="https://www.rigolna.com">https://www.rigolna.com</a>                                                                                   |                         |            | X                 | X              | X                                |                |       |                   |                    | X                   |           |                  | X                    |
| Rohde & Schwarz                 | <a href="https://www.rohde-schwarz.com/us/home_48230.html">https://www.rohde-schwarz.com/us/home_48230.html</a>                                 | X                       | X          | X                 | X              | X                                |                | X     | X                 | X                  | X                   |           |                  | X                    |
| Siglent Technologies            | <a href="http://siglentamerica.com">http://siglentamerica.com</a>                                                                               |                         |            | X                 |                | X                                |                |       |                   |                    | X                   |           |                  | X                    |
| Signal Hound                    | <a href="https://signalhound.com">https://signalhound.com</a>                                                                                   |                         |            | X                 |                | X                                |                |       |                   |                    | X                   |           |                  | X                    |
| TekBox Technologies             | <a href="https://www.tekbox.net">https://www.tekbox.net</a>                                                                                     |                         | X          | X                 |                |                                  |                | X     |                   |                    | X                   | X         |                  |                      |
| Tektronix                       | <a href="http://www.tek.com">http://www.tek.com</a>                                                                                             |                         |            | X                 |                | X                                |                |       |                   |                    | X                   |           |                  |                      |
| Teseq                           | <a href="http://www.teseq.com/en/index.php">http://www.teseq.com/en/index.php</a>                                                               |                         | X          |                   | X              |                                  | X              |       | X                 | X                  | X                   | X         |                  |                      |
| Test Equity                     | <a href="https://www.testequity.com/leasing/">https://www.testequity.com/leasing/</a>                                                           |                         | X          |                   |                | X                                | X              | X     | X                 | X                  | X                   |           | X                | X                    |
| Thermo Keytek                   | <a href="https://www.thermofisher.com/us/en/home.html">https://www.thermofisher.com/us/en/home.html</a>                                         |                         |            |                   |                |                                  | X              |       |                   | X                  |                     |           |                  |                      |
| Thurlby Thandar (AIM-TTi)       | <a href="http://www.aimtti.us">http://www.aimtti.us</a>                                                                                         |                         |            |                   |                | X                                |                |       |                   |                    | X                   |           |                  | X                    |
| Toyotech (Toyo)                 | <a href="https://toyotechus.com/emc-electromagnetic-compatibility/">https://toyotechus.com/emc-electromagnetic-compatibility/</a>               | X                       | X          |                   |                | X                                |                | X     | X                 |                    | X                   |           |                  |                      |
| TPI                             | <a href="http://www.rf-consultant.com">http://www.rf-consultant.com</a>                                                                         |                         |            |                   |                |                                  |                |       |                   |                    |                     |           |                  | X                    |
| Transient Specialists           | <a href="http://www.transientspecialists.com">http://www.transientspecialists.com</a>                                                           |                         |            |                   |                |                                  |                |       | X                 | X                  |                     | X         |                  |                      |
| TRSRentelCo                     | <a href="https://www.trs-rentelco.com/SubCategory/EMC_Test_Equipment.aspx">https://www.trs-rentelco.com/SubCategory/EMC_Test_Equipment.aspx</a> | X                       | X          |                   |                | X                                |                | X     | X                 | X                  | X                   |           | X                | X                    |
| Vectawave Technology            | <a href="http://vectawave.com">http://vectawave.com</a>                                                                                         |                         | X          |                   |                |                                  |                |       |                   |                    |                     |           |                  |                      |
| Windfreak Technologies          | <a href="https://windfreaktech.com">https://windfreaktech.com</a>                                                                               |                         |            |                   |                |                                  |                |       |                   |                    |                     |           |                  | X                    |



# Your one stop for EMC Testing services

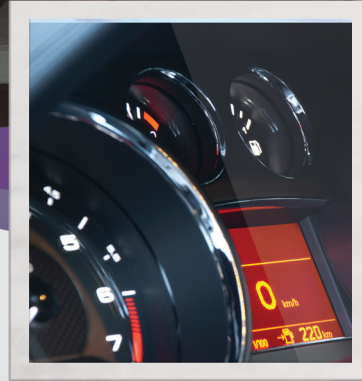
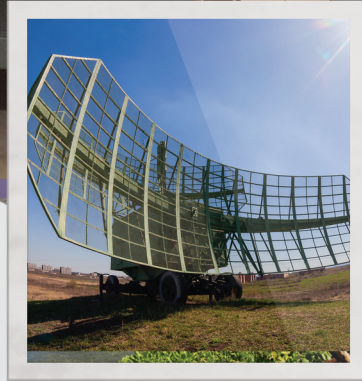
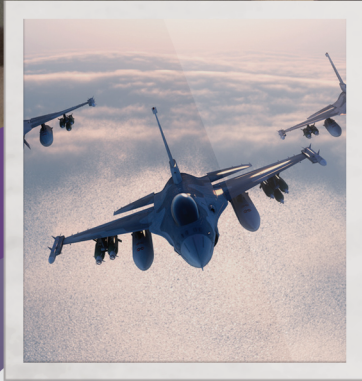
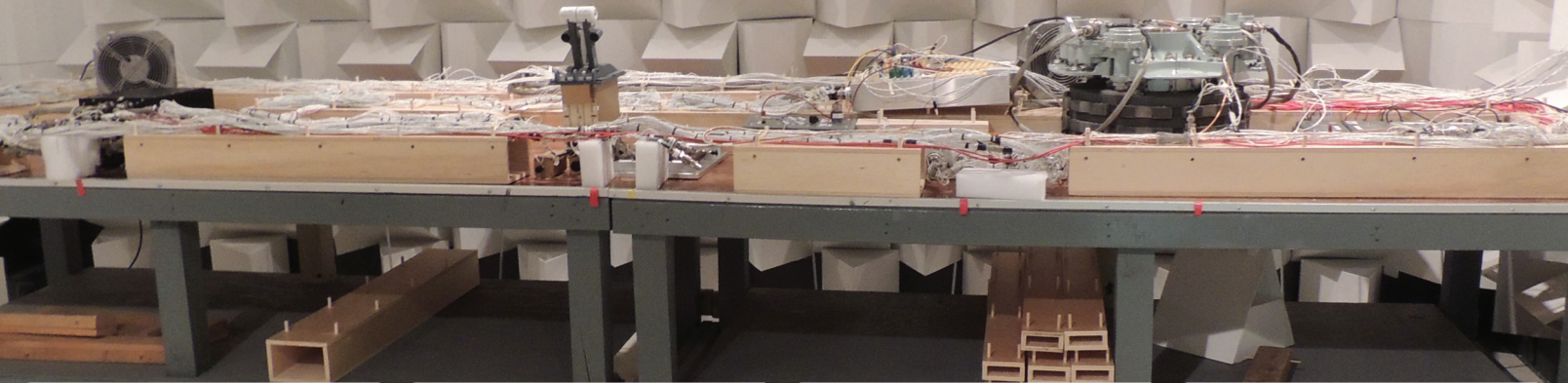

R&B Laboratory, a NVLAP accredited to ISO-17025 located outside Philadelphia, PA provides certified EMC testing and reports for Military, Avionics and Automotive applications. R&B is also capable of offering EMI solutions for non-compliance products. Our highly skilled technicians and engineers work closely with clients to fulfill their testing needs. The Laboratory facility includes 8 semi-anechoic shielded rooms and a reverberation chamber, each equipped with multiple power capabilities and automated data acquisition.

## CAPABILITIES

### EMC Testing and Engineering Support

- Military (MIL-STD-461, MIL-STD-704 and MIL-STD-1399)
- Aerospace (RTCA/DO-160, Boeing and Airbus)
- Automotive (SAE, ISO, Fiat Chrysler, Ford, and GM)
- CISPR / FDA
- Reverberation Chamber (HIRF)
- System Engineering Support
- Detail Design Support for EMC compliance
- Test Procedures / Control Plans
- Site Surveys
- NVLAP accreditation to ISO-17025

# SUMMARY OF COMMERCIAL EMC TESTS

---

**Ghery Pettit**

Pettit EMC Consulting

Ghery@PettitEMCConsulting.com

## **Introduction**

*Commercial EMC tests cover a wide range of products. These include the obvious ones like computers and their peripherals, but also cover household appliances, electric tools and a wide variety of other products. While the standards, including limits and test methods may differ, all EMC test standards have a few things in common. The most basic are the limits for emissions and the types and levels of immunity testing.*

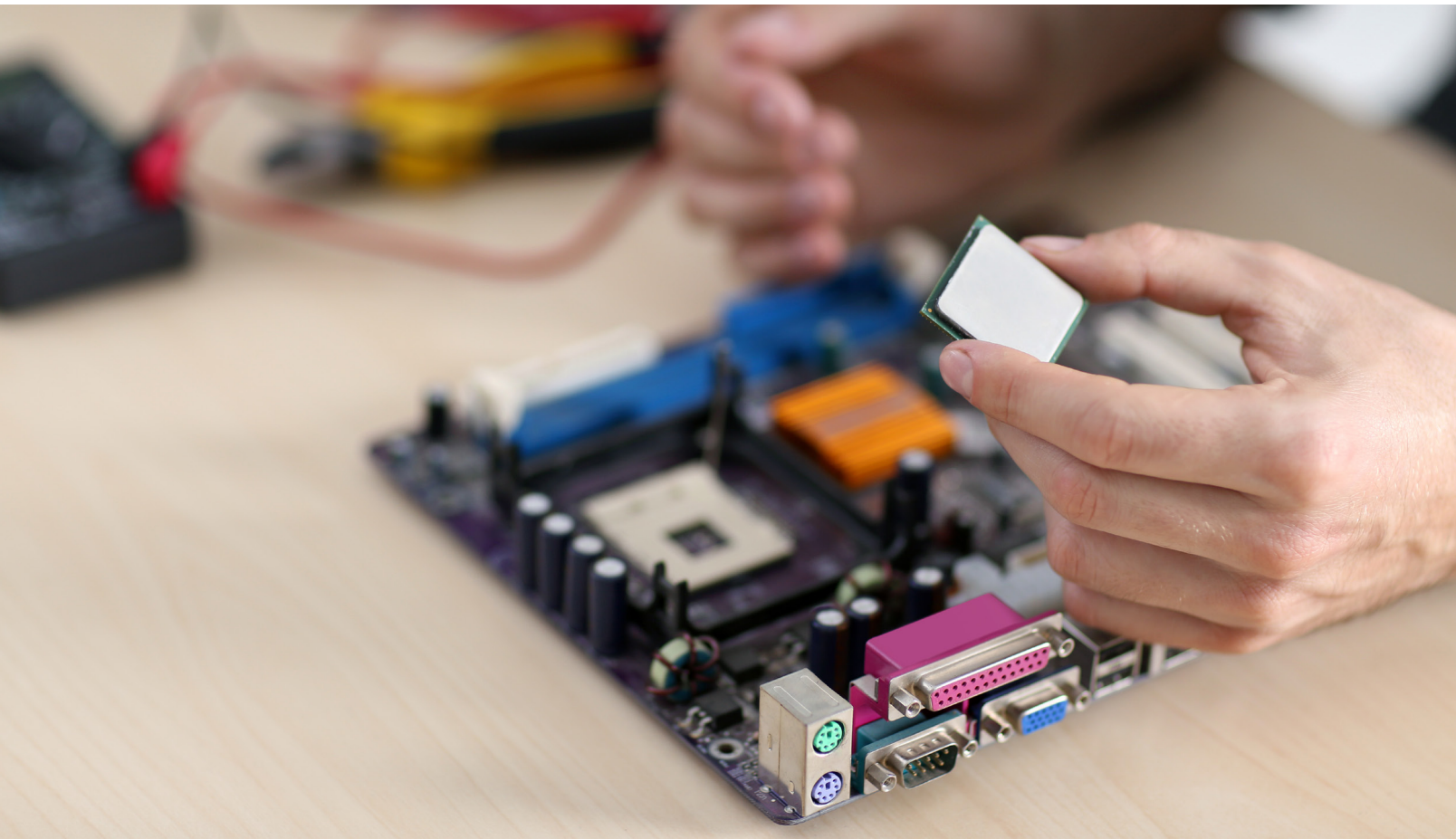



## SUMMARY OF COMMERCIAL EMC TESTS

Emissions tests (and their associated limits) are put in place for commercial equipment primarily to protect radio and television broadcasting services. Other radio communications services are also protected. While a very few commercial emissions standards existed prior to the introduction of the personal computer to the marketplace, the proliferation of these devices spurred the development of standards and regulations around the world due to the large number of interference complaints directly traceable to these new devices. Early personal computing devices were designed and built with no regard to controlling radio frequency emissions and, as a result, they generated large amounts of RF emissions. Indeed, it could be argued that the early personal computing devices were broadband radio transmitters masquerading as computers. Mainframe computers had similar weaknesses, but as they typically weren't installed in residential areas the impact was smaller.

Emissions testing typically comprises of two parts. Conducted emissions on power and telecommunications ports and radiated emissions. The breakpoint between the two (conducted and radiated) in commercial standards is 30 MHz. This frequency was chosen as at the typical test distances involved (3 meters and 10 meters today) frequencies above 30 MHz tend to provide plane wave (far field) emissions, allowing for fairly repeatable measurements from laboratory to laboratory. Below 30 MHz this may not be the case. Thus, conducted emissions are measured. Limits for powerline conducted emissions were set based on the source and victim devices being connected to the same circuit. Limits for conducted emissions on telecommunication ports are set assuming a certain conversion of the differential mode (desired) signals on the cable being converted to common mode (due to characteristics of the cable) which then radiates.

### Conducted Emissions

Conducted emissions on the incoming power lines are measured (typically) using a Line Impedance Stabilization Network (LISN) or Artificial Mains Network (AMN). These are two different names for the same box. The LISN or AMN is placed between the Equipment Under Test (EUT) and the incoming power line (mains) to provide a defined power line impedance and a coupling point to the receiver (*Figure 1*). The LISN or AMN is placed on the horizontal ground plane, or directly beneath it with the EUT connected directly to the EUT port. The block diagram below shows this test setup.

The EUT is placed either on the horizontal ground plane on the floor (with an insulating spacer) or on an 80 cm high non-conducting table, depending on the intended installation of the EUT (table top or ground mounted). The frequency range of interest is scanned with the appropriate detectors and bandwidth and the results are not-

ed. Measurement are made on each conductor of the incoming line separately. Most commercial EMC standards have measurements made over the frequency range of 150 kHz to 30 MHz.

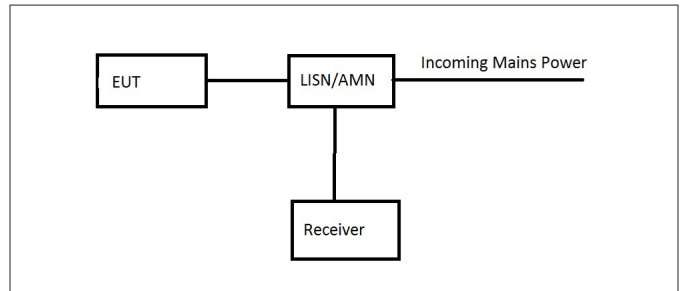

Figure 1 - Generalized test setup for conducted emissions using a line impedance stabilization network (LISN).

### Radiated Emissions

Radiated emissions may be measured in either an Open Area Test Site (OATS) or an RF Semi-Anechoic Chamber (SAC). The OATS is the “gold standard” test facility. It consists of a large open area free of objects which might reflect RF energy. It typically is equipped with a reflecting ground plane. The size of the clear area is defined in various standards as an elliptical area whose major axis is twice the measurement distance and whose minor axis is the square root of 3 times the measurement distance. Experience has shown over the decades that these dimensions are too small. Doubling them has been tried and even that has been shown to have its weaknesses, especially when the OATS is surrounded by a chain link fence for security. The picture below shows a 30 meter OATS built in 1989 for Tandem Computers Incorporated near Hollister, California. The clear area is at least twice the required dimensions for a 30 meter site and takes a considerable amount of land. This site is no longer in operation, but it illustrates the point. The building on the ground plane was constructed of RF transparent material and covered the turntable. All utilities were run underground, including the air conditioning ducts with the air conditioning units being installed outside the clear area. The site was never utilized at a measurement distance of 30 meters, so it was a superb 10 meter site.



Figure 2 - A typical open area test site (OATS).

A significant weakness of the OATS facility is that in addition to measuring the emissions from the EUT it is a great facility to measure all the local RF ambient signals from broadcast and communications services, as well. If these signals are strong enough they will totally mask the emissions from the EUT that you were trying to measure. As a result, for best operation an OATS must be located in a very remote area. And this is no guarantee that the ambient level will remain low. Apple Computer had a great OATS near Pescadero, California that had a very low ambient when it was built in the 1980s. Apple ultimately stopped using the facility when the local ambient signals grew to the point where operation was no longer possible and moved totally to 10 meter SACs near their development facilities.

Regardless of whether measurement are taken at an OATS or in a SAC, the block diagram of the test set-up remains the same. Emissions from the EUT are measured using an antenna for the appropriate frequency range, a pre-amplifier (if necessary) and a measuring receiver. Measurements are taken with the antenna in both the vertical and horizontal polarities. See the block diagram in *Figure 3*.

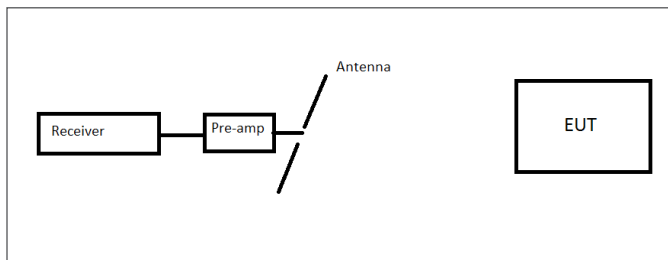

Figure 3 - General test setup for radiated emissions testing.

The need for height scans is shown by the diagram in *Figure 4*. The objective is to adjust the antenna height until the direct and reflected signals are maximized. An example of an antenna mast for this purpose is shown in the photograph above of the Tandem 30 meter OATS (*Figure 2*).

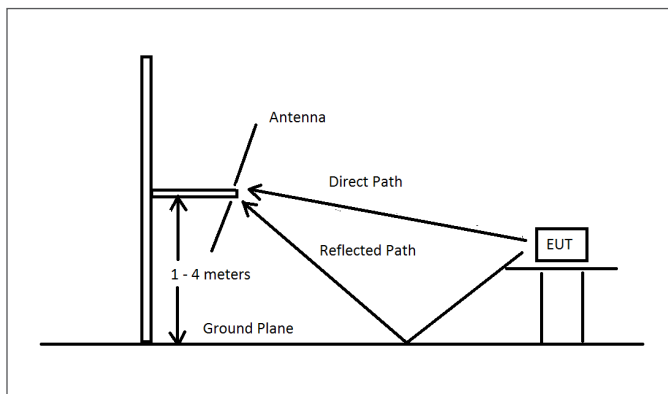

Figure 4 - Diagram showing the direct and reflected waves. The antenna height is adjusted to maximize the measurement.

Emissions tests are required in many countries around the world. Immunity testing of commercial products is re-

quired in a smaller number of countries, but these are some major countries, so a manufacturer must be aware of them.

### Commercial Immunity Tests

Commercial immunity testing typically covers the following types of tests:

#### 1. Electrostatic Discharge (ESD)

There are two types of ESD tests – contact discharge and air discharge. In the contact discharge test the tip of the ESD simulator is placed on the test point of the EUT and the discharge is initiated. The discharge occurs inside the simulator and these tests are fairly repeatable. In the air discharge test the simulator is charged to the specified voltage and brought into contact with the EUT. The discharge, if it occurs, happens before contact is made jumping the air gap between the tip of the simulator and the EUT. How large this gap is depends of the atmospheric pressure, temperature, angle of approach, and relative humidity. It can also depend on how fast the operator approaches the EUT with the ESD gun. Air discharge testing is not as repeatable, but it simulates a different ESD event. Both types of tests are typically required. For computer equipment CISPR 24 requires a contact discharge test at 4 kV and air discharge tests up to 8 kV. Tests are typically performed using the equipment and procedures called out in IEC 61000-4-2. The EUT is allowed to react to the test, but it must self-recover after the test. A classic example is a computer playing music over a speaker. You hear a POP! in the speaker when the ESD event occurs, but the music keeps playing afterwards. This is considered a pass. If the music stopped and required operator intervention to re-start, that would be considered a failure.

#### 2. Radiated electric field immunity

This tests the immunity of the EUT to nearby radio transmitters. The frequency range of 80 MHz to 1 GHz is typically tested, although newer standards have tests required as high as 6 GHz. This test is performed in a fully anechoic chamber or a SAC with removable absorbers placed on the floor. Signal levels are used that would annoy the neighbors and cause the local regulators to issue fines, so a shielded environment is a necessity. The current requirements in IEC 61000-4-3 (a commonly used basic standard) call for the E-field to be uniform within certain requirements before the EUT is brought into the test volume. Four sides of the EUT are typically evaluated. The EUT typically must continue to operate through the test as though nothing was happening to it or must self-recover with no loss of data to be considered a pass.

#### 3. Electrical Fast Transients

This test introduces a series of rapid pulses into the EUT through the power and any signal lines that could exceed 3 meters in length. Like ESD testing, the EUT must operate after the test without operator intervention, but



may react to the test as it occurs, so long as the system self-recovers with no loss of data. IEC 61000-4-4 calls out the test equipment and procedures for this test.

#### 4. Electric Surge

This test simulates what happens on the power input to the EUT when there is a nearby lightning strike. High energy surges are applied to the EUT line input. IEC 61000-4-5 details the test equipment and procedures for performing surge testing.

#### 5. Conducted RF

In commercial standards the breakpoint between conducted RF and radiated RF immunity testing is typically 80 MHz. Generating uniform fields much below 80 MHz is difficult. As a result, below that frequency RF energy is typically injected onto cables connected to the EUT. An example of a block diagram for such a test is shown in *Figure 5*. The 6 dB attenuator is placed as close to the Coupling Decoupling Network (CDN) as possible. While this isn't clearly shown in IEC 61000-4-6, the reason for placing it as close to the CDN as possible is that it provides a matching impedance to the transmission line, maximizing power transfer to the CDN, whose input impedance is not precisely known. Otherwise, you may be throwing away half the power you paid to generate.

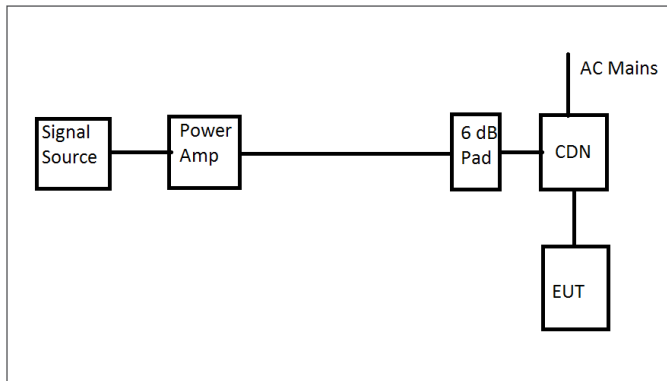

Figure 5 - Typical test setup for the conducted immunity test.

The typical frequency range for conducted RF immunity testing of commercial equipment is 150 kHz to 80 MHz.

#### 6. Power Frequency Magnetic Fields

This test is run for products which might reasonably be expected to have immunity problems with power frequency magnetic fields. Such products, as called out in CISPR 24 for example, might include Cathode Ray Tube (CRT) displays, magnetic field sensors and Hall devices. The EUT is placed in the middle of a large coil of wire through which a power frequency current flows. The current level to generate the specified field level (for example, 1 Amp/meter in CISPR 24) is run through the coil and the EUT is checked for proper operation. All three axes are tested. Most products do not require this test, but it is included in the product family standards. IEC 62000-4-8 details how to perform this test.

#### 7. Dips and dropouts

This test is designed to simulate real world examples of momentary input power voltage fluctuations. In the case of CISPR 24 (and CISPR 35) there are three tests that are performed, typically by a computerized power source. The first is a >95% voltage reduction for one half cycle of the incoming power. The voltage change occurs at the zero crossover point on the power waveform. This simply means that one half cycle of the incoming power to the EUT is chopped off. The EUT is allowed to react, but must self-recover without operator intervention. The second test is a 30% reduction (70% residual voltage) for one half second (25 cycles at 50 Hz or 30 cycles at 60 Hz) - a short brown-out. Again, the EUT may react, but must self-recover. The third commonly used test is a >95% reduction in input voltage for 5 seconds. It's like the power cord was pulled out of the wall socket for 5 seconds and then plugged back in. Obviously, unless the EUT has a built in battery or UPS, it will crash. As long as function can be restored by the operator in accordance with the instructions and no data protected by battery back-up is lost or damaged, the EUT passes this test. IEC 61000-4-11 provides the details on how these tests are to be run.

The test levels utilized in commercial immunity tests are designed to provide a reasonable level of certainty that the product will operate in its intended environment. They do not represent the worst case that a product might experience in the field, but they have been shown over the years to be adequate. Indeed, most products exhibit higher levels of immunity that required when tested to their breaking point and the design features used to meet the emissions requirements typically are adequate for providing this level of immunity.

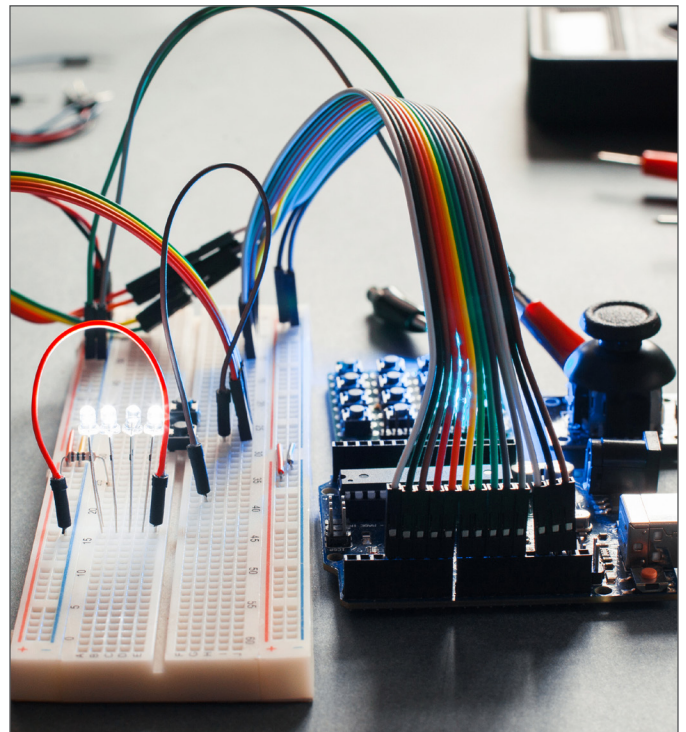

# Does your antenna supplier do *all* this?



|                                         | Your Supplier | A.H. Systems |
|-----------------------------------------|---------------|--------------|
| Design / build their own?               |               | ✓            |
| 99% in stock now?                       |               | ✓            |
| Next day, on-time delivery?             |               | ✓            |
| Over a hundred items to choose from?    |               | ✓            |
| Portable antenna kits?                  |               | ✓            |
| Equipment still working after 40 years? |               | ✓            |
| Over 80 years of experience?            |               | ✓            |
| Personal technical support?             |               | ✓            |
| Personal Customer Service?              |               | ✓            |
| Global support network?                 |               | ✓            |

A.H. Systems does *all* of this, *all* of the time because we are the EMI test Antenna Specialists. We do not build “Boxes”. We do not build “Systems”. We do design and build the highest quality, most accurate EMI test antennas (20 Hz - 40 GHz).

It may be more convenient to buy everything from one supplier, but remember “Your test system is only as good as the antenna you put in front of it!”



**Log Periodics**  
80 MHz - 7 GHz  
13 Models

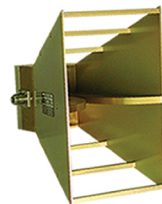

**DRG Horns**  
170 MHz - 40 GHz  
6 Models



**All in one small package**  
20 Hz - 40 GHz



**Biconicals**  
20 MHz - 18 GHz  
7 Models

## The Antenna Specialists



**Innovation**

**Quality**

**Performance**

Phone: (818)998-0223 ♦ Fax (818)998-6892  
<http://www.AHSystems.com>

**A.H. Systems**





# SUMMARY OF MILITARY AND AEROSPACE EMC TESTS

---

**Ghery Pettit**

Pettit EMC Consulting

Ghery@PettitEMCConsulting.com

## **Introduction**

Military and aerospace EMC tests cover a wide range of products. While the standards, including limits and test methods may differ, all EMC test standards have a few things in common. The most basic are the limits for emissions and the types and levels of susceptibility testing.

Emissions tests (and their associated limits) are put in place for military and aerospace equipment primarily to protect other systems from interference. These other systems may or may not include radio equipment. Examples abound showing the effect of inadequate EMC design. The Interference Technology 2016 Military EMC Guide (Reference 1) provides 3 such examples on page 11.



SUMMARY OF MILITARY AND AEROSPACE EMC TESTS

While many military and aerospace EMC issues may be addressed by operational changes, testing is still required to find weaknesses.

Military and aerospace EMC testing is performed at the system and subsystem levels. MIL-STD-464C provides requirements at the system or platform level. The latest version, MIL-STD-461G, provides requirements at the equipment or subsystem level. *Reference 1* provides details on both of the standards, but this article will highlight some key tests, particularly as they relate to MIL-STD-461G.

| Ratio | Description                                                                    |
|-------|--------------------------------------------------------------------------------|
| CE101 | Conducted Emissions, Audio Frequency Currents, Power Leads                     |
| CE102 | Conducted Emissions, Radio Frequency Potentials, Power Leads                   |
| CE106 | Conducted Emissions, Antenna Port                                              |
| CS101 | Conducted Susceptibility, Power Leads                                          |
| CS103 | Conducted Susceptibility, Antenna Port, Intermodulation                        |
| CS104 | Conducted Susceptibility, Antenna Port, Rejection of Undesired Signals         |
| CS105 | Conducted Susceptibility, Antenna Port, Cross-Modulation                       |
| CS109 | Conducted Susceptibility, Structure Current                                    |
| CS114 | Conducted Susceptibility, Bulk Cable Injection                                 |
| CS115 | Conducted Susceptibility, Bulk Cable Injection, Impulse Excitation             |
| CS116 | Conducted Susceptibility, Damped Sinusoidal Transients, Cables and Power Leads |
| CS117 | Conducted Susceptibility, Lightning Induced Transients, Cables and Power Leads |
| CS118 | Conducted Susceptibility, Personnel Borne Electrostatic Discharge              |
| RE101 | Radiated Emissions, Magnetic Field                                             |
| RE102 | Radiated Emissions, Electric Field                                             |
| RE103 | Radiated Emissions, Antenna Spurious and Harmonic Outputs                      |
| RS101 | Radiated Susceptibility, Magnetic Field                                        |
| RS103 | Radiated Susceptibility, Electric Field                                        |
| RS105 | Radiated Susceptibility, Transient Electromagnetic Field                       |

Table 1: MIL-STD-461G Emission and susceptibility requirements

MIL-STD-461G divides test requirements into 4 basic types. Conducted Emissions (CE), Conducted Susceptibility (CS), Radiated Emissions (RE) and Radiated Susceptibility (RS). There are a number of tests in each category and the following table, taken from MIL-STD-461G *Table IV*, shows these test methods.

A brief description of each these tests will be provided below. These are summarized from a more detailed introduction to MIL-STD-461G, which is found in the *References 1, 2, and 3*. Keep in mind that a complete copy of MIL-STD-461G is 280 pages, so any information here is brief and the standard must be read and understood. A copy of MIL-STD-461G may be obtained free. See *Reference 4*.

CE101 Conducted Emissions, Audio Frequency Currents, Power Leads. CE101 is applicable from 30 Hz to 10 kHz for leads that obtain power from sources that are not part of the EUT. There is no requirement on output leads from power sources. Emission levels are determined by measuring the current present on each power lead. There is different intent behind this test based on the usage of equipment and the military service involved. The specific limits are based on application, input voltage, frequency, power and current.

CE102 Conducted Emissions, Radio Frequency Potentials, Power Leads. CE102 is applicable from 10 kHz to 10 MHz for leads that obtain power from sources that are not part of the EUT. There is no requirement on output leads from power sources. The lower frequency portion is to ensure EUT does not corrupt the power quality (allowable voltage distortion) on platform power buses. Voltage distortion is the basis for power quality so CE102 limit is in terms of voltage. The emission levels are determined by measuring voltage present at the output port of the LISN. Unlike CE101, CE102 limits are based on voltage. The basic limit is relaxed for increasing source voltages, but independent of current. Failure to meet the CE102 limits can often be traced to switching regulators and their harmonics.

CE106 Conducted Emissions, Antenna Port. CE106 is applicable from as low as 10 kHz to as high as 40 GHz (depending on the operating frequency) for antenna terminals of transmitters, receivers, and amplifiers and is designed to protect receivers on and off the platform from being degraded by antenna radiation from the EUT. CE106 is not applicable for permanently mounted antennas.

CS101 Conducted Susceptibility, Power Leads. CS101 is applicable from 30 Hz to 150 kHz for equipment and subsystem AC and DC power input leads. For DC powered equipment, CS101 is required over the entire 30 Hz to 150 kHz range. For AC powered equipment, CS101 is only required from the second harmonic of the equipment power frequency (120 Hz for 60 Hz equipment) to



150 kHz. In general, CS101 is not required for AC powered equipment when the current draw is greater than 30 amps per phase. The exception is when the equipment operates at 150 kHz or less and has an operating sensitivity of 1  $\mu\text{V}$  or better. The intent is to ensure that performance is not degraded from ripple voltages on power source waveforms.

CS103, CS104 and CS105 Conducted Susceptibility, Antenna Port, Intermodulation, Rejection of Undesired Signals and Cross-Modulation. This series of receiver front-end tests include test methods for Intermodulation (CS103), Rejection of Undesired Signals (CS104) and Cross Modulation (CS105). They were designed for traditional tunable super-heterodyne type radio receivers. Due to the wide diversity of radio frequency subsystem designs being developed, the applicability of this type of requirement and appropriate limits need to be determined for each procurement. Also, requirements need to be specified that are consistent with the signal processing characteristics of the subsystem and the particular test procedures to be used to verify the requirement.

CS109 Conducted Susceptibility, Structure Current. CS109 is a highly specialized test applicable from 60 Hz to 100 kHz for very sensitive Navy shipboard equipment (1  $\mu\text{V}$  or better) such as tuned receivers operating over the frequency range of the test. Handheld equipment is exempt from CS109. The intent is to ensure that equipment does not respond to magnetic fields caused by currents flowing in platform structure. The limit is derived from operational problems due to current conducted on equipment cabinets and laboratory measurements of response characteristics of selected receivers.

CS114 Conducted Susceptibility, Bulk Cable Injection. CS114 is applicable from 10 kHz to 200 MHz for all electrical cables interfacing with the EUT enclosures.

CS115 Conducted Susceptibility, Bulk Cable Injection, Impulse Excitation. CS115 is applicable to all electrical cables interfacing with EUT enclosures. The primary concern is to protect equipment from fast rise and fall time transients that may be present due to platform switching operations and external transient environments such as lightning and electromagnetic pulse.

CS116 Conducted Susceptibility, Damped Sinusoidal Transients, Cables and Power Leads. CS116 is applicable to electrical cables interfacing with each EUT enclosure and also on each power lead. The concept is to simulate electrical current and voltage waveforms occurring in platforms from excitation of natural resonances with a control damped sine waveform.

CS117 Conducted Susceptibility, Lightning Induced Transients, Cables and Power Leads. CS117 is one of two new test methods added to MIL-STD-461G. CS117 is

applicable to safety-critical equipment interfacing cables and also on each power lead. Applicability for surface ship equipment is limited to equipment located above deck or which includes interconnecting cables, which are routed above deck. The concept is to address the equipment-level indirect effects of lightning as outlined in MIL-STD-464 and it is not intended to address direct effects or nearby lightning strikes.

CS118 Conducted Susceptibility, Personnel Borne Electrostatic Discharge. CS118 is applicable to electrical, electronic, and electromechanical subsystems and equipment that have a man-machine interface. It should be noted that CS118 is not applicable to ordnance items. The concept is to simulate ESD caused by human contact and test points are chosen based on most likely human contact locations. Multiple test locations are based on points and surfaces which are easily accessible to operators during normal operations. Typical test points would be keyboard areas, switches, knobs, indicators, and connector shells as well as on each surface of the EUT.

RE101 Radiated Emissions, Magnetic Field. RE101 is applicable from 30 Hz to 100 kHz and is used to identify radiated emissions from equipment and subsystem enclosures, including electrical cable interfaces. RE101 is a specialized requirement, intended to control magnetic fields for applications where equipment is present in the installation, which is potentially sensitive to magnetic induction at lower frequencies.

RE102 Radiated Emissions, Electric Field. RE102 is applicable from 10 kHz to 18 GHz and is used to identify radiated emissions from the EUT and associated cables. It is intended to protect sensitive receivers from interference coupled through the antennas associated with the receiver.

RE103 Radiated Emissions, Antenna Spurious and Harmonic Outputs. RE103 may be used as an alternative for CE106 when testing transmitters with their intended antennas. CE106 should be used whenever possible. However, for systems using active antenna or when the antenna is not removable or the transmit power is too high, RE103 should be invoked. RE103 is applicable and essentially identical to CE106 for transmitters in the transmit mode in terms of frequency ranges and amplitude limits. The frequency range of test is based on the EUT operating frequency.

RS101 Radiated Susceptibility, Magnetic Field RS101 is a specialized test applicable from 30 Hz to 100 kHz for Army and Navy ground equipment having a minesweeping or mine detection capability, for Navy ships and submarines, that have an operating frequency of 100 kHz or less and an operating sensitivity of 1  $\mu\text{V}$  or better (such as 0.5  $\mu\text{V}$ ), for Navy aircraft equipment installed on ASW capable aircraft, and external equipment on aircraft that are capable of being launched by electromagnetic launch

systems. The requirement is not applicable for electromagnetic coupling via antennas. RS101 is intended to ensure that performance of equipment susceptible to low frequency magnetic fields is not degraded.

RS103 Radiated Susceptibility, Electric Field. RS103 is applicable from 2 MHz to 18 GHz in general, but the upper frequency can be as high as 40 GHz if specified by the procuring agency. It is applicable to both the EUT enclosures and EUT associated cabling. The primary concern is to ensure that equipment will operate without degradation in the presence of electromagnetic fields generated by antenna transmissions both onboard and external to the platform. The limits are platform dependent and are based on levels expected to be encountered during the service life of the equipment. It should be noted that RS103 may not necessarily be the worst case environment to which the equipment may be exposed.

RS105 Radiated Susceptibility, Transient Electromagnetic Field. RS105 is intended to demonstrate the ability of the EUT to withstand the fast rise time, free-field transient environment of EMP. RS105 applies for equipment enclosures which are directly exposed to the incident field outside of the platform structure or for equipment inside poorly shielded or unshielded platforms and the electrical interface cabling should be protected in shielded conduit.

Not all tests are required for each type of device or intended use environment. MIL-STD-461G provides a matrix in Table V showing how these tests are used based on the intended use of the device.

Again, the reader is referred to *References 1* through *3* for more details, or to MIL-STD-461G for the details of the standard (*Reference 4*). This guide also provides a list of standards that apply to various military equipment.

A popular and common aerospace EMC requirement required by the FAA for commercial aircraft is RTCA/DO-160, Environmental Conditions and Test Procedures for Airborne Equipment. The latest version is RTCA/DO-160 G, published on December 8, 2010, with Change 1 published on December 16, 2015. DO-160 covers far more than just EMC issues, but the EMC subjects covered include input power conducted emissions and susceptibility, transients, drop-outs and hold-up; voltage spikes to determine whether equipment can withstand the effects of voltage spikes arriving at the equipment on its power leads, either AC or DC; audio frequency conducted susceptibility to determine whether the equipment will accept frequency components of a magnitude normally expected when the equipment is installed in the A/C; induced signal susceptibility to determine whether the equipment interconnect circuit configuration will accept a level of induced voltages caused by the installation environment; RF emissions and susceptibility; lightning susceptibility; and electrostatic discharge susceptibility.

This document can be purchased from RTCA on their website (*Reference 5*). A manufacturer producing products subject to the requirements in RTCA/DO-160 should obtain a copy and ensure they have a complete understanding of the content of the document and that any laboratory testing to it is properly accredited.

Examples of differences in test equipment between commercial and military standards.

There are differences in test equipment used compared with commercial EMC tests. Some examples are provided below.

Where 50 µH LISNs are universally required for commercial EMC tests, there are specific cases for CE01 and CE02 tests where a 5 µH LISN is called out. Limits for CE101 tests are provided in dBµA. LISNs are only used for line impedance stabilization. The measurements are taken with current probes. Limits for CE102, on the other hand, are given in dBµV and measurements are taken in much the same way as for commercial standards with the receiver connected to the RF output port of one of the LISNs and the other RF output port(s) terminated in 50 Ohms. It should be noted that MIL-STD-461G calls out a 20 dB pad on the output of the LISN to protect the receiver from transients. This is not a requirement in the commercial standards, but is worth considering when setting up a laboratory for commercial testing, as well.

Military EMC standards, such as MIL-STD-461G will require the use of different antennas for radiated emis-

| Equipment and Subsystems Installed In, On, or Launched From the Following Platforms or Installations | Type of Product/Service |       |       |       |       |       |       |       |       |       |       |       |       |       |       |       |       |       |       |
|------------------------------------------------------------------------------------------------------|-------------------------|-------|-------|-------|-------|-------|-------|-------|-------|-------|-------|-------|-------|-------|-------|-------|-------|-------|-------|
|                                                                                                      | CE101                   | CE102 | CE106 | CS101 | CS103 | CS104 | CS105 | CS109 | CS114 | CS115 | CS116 | CS117 | CS118 | RE101 | RE102 | RE103 | RS101 | RS103 | RS105 |
| Surface Ships                                                                                        | A                       | A     | L     | A     | S     | L     | S     | L     | A     | S     | A     | L     | S     | A     | A     | L     | L     | A     | L     |
| Submarines                                                                                           | A                       | A     | L     | A     | S     | L     | S     | L     | A     | S     | L     | S     | S     | A     | A     | L     | L     | A     | L     |
| Aircraft, Army, Including Flight Line                                                                | A                       | A     | L     | A     | S     | S     | S     |       | A     | A     | A     | L     | A     | A     | A     | L     | A     | A     | L     |
| Aircraft, Navy                                                                                       | L                       | A     | L     | A     | S     | S     | S     |       | A     | A     | A     | L     | A     | L     | A     | L     | L     | A     | L     |
| Aircraft, Air Force                                                                                  |                         | A     | L     | A     | S     | S     | S     |       | A     | A     | A     | L     | A     |       | A     | L     |       | A     |       |
| Space Systems, Including Launch Vehicles                                                             |                         | A     | L     | A     | S     | S     | S     |       | A     | A     | A     | L     | A     |       | A     | L     |       | A     |       |
| Ground Army                                                                                          |                         | A     | L     | A     | S     | S     | S     |       | A     | A     | A     | S     | A     |       | A     | L     | L     | A     |       |
| Ground Navy                                                                                          |                         | A     | L     | A     | S     | S     | S     |       | A     | A     | A     | S     | A     |       | A     | L     | L     | A     | L     |
| Ground, Air Force                                                                                    |                         | A     | L     | A     | S     | S     | S     |       | A     | A     | A     |       | A     |       | A     | L     |       | A     |       |

Legend:  
A: Applicable (in green)  
L: Limited as specified in the individual sections of this standard. (in yellow)  
S: Procuring activity must specify in procurement documentation. (in red)

Table 2: MIL-STD-461G Requirement matrix



sions testing. Commercial equipment standards, such as CISPR 32 and ANSI C63.4, require the use of linearly polarized antennas and do not contain requirements for magnetic field testing.

MIL-STD-461G, RE101, requires the use of a 13.3 cm loop sensor, not required in the commercial standards. A receiver capable of tuning from 30 Hz to 100 kHz is needed.

MIL-STD-461G, RE102, requires testing of radiated emissions to as low as 10 kHz. From 10 kHz to 30 MHz a 104 cm (41 inch) rod antenna is used. This frequency range is not covered in CISPR 32 or the FCC Rules for radiated emissions. Thus, the antenna and receiver requirements are different. From 30 MHz to 200 MHz a biconical antenna is used, also commonly used in commercial testing. From 200 MHz to 1 GHz a double ridge horn antenna is called out in 461G. This is different than the tuned dipole or log periodic dipole array antennas used for commercial testing.

The test procedures are also different for radiated emissions testing, requiring different laboratory set-ups and test facility types. No turntable is needed for MIL-STD-461G, nor is an antenna mast capable of moving the antenna over a range of heights.

MIL-STD-461G, RS103, can require significantly higher field intensities for radiated susceptibility testing. Where

CISPR 35 requires 3 V/m from 80 MHz to 1 GHz and at a few discrete frequencies up to 5 GHz (with the option of testing a few discrete frequencies at up to 30 V/m), MIL-STD-461G requires testing from 20 V/m to as high as 200 V/m over the range of 2 MHz to 40 GHz for certain equipment. Additional test equipment (signal generators, amplifiers, antennas, etc.) is required over that needed for commercial testing.

Each test in MIL-STD-461G requires its own unique test equipment. Some may be useable for commercial testing, others may not. If testing to MIL-STD-461G, ensure that the equipment is proper for the tests being performed. A detailed understanding of the requirements in MIL-STD-461G is required to ensure that the proper equipment is being used and the laboratory is following the appropriate processes.

---

### References

1. 2016 Military EMC Guide, Interference Technology
2. Ken Javor, MIL-STD-461G: The "Compleat" Review, Interference Technology, April 2016
3. Ken Javor, Why Is There AIR (in MIL-STD-461G)?, Interference Technology, April 2016
4. MIL-STD-461G, December 2015, Defense Acquisition System
5. RTCA/DO-160G, RTCA, December 2010.





An A2LA Accredited test lab for all of your international RF and EMC product certification and testing needs.

## Compliance and Testing Services

MiCOM Labs has always aimed to break free from outdated methodologies, delivering cutting edge testing and certification services to our clients. With our regulatory expertise and state-of-the-art facility, we continue to push the envelope with intuitive automated compliance solutions. This allows our clients to stay compliant to global regulatory standards and remain competitive in the marketplace.

### RF TESTING

- WLAN/RLAN
- Bluetooth/BLE
- RFID
- Zigbee
- Microwave Radios
- Cellular
- Medical, Industrial and Commercial Electronics
- Airborne/Maritime Devices
- IOT Technologies

### EMC TESTING

- Radiated and Conducted Emissions
- Radiated and Conducted Immunity
- Electrostatic Discharge, Harmonics, and Voltage Dips/Fluctuations
- Flicker, Transients and Surge

### SAFETY TESTING

- IEC 62368

**Contact us today to find your testing and certification solution.**

p: 1.925.462.0304 | e: [sales@micomlabs.com](mailto:sales@micomlabs.com) | w: [micomlabs.com](http://micomlabs.com)

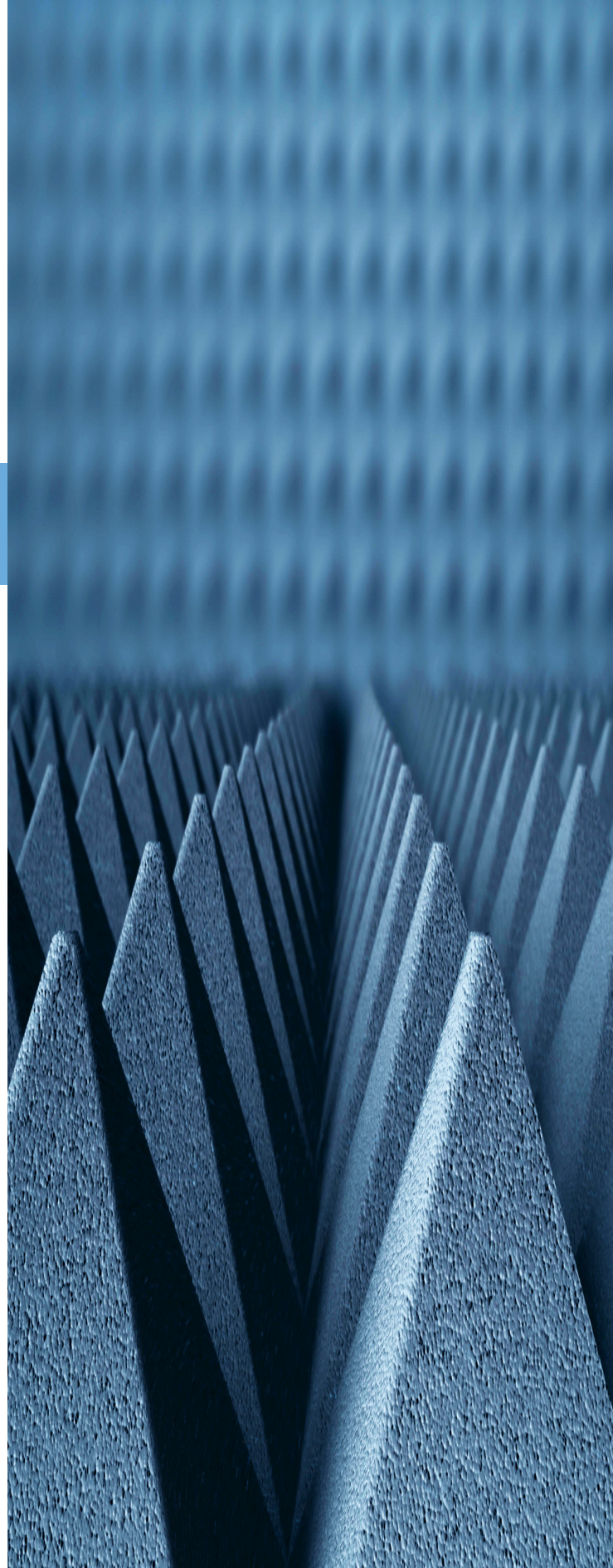



# EMI TROUBLESHOOTING WITH REAL-TIME SPECTRUM ANALYZERS

**Kenneth Wyatt**  
Wyatt Technical Services LLC  
ken@emc-seminars.com

*The latest tool for serious EMI troubleshooting or debugging has become the real-time (RT) spectrum analyzer. Because manufacturing costs have been decreasing, some RT analyzers are becoming more affordable than ever. In this article, I'll show you the advantages in using RT analysis for observing and troubleshooting unusual EMI.*

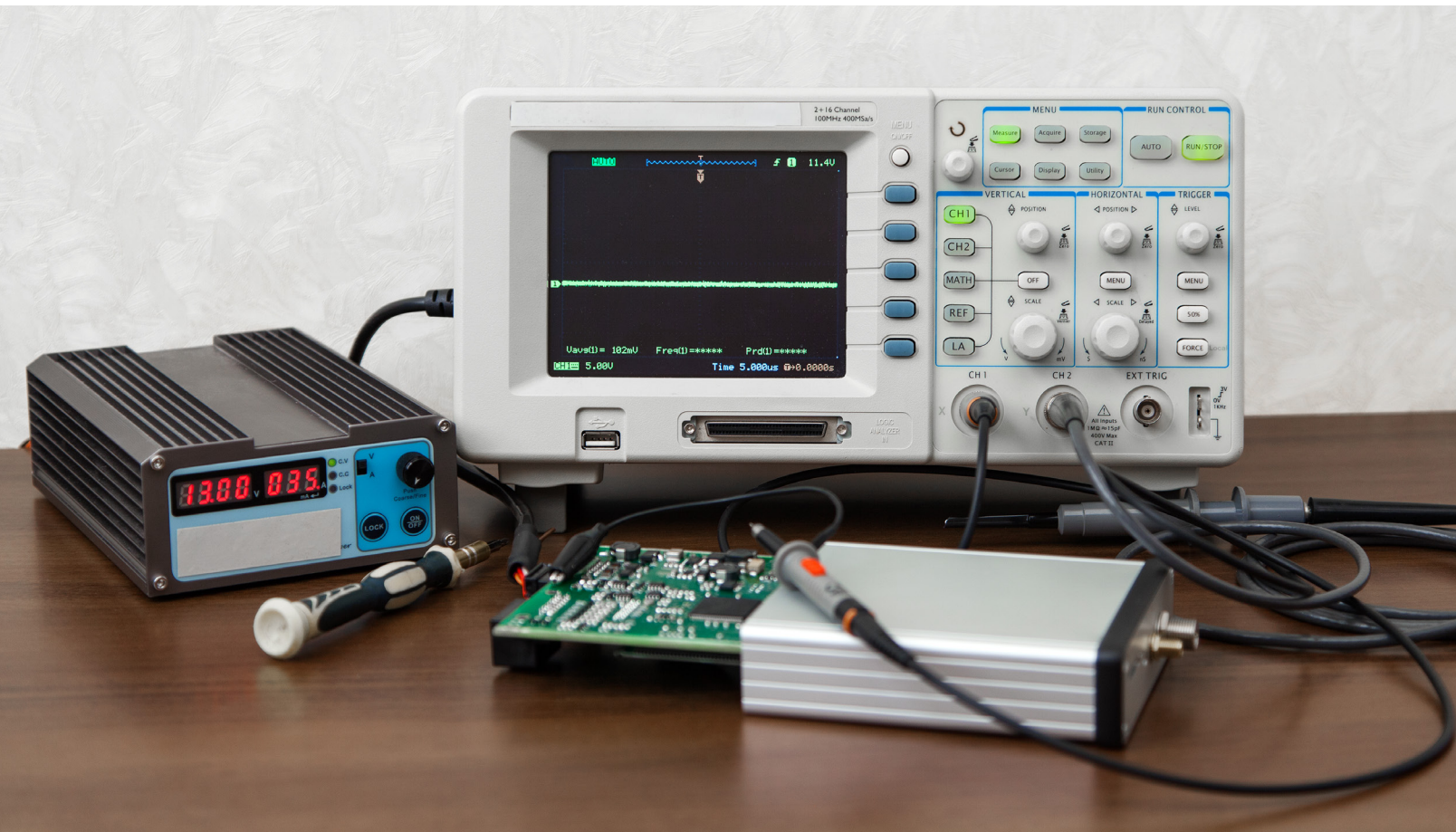

## EMI TROUBLESHOOTING WITH REAL-TIME SPECTRUM ANALYZERS

### Introduction

First, let's review the differences between the conventional swept and real-time spectrum analyzers.

**Swept-Tuned Analyzer** – The swept analyzer uses a tunable local oscillator in a standard superhetrodyne circuit. It can sweep over a specified frequency range and using a user-selected resolution (or “receiver”) bandwidth. RF signals introduced to the input port are mixed with the local oscillator and the specified frequency span is displayed as RF power versus frequency. The only time data is captured is during the sweep time. After the frequency sweep, the captured data is processed and displayed. There is usually significant delay (or “dead” time) between sweeps, so it's quite possible for the analyzer to miss capturing intermittent or fast-moving signals.

**Real-Time Analyzer** – A real-time analyzer uses a stationary LO, looks at narrow windows of bandwidth (real-time bandwidth), and digitizes the incoming spectrum. This digitized spectrum is stored in a time record buffer and held for processing by the FFT algorithm. Ideally, once digitized, FPGAs process FFTs at a rate equal, or faster, than the collection rate. However, this collection rate depends on the span and resolution bandwidth. The major difference between the swept-tuned analyzer and real-time analyzer is the sheer number-crunching ability of the real-time calculation, as well as a fast graphics processor, which allows for a data-dense display of various frequency-versus-time presentations and digital demodulation.

The advantages of a RT analyzer is the ability to capture RF pulses as short as 20 us, digital modulations, and other pulsing or fast changing signals. In addition, they can capture and process data much faster than swept analyzers – there's no need to wait seconds or minutes to capture a spectrum. This allows very fast troubleshooting, since you can see the result of fixes immediately.

Finally, the RT analyzers have an addition feature called a spectrogram (or “waterfall”) display, where signals are shown versus time. This is a great feature allowing you to determine the timing of intermittent EMI.

I'll be using the Tektronix RSA306B (*Reference 1*) real-time USB-controlled spectrum analyzer with Tekbox Digital Solutions (*Reference 2*) near field probes for this article, but there are many other choices available.

*Figure 1* shows a typical advantage of the RT display over that of the swept display. Here, we see some broadband motor noise completely masking several narrow band harmonics. The swept analyzer has trouble capturing the motor noise, but we can see occasional captures indicating there was “something” there. Max Hold mode and

waiting a while will help fill in the swept display, but then you'd miss seeing the narrow band emissions.

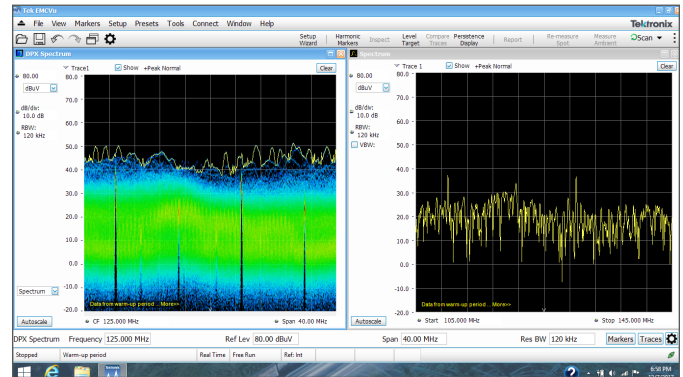

**Figure 1** – An example where the broadband emissions from a motor controller completely mask a series of narrow band harmonics. You can see on the right that the standard swept analyzer has trouble capturing this broadband noise.

Most RT analyzers will also have optional EMI software that will help collect data or even perform pre-compliance testing for radiated and conducted emissions. For example, Tektronix offers their SignalVu-PC software with the RSA306B, but also recently announced their EMI troubleshooting and pre-compliance software for the RSA-series, called “EMCVu”. EMCVu includes some impressive EMI troubleshooting and pre-compliance test features and can switch from one mode to the other quickly. It comes with pre-defined transducer factors (antenna and cable loss tables), CISPR and FCC limit lines, and easy report generation. In pre-compliance mode, it can scan the entire frequency range in a few seconds, numbering all the harmonics above the limit and within a certain margin to the limit. These captured harmonic signals can then be examined more closely and then switched over to troubleshooting mode to try various fixes.

Either SignalVu-PC or EMCVu will work fine for basic troubleshooting or debugging emission issues and I've actually used both for this article. If you also want pre-compliance test capability in-house (a wise decision) or more advanced troubleshooting tools, then you'll want to invest in EMCVu.

### Three-Step Process for EMI Troubleshooting

I've developed a three-step process for EMI troubleshooting, which I'll briefly explain below. We'll use Tektronix' SignalVu-PC or EMCVu as an example, but several other companies sell similar compliance software. You'll want to download the free “2017 EMI Pre-Compliance Test Guide” from Interference Technology for more details on this troubleshooting process (*Reference 3*).

**Step 1** – Use near field probes (either H- or E-field) to identify energy sources and characteristic emission profiles on the PC board and internal cables. Energy sources generally include clock oscillators, processors, RAM, D/A or A/D converters, DC-DC converters, and other sources,



which produce fast-edged digital signals. If the product includes a shielded enclosure, probe for leaky seams of other apertures. Record the emission profile of each energy source.

**Step 2** – Use a current probe to measure high frequency cable currents. Remember, cables are the most likely structure to radiate RF energy. Move the probe back and forth along the cable to maximize the highest currents. Record the emission profile of each cable.

**Step 3** – Use a nearby antenna (I use a 1m test distance) to determine which of the harmonic content actually radiates. Catalog these harmonics and compare to the internal and cable measurements. This will help you determine the most likely energy sources that are coupling to cables or seams and radiating.

### Analyze the Data

Remember that not all near field signals will couple to “antenna-like” structures and radiate. Use a harmonic analyzer tool (see *Reference 4*) to help identify harmonics belong to specific energy sources. Note that in many cases, two, or more, sources will generate the some (or all) the same harmonics. For example, a 25 MHz clock and 100 MHz clock can both produce harmonics of 100, 200, 300 MHz, etc. Oftentimes, you’ll need to fix more than one source to eliminate a single harmonic. EMCVu includes some powerful data capture and documentation features that will help speed up the data collection process from steps 1 through 3.

After the harmonics are analyzed and you have identified the most likely sources, the next step is to determine the coupling path from source and out the product. Usually, it’s the I/O or power cables that are the actual radiating structure. Sometimes, its leaky seams or apertures (display or keyboard, for example).

There are four possible coupling paths; conducted, radiated, capacitive, and inductive. The latter two (capacitive and inductive) are so-called; “near field” coupling and small changes in distance between source and victim should create large effects in radiated energy. For example, a ribbon cable routed too close to a power supply heat sink (capacitive coupling or  $dV/dt$ ) and causing radiated emissions can be resolved merely by moving the ribbon cable further away from the heat sink. The inductive coupling ( $di/dt$ ) between a source and victim cable can also be reduced by rerouting. Both these internal coupling mechanisms (or similar PC board design issues) can lead to conducted (out power cables) or radiated (I/O or power cables acting as antennas, or enclosure seams/apertures) emissions.

In many cases, its simply poor cable shield bonding to shielded enclosures or lack of common-mode filtering at I/O or power ports that lead to radiated emissions.

### How Can RT Analyzers Help Troubleshoot EMI?

So, let’s turn our attention back to probing the PC board and cables. How often have you probed, troubleshot, and fixed a product only to have it fail at the compliance test facility? Many of today’s products, especially mobile products, include on board DC-DC converters that produce a very broadband EMI spectrum out past 1 GHz that can impact the operation of cellular or GPS wireless receivers. In addition, digital processors can change emission characteristics with time or operating mode. Add wireless features and you have a myriad of potential energy sources that can change emission characteristics with time.

I’d like to demonstrate a some examples where swept analyzers might very well miss a bursting increase in emissions or fail to capture broadband EMI that is greater in amplitude than the usual narrow band harmonics we’re all used to.

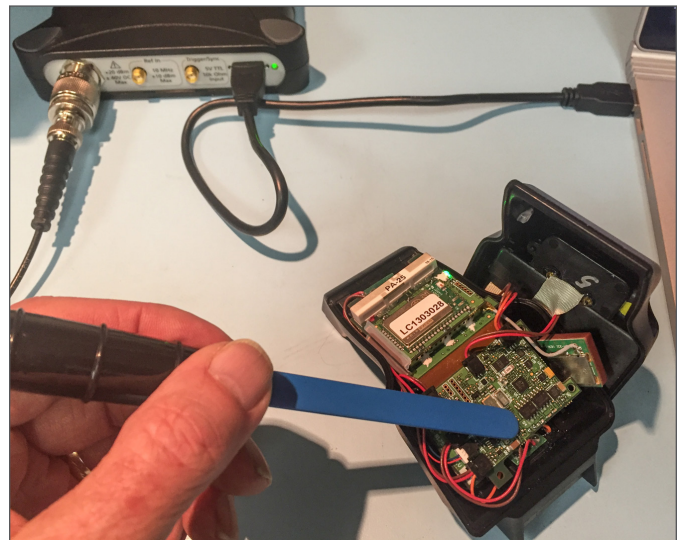

Figure 2 - Using a near field (H-field) probe on an on-board DC-DC converter in a small mobile device. I’m using the Tektronix RSA306B USB-controlled RT spectrum analyzer and Tekbox near field probe.

### Example 1 – Pulsating Harmonic EMI

Most of the time, you’ll find narrow band harmonics are relatively stable in amplitude. However, there are times when the amplitude can change, due to gated digital signals or different operating modes. If the harmonic peaks upward at the wrong time, it can lead to compliance failures.

Swept analyzers can easily miss these infrequent amplitude peaks. Placing the swept analyzer in “Max Hold” mode can help, but it could take several minutes to capture the peak of the emission. Even so, peaks can be missed, due to dead time in between scans.

RT analyzers, on the other hand are adept at capturing fast changing signals. Here’s an example where I was measuring the narrow band low frequency emissions from an on-board DC-DC converter on a small mobile device (*Figure 2*).

In *Figure 3*, we're looking from 9 kHz to 10 MHz and we see the swept measurement is even having a hard time capturing the regular peak emissions, while the RT measurement captures the peaks easily and even detects an occasional six dB pulsing increase in amplitude (as shown in the blue persistence display). That infrequent pulsing amplitude increase could easily cause a compliance failure should it couple out through conduction or radiation.

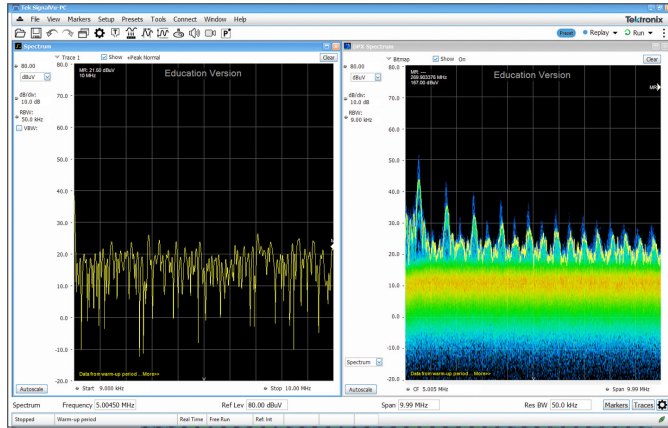

Figure 3 – Measuring the emissions from an on-board DC-DC converter and comparing swept (left) and real-time (right). Note the 6 dB peaks in the blue persistence display.

**Example 2 – Identification of Emissions Due to Different Operating Modes**

In this example, we're measuring that same DC-DC converter (*Figure 1*), but looking from 105 to 145 MHz, a frequent area of compliance failures due to radiated emissions. The surprising result was the three very different spectral responses, due to different operating modes of the mobile device. In some cases, the emission was about 25 dB higher than the swept measurement could capture. Now, would you be willing to take the risk that the swept measurement at the compliance test facility would either miss or manage to capture this should it couple out and radiate?

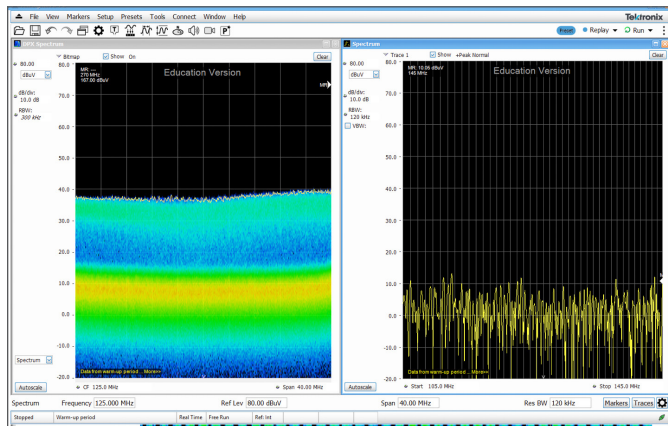

Figure 4 – Broadband emissions from the DC-DC converter looking from 105 to 145 MHz. The swept measurement on the right was unable to successfully capture this, except for an occasional burst. Max Hold mode would have helped, but would have taken at least a minute to “fill in” the display. But once the display was filled in, you may not have been able to see the following two very different modes in Figures 5 and 6

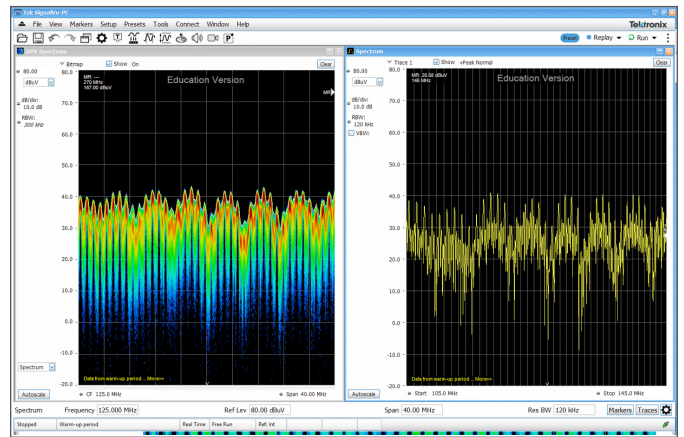

Figure 5 – Without moving the probe, we see “mode 2” from the DC-DC converter, which briefly appeared.

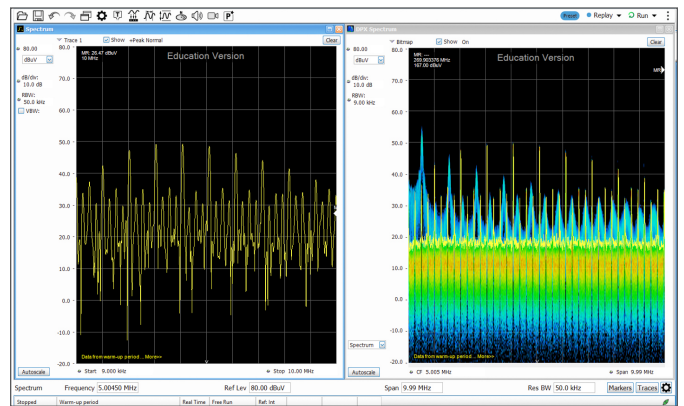

Figure 6 – Again, without moving the probe, we see “mode 3” with much increased narrow band emissions measuring about 10 dB higher than modes 1 and 2. This brief occurrence could have been the mode that would have resulted in a compliance failure, should the emission get coupled out and radiate.

*Figures 4, 5, and 6* show the three different spectral modes. Notice that the swept measurement managed to capture only two of the three spectrums. The near field probe was not moved during this sequence. Each mode was instantly viewable as the state changed from one mode to another.

**Example 3 – Detection of Spurious Oscillation**

In this example, we don't necessarily need the RT capture, but it does yield some interesting visual clues once we activate the spectrogram (waterfall) display feature.

The board being measured is a demo board from Picotest Technologies (*Figure 7*) and I discovered one of the op-amps produced an interesting bimodal series of spurious oscillations at about 150 MHz intervals. I was able to induce this oscillation by “switching out” the output capacitance.

It turns out that when the op-amp was unloaded capacitively, it produced a very interesting oscillation at near its open loop bandwidth (*Figure 8*). Examining the RT measurement on the right, we can see there's a distinct



bimodal (two-frequency) display, along with some cool sideband emissions. The swept display on the left can only capture one of these two frequencies at a time, at best, as the oscillation is switching from one frequency to the other.

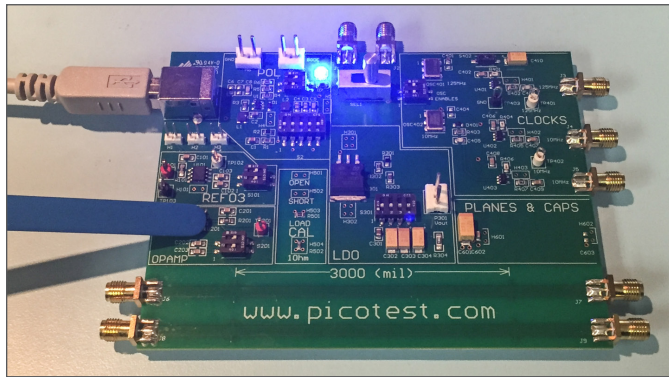

Figure 7 - Measuring an op-amp on the Picotest Technologies demo board.

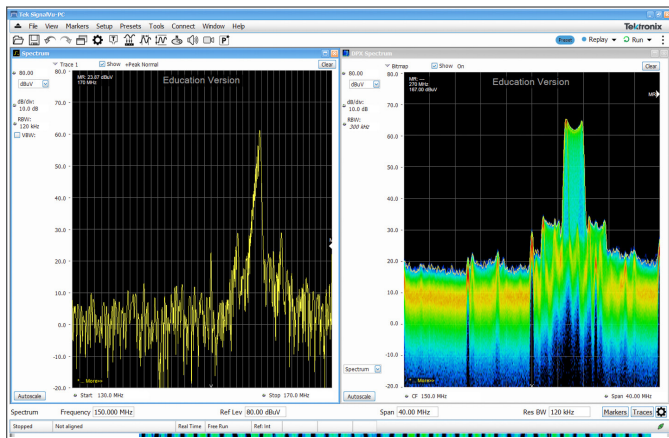

Figure 8 - Measurement of an interesting spurious oscillation of an op-amp. Note that the swept measurement on the left can only capture one of the bimodal states at a time, while the RT capture on the right is very detailed.

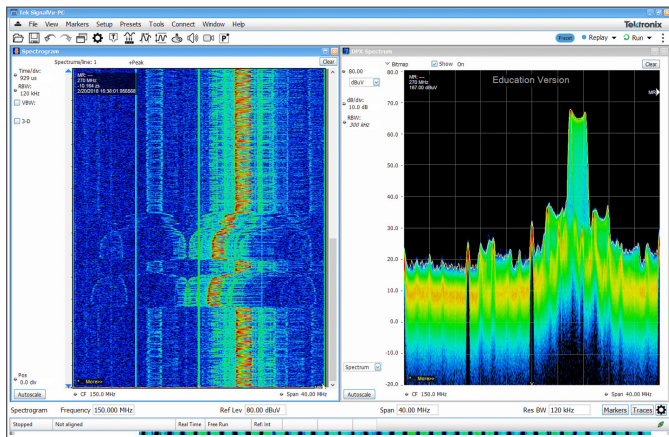

Figure 9 - Replacing the swept display with a spectrogram (frequency versus time), we can observe some interesting details (see text).

But let's analyze the "bi-modal-ness" a little closer by replacing the swept display with a spectrogram of frequency versus time.

One thing I noticed (and this is very common for spurious oscillations) is that placing my finger on the area of the op-amp changed the parasitic characteristics enough to shift the oscillation frequency quite a bit downward. You can see that shift in the spectrogram display in Figure 9 as I touched my finger to the area twice.

The other thing to note is that you can now easily observe the switching between one oscillation frequency and the other in the "zig zag" pattern in the spectrogram. Note that the oscillation spends more time at the lower frequency, rather than the upper frequency. This is also indicated by the slightly higher amplitude of the left side of the double peak.

**Conclusion**

As technology continues to advance, we EMC engineers and product designers need to upgrade our usual analysis and pre-compliance test tools to stay one step ahead and be able to better capture and display the more unusual emissions expected. Real-time spectrum analyzers have already proven to be invaluable for EMI debug and troubleshooting. Advanced spectral analysis will be especially important as mobile devices continue to shrink and more products incorporate wireless and other advanced digital modes.

**Author Bio**

Kenneth Wyatt is president and principal consultant of Wyatt Technical Services LLC, as well as the senior technical editor for Interference Technology. He has worked in the field of EMC engineering for 30 years. His specialty is EMI troubleshooting and pre-compliance testing and is a co-author of the popular EMC Pocket Guide and RFI Radio Frequency Interference Pocket Guide. He also coauthored the book with Patrick André, EMI Troubleshooting Cookbook for Product Designers, with forward by Henry Ott. He is widely published and authored The EMC Blog hosted by EDN.com for nearly three years. Kenneth is a senior member of the IEEE and a long time member of the EMC Society.

► He may be contacted at:  
[ken@emc-seminars.com](mailto:ken@emc-seminars.com) or  
[kwyatt@interferencetechnology.com](mailto:kwyatt@interferencetechnology.com)

► Check out his web site for more technical information, training schedules, and links:  
[www.emc-seminars.com](http://www.emc-seminars.com)

# Register Now! @ EDICONUSA.COM

Register by August 31 to take advantage of early bird discounts.

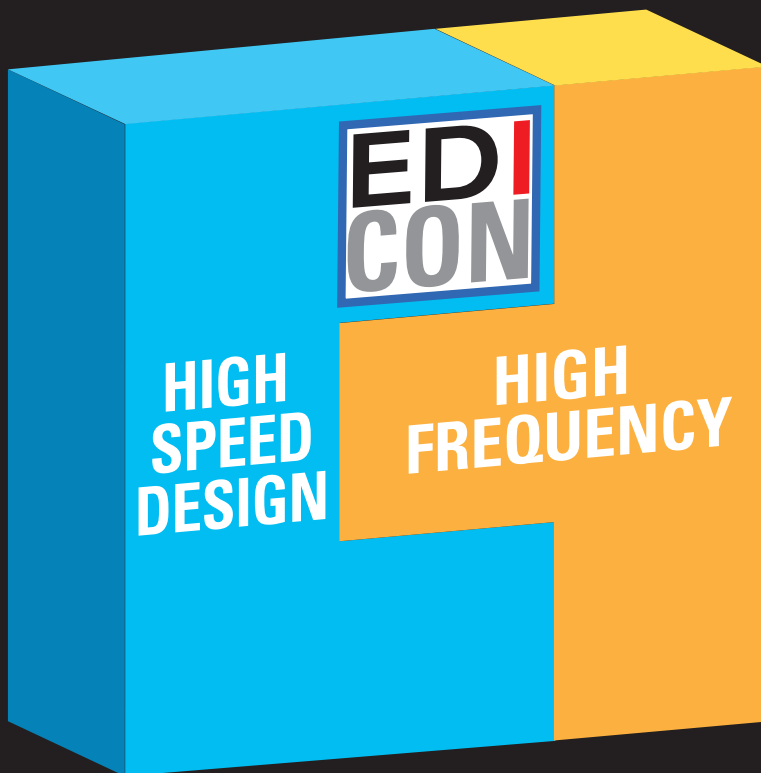

## The Only Event That Brings Them Both Together

**Hands-On, Practical, Problem Solving...Let's Get To Work**

- Exhibition of Industry Leading Exhibitors
- Technical Conference with Papers, Workshops, Panels, Plenary Keynotes and EDI CON University

**October 17-18, 2018**  
**Santa Clara**  
**Convention Center**  
**Santa Clara, California**

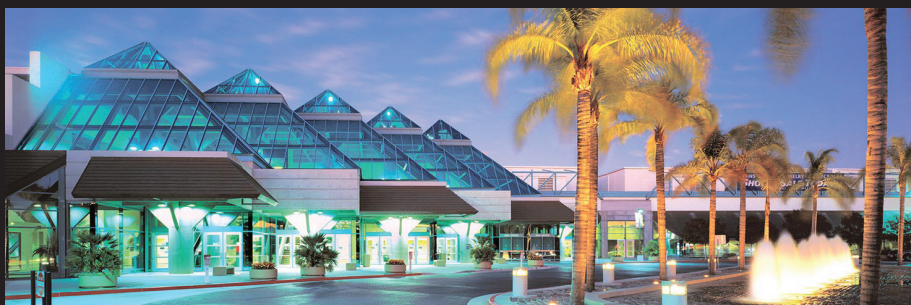



# UNECE REGULATION 10: THE TYPE APPROVAL PROCESS

---

Sponsored by: AMETEK  
Compliance Test Solutions  
[www.ametek-cts.com](http://www.ametek-cts.com)

## **Introduction**

*Testing is only part of the process when it comes to Type Approval, the documentation aspects are as important and often delay granting of approvals, despite having passed the applicable tests.*



**AMETEK**<sup>®</sup>  
COMPLIANCE TEST SOLUTIONS

### UNECE REGULATION 10: THE TYPE APPROVAL PROCESS

#### What is Type Approval and Why Do I Need It?

Type Approval is a formal process whereby a Type Approval Authority issues a certificate confirming that a given Type of vehicle, sub-assembly or component/separate technical unit (STU) meets an applicable requirement for use on the public road. There are many different mandatory requirements for vehicles and components/STUs covering subjects such as [gaseous] emissions, braking, vision, lighting, and, the subject of this blog, electromagnetic compatibility (EMC). For most components/STUs and for vehicles these are legal requirements and appropriate Type Approvals must be obtained before registration and/or sale of the vehicle. It should be noted that this is an over-simplification as there are circumstances where components/STUs do not require Type Approval.

In Europe, there are presently two systems of Type Approval in operation.

The European Community Whole Vehicle Type Approval Directive (ECWVTA) – 2007/46/EC (as last amended by 2017/2400/EU) covers passenger cars, goods vehicles, buses and coaches, motor caravans, trailers, and systems and components. The directive has schemes for low volume/small series manufacturers, operating in the EU or in an individual member state and for individual vehicle approval (IVA).

There are also directives for motorcycles, tricycles and quadricycles (2013/168/EU as amended) and agricultural and forestry vehicles (2013/167/EU as amended).

In all cases these European Community directives (EC and EU) either require 'e' marking or 'E' marking to a delegated UNECE Regulation.

The United Nations European Commission for Europe (UNECE) publishes a series of regulations (currently 143) for systems and components. Type Approval to these regulations require 'E' marking.

The UNECE does not presently have a whole vehicle type approval regulation, however there is one in preparation an outline of which is available at: <http://www.unece.org/fileadmin/DAM/trans/doc/2010/wp29/IWVTA-02-07e.pdf>.

A number of the UNECE Regulations, including R10, have been adopted by the EC Directives and replace former EC Directives covering the same subjects. In the case of EMC, Type Approval to R10 is now the route to compliance superseding 2004/104/EC (as last amended by 2009/19/EC) in November 2014. Thus, the 'e' mark mentioned earlier, has been superseded by the 'E' mark for EMC Type Approval.

#### The Type Approval Process

Under EC Directives and UNECE Regulations the process of Type Approval is essentially the same and comprises the following steps:

- Step 1: Choosing an Approval Authority and Technical Service
- Step 2: Registering for Conformity of Production
- Step 3: Completing the Information Document (Annex 2A/2B)
- Step 4: Agreeing on Worst-Case Test Conditions and Variant Selection with the Technical Service
- Step 5: Performing Tests
- Step 6: Applying for Type Approval
- Step 7: Marking Requirements
- Step 8: Post-Approval

The second and fourth blogs in this series cover Steps 2 and 4 respectively, with subsequent blogs covering the different types of testing set out in the Annexes to R10.05. The final blog will cover Post-Approval.

#### Choosing an Approval Authority and Technical Service

There are [presently] 28 EU Member States that must implement and administer the various EC and EU Directives. Choosing an Approval Authority in any one of these Member States allows free movement of the vehicle, component/STU within the EU.

There are presently 52 Member States that are signatory to the 1958 Agreement, which is the UNECE treaty governing Type Approval. All 28 EU Member States are signatories and an approval granted by any of the 52 Approval Authorities will be accepted by the other 51. The most notable countries that are not signatory to the 1958 Agreement are the United States of America, and China, who operate their own systems.

Technical Services are either departments within the Approval Authority that handle Type Approval for a given subject or delegated third parties (often Test Houses) that handle the technical aspects of the Type Approval on behalf of the Approval Authority. Due to the cost of establishing and maintaining EMC Test Facilities for vehicle and component/STU testing, and the specialized nature of the subject, Approval Authorities usually appoint Technical Services for EMC.

#### Completing the Information Document (Annex 2A/2B)

Before agreeing to worst-casing with the Technical Service, the manufacturer, which in this context means the approval holder, must complete an information document. In the case of a vehicle this is Annex 2A of UNECE R10.05, and in the case of a component or STU Annex 2B.

The information document contains details of the subject of the approval, lists of variants, drawings, circuits, PC board layouts and electrical information. This document



is appended to the approval certificate and forms a part of the Type Approval.

Every product produced under the Type Approval must exactly match what is contained within this document. Any deviation invalidates the Type Approval and could lead to punitive measures from the Approval Authority. The blog on Conformity of Production covers this subject in a little more detail, and the final blog in this series on Post-Approval covers the process of extending the Type Approval to cover changes in production.

### Applying for Type Approval

Once testing has been completed successfully, the Technical Service makes an application to the Approval Authority. The submission is reviewed by the Approval Authority and, assuming there are no problems, issues a Type Approval Certificate with a unique number.

### Marketing Requirements

Section 5 of R10.05 sets out the format of the E mark to be applied to the component/STU and examples are provided in Annex 1. Briefly, this comprises the letter 'E' followed by the number of the Approval Authority issuing the approval (e.g. E1 = Germany, E4 = The Netherlands, E11 = United Kingdom, E13 = Luxembourg, E14 = Switzerland, E22 = Russian Federation, E24 = Ireland, E62 = Egypt) enclosed within a circle followed by '10R' the revision number of the regulation applied, in this case '05' and then the approval number. A schematic can be found in the white paper link at the end of this blog post.

### References

UNECE Regulation 10, Revision 5 (9 October 2014): <https://www.unece.org/fileadmin/DAM/trans/main/wp29/wp29regs/2015/R010r5e.pdf>

UNECE Regulation 10, Revision 5, Amendment 1 (8 October 2016): <https://www.unece.org/fileadmin/DAM/trans/main/wp29/wp29regs/2016/R010r5am1e.pdf>

E/ECE/TRANS/505/Rev.3 (The 1958 Agreement, Revision 3 (14 September 2017)): <https://www.unece.org/fileadmin/DAM/trans/main/wp29/wp29regs/2017/E-ECE-TRANS-505-Rev.3e.pdf>

2007/46/EC, European Community Whole Vehicle Type Approval Directive (Consolidated version including all amendments to 2017/1347/EU): <http://eur-lex.europa.eu/legal-content/EN/TXT/PDF/?uri=CELEX:02007L0046-20170727&from=EN>

2013/167/EU, Agricultural and Forestry Vehicles: <http://eur-lex.europa.eu/legal-content/EN/TXT/PDF/?uri=CELEX:32013R0167&from=EN>

2013/168/EU, Two or Three Wheeled Vehicles and Quadricycles: <http://eur-lex.europa.eu/legal-content/EN/TXT/PDF/?uri=CELEX:32013R0168&from=EN>





# EMC LIVE 2018

## BOOTCAMP

November 14, 2018

## MARK YOUR CALENDARS!

EMC Live 2018 Bootcamp, a fully online, FREE event geared toward EMC, EMI and RFI testing and design, is live November 14\*. Discover new tips and techniques during a full day of technical webinars and product demonstrations, as well as white paper and application note downloads.

▶ REGISTER TODAY AT: [WWW.EMC.LIVE](http://WWW.EMC.LIVE)

*\*Can't attend live? Don't worry! Register now and you'll automatically receive a link to the on-demand version of each presentation following the event.*



# TROUBLESHOOTING EFT

---

Aziz Yuldashev  
aziz.yulda@gmail.com

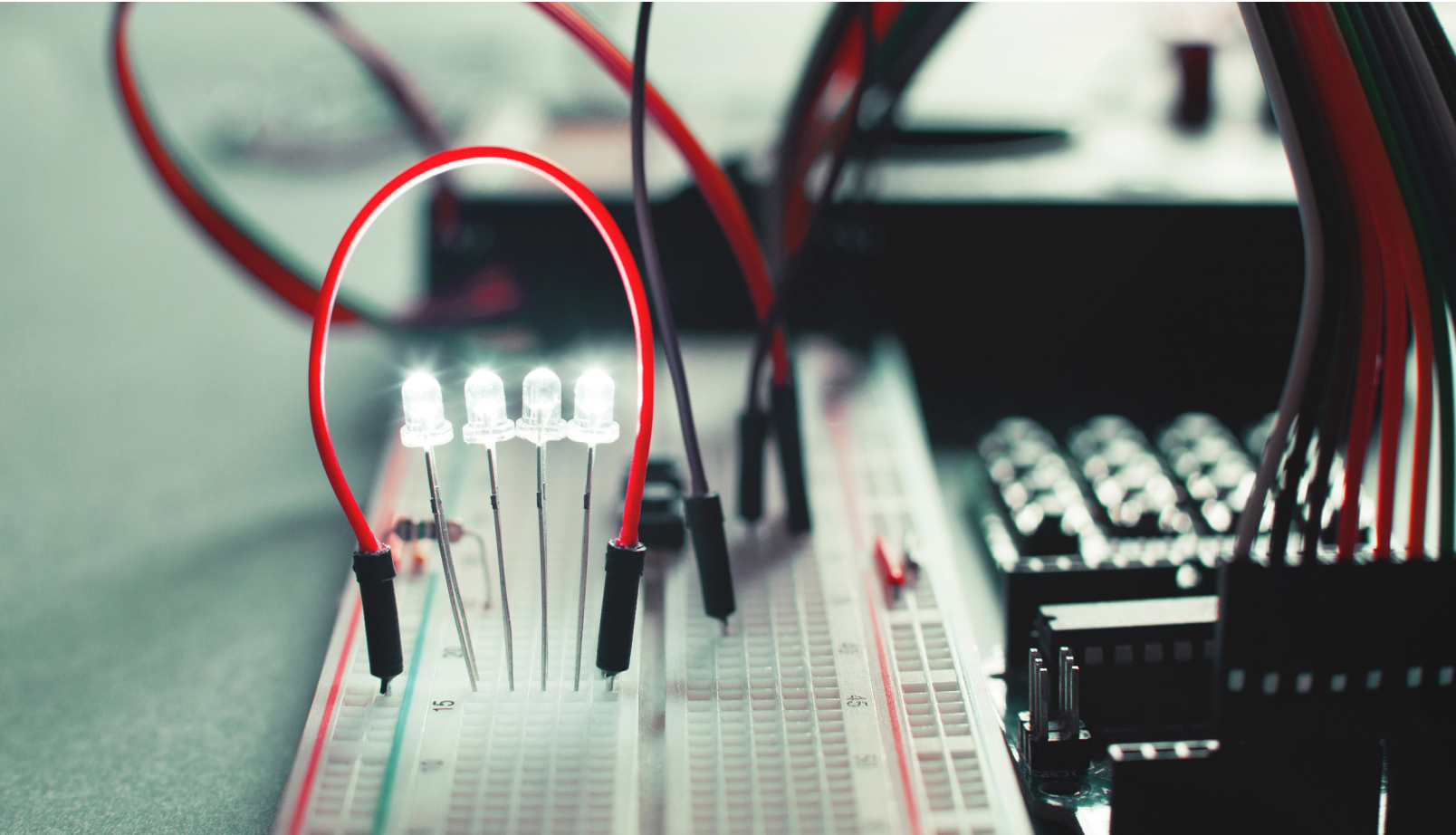

## TROUBLESHOOTING EFT

### EFT Phenomenon

Recently I tested a medical device for EFT susceptibility. The requirement is that the medical device must be immune to EFT bursts generated per IEC 61000-4-4. Per this standard EFT bursts are applied in four steps. For level 4, steps 1 and 2 are +/-2kV at 5kHz, and steps 3 and 4 are +/-2kV at 100kHz. For each step, these bursts are applied at 300ms interval for 60 seconds.

I took the DUT to a testing house for evaluation. EFT bursts were applied onto the AC line, specifically Line plus Neutral to ground. The behavior of the DUT was as follows:

- Physiological signals displayed were distorted making it difficult to read the data.
- The screen was flickering.
- LEDs on the front panel were turning on and off.

This behavior was repeatable with each EFT test and for each EFT test step.

### Troubleshooting EFT

In order to troubleshoot the above described behavior of the DUT to EFT it was necessary to have an EFT test set-up. Troubleshooting in a test house is very expensive as the cost of immunity tests are in the \$250-\$300 per hour. In addition to the cost, one has to bring troubleshooting equipment with them to the test house.

A better solution is to rent an EFT/Surge generator if you don't own one. There are many vendors that carry EFT/Surge generators and can lease them on a week to week or a month to month basis. My preferred location for getting test equipment very quickly is [www.TheEMCShop.com](http://www.TheEMCShop.com). Through this shop I rented the Haefely PSURGE 8000/PIM 110 Ring Wave Impulse Generator for \$875/month. It arrived at our lab within two days of ordering. The equipment came with detailed manual and it was straight forward to set up.

When troubleshooting EMC issues, it is best to start with a troubleshooting plan. Taking a moment and studying the schematic of the problem areas and understanding the circuit is very important. In my case I was dealing with bursts applied to the AC line. I came up with a diagram of the power distribution system. The diagram below shows an example.

### Create a Plan

Creating a plan in a way creates an approach. Having an approach requires a starting point. A good way to start is to have a hypothesis. Once you start troubleshooting you either prove the hypothesis or you reject it.

I based my approach for EFT troubleshooting on the

fact that bursts were injected directly into the line. Looking at the diagram above I could see how bursts could get through isolation barriers via stray capacitance. I thought at first that bursts were getting into the physiological signal processing circuits. So I decided to take the approach of problem area to source path investigation. Based on this approach I came up with the following hypothesis:

- EFT bursts are capacitively coupling through the power supply chain and affecting physiological signals, processors, etc.

Instead of looking at the above diagram as the power distribution block diagram I looked at it as energy travel diagram. Starting from the problem areas, I studied the path of energy travel in order to find the point of distribution. The solution or the fix would be implemented at the distribution point.

Using an oscilloscope I started probing voltage rails that supplied power to the problem areas observed during EFT tests. Keep in mind that because of high dV/dt created by EFT bursts oscilloscopes can be affected and give erroneous results. I would recommend using a floating oscilloscope (battery powered). With the EFT/Surge generator set to +2kV at 5kHz (with EFT burst duration of 15ms) and applying bursts on LN (Line Neutral) to ground I monitored voltages on all physiological signal processing circuits and I saw that the voltages were dropping by about 70% for 15ms at the rate of EFT bursts. Going down the power supply chain showed that VBUS was also dropping.

Finally, the output of the AC/DC open frame switching power supply was also dropping for 15ms. That explained why the DUT was affected by EFT. I rejected the hypothesis. The mystery was the AC/DC power supply. Why was the output voltage dropping?

### The Root Cause

EFT bursts applied on the AC line, which is the primary of the AC/DC transformer were common mode coupling onto the secondary due to the capacitance between the primary winding of the transformer and the secondary winding and due to stray capacitance on the board. When bursts got onto the secondary side, one of the effects they had was a ground bounce.

Given that the power supply is a switching power supply, the microcontroller driving a MOSFET on the DC output was getting into an unknown state when its reference point was experiencing a large dV/dt due to the ground bounce. As a result all pins of the chip were becoming High Z and the MOSFET stopped switching on and the output voltage dropped.

### Choosing an Off the Shelf Power Supply

I looked through the specification documentation for the







MASTER SPONSOR



ROHDE & SCHWARZ

# EMC+SIPI 2018 CONTINUES

## BENEFITS & FEATURES

- Watch Exclusive presentations that are only available online!
- Learn EMC, Signal Integrity and Power Integrity techniques
- Expert technical papers
- Practical EMC+SIPI tutorials



Did you miss the EMC+SIPI 2018 Symposium in Long Beach, California?

Great news – the symposium continues **ONLINE!**

30 tracks (including over 135 individual presentations!) from the live event are available **ON DEMAND**, accessible from your computer, tablet, or phone! **PLUS** enjoy exclusive Online-Only presentations from event sponsors Rohde & Schwarz and Altair!

**EMC+SIPI 2018 Online passes start at just \$99**

[www.2018checkout.emcss.org/online/](http://www.2018checkout.emcss.org/online/)



IEEE

EMC  
SOCIETY



# MEASURING COMMON MODE VERSUS DIFFERENTIAL MODE CONDUCTED EMISSIONS

---

**Kenneth Wyatt**  
Wyatt Technical Services LLC  
ken@emc-seminars.com

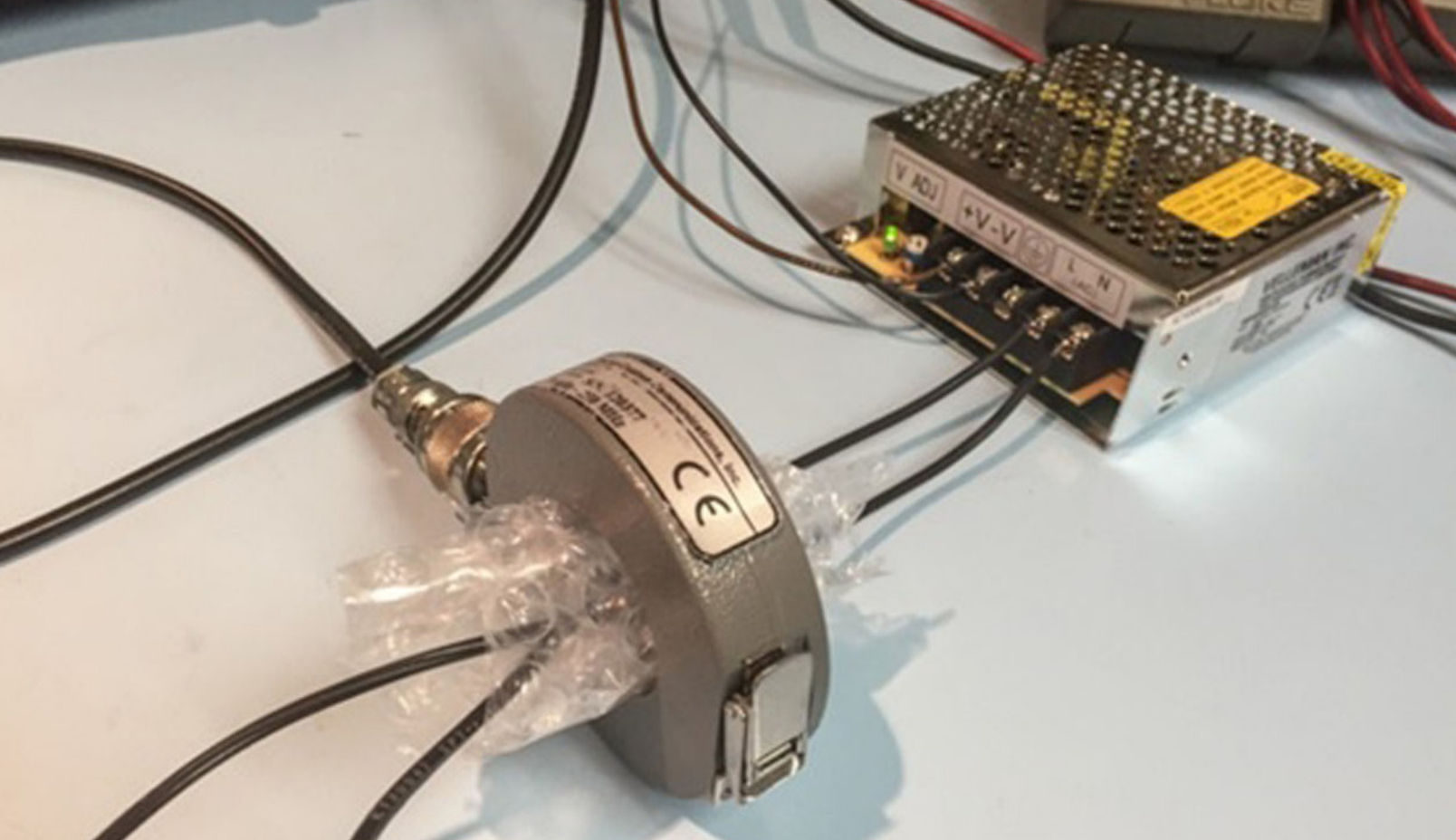

## MEASURING COMMON MODE VERSUS DIFFERENTIAL MODE CONDUCTED EMISSIONS

When faced with excessive conducted emissions from switching power supplies, one of the first things to investigate, and to determine the adequacy of, is the power line filter. Line-powered switching supplies generally have both common mode and differential mode sections of the filter as shown in the generalized schematic in *Figure 1*.

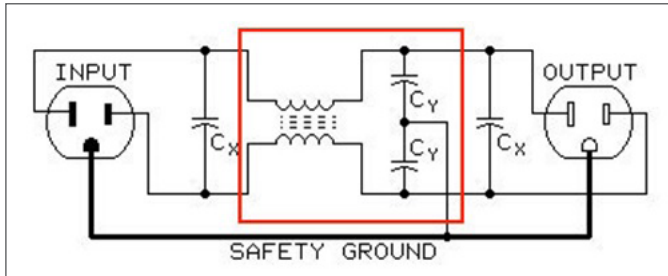

**Figure 1** - A common form of power line filter. The red box indicates the common mode filter components and the Cx capacitors filter differential mode.

When using a line impedance stabilization network (LISN), we are actually measuring the sum of the common mode and differential mode conducted voltages. An example is shown in *Figure 2*. We're measuring a Velleman 12V / 2A switching supply (model PSIN02512N). The overall emissions weren't too bad, so I zoomed in to measure from "0" to 2 MHz, so I could observe the noise better.

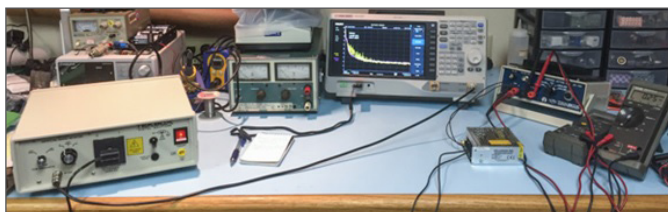

**Figure 2** - A temporary test setup to measure conducted emissions using a LISN.

The result may be seen in *Figure 3*. Note the difference in measured values between line and neutral. Well-designed supplies usually have fairly equal measurements, so there is obviously some imbalance within the filter circuitry.

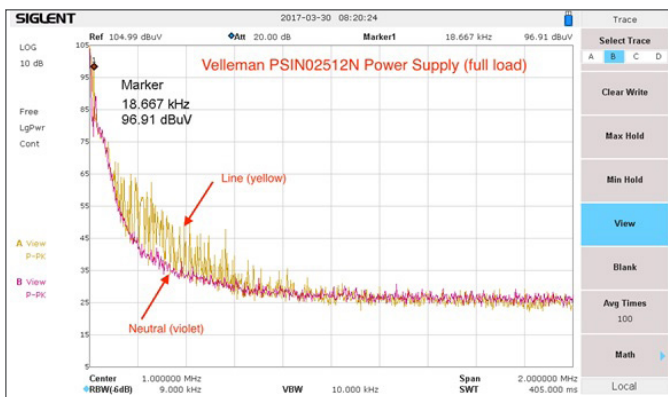

**Figure 3** - Measurement of the conducted emissions using a LISN.

In order to separately break out the differential mode and common mode emissions, we'll use a current probe. Note that this is not directly comparable to the LISN measurement, which is a voltage, but it will still provide some useful information on which is noisiest.

We're all probably familiar with the procedure for measuring common mode currents. We simply clamp the current probe around both line and neutral wires and make the measurement. Remember, common mode currents flow out both wires in the same direction and normally end up radiating as well as conducting back into the power line. This is shown in the yellow trace of *Figure 6*.

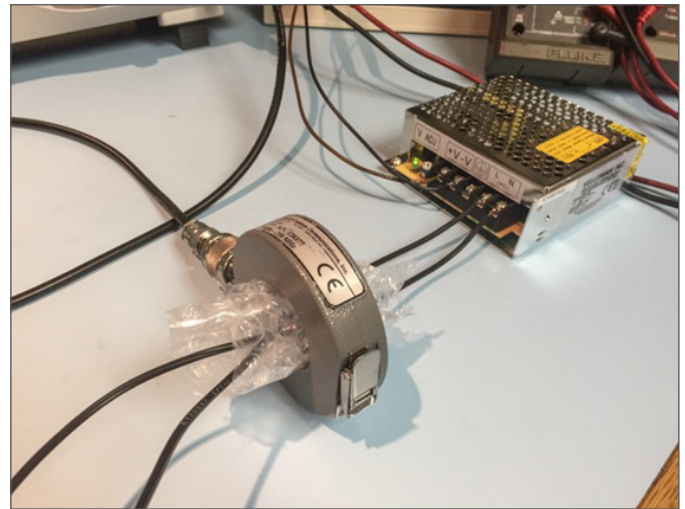

**Figure 4** - Measurement of common mode currents in both the line and neutral wires. I usually stuff some insulation around the wires to keep them from touching the metal case of the current probe.

On the other hand, to measure differential mode currents and cancel out the common mode currents, we need to configure the wires such that they feed through the current probe in opposite directions. Note that when we do this, the voltage reading will be twice the actual differential mode current (6 dB higher). This is shown in the violet trace in *Figure 6*.

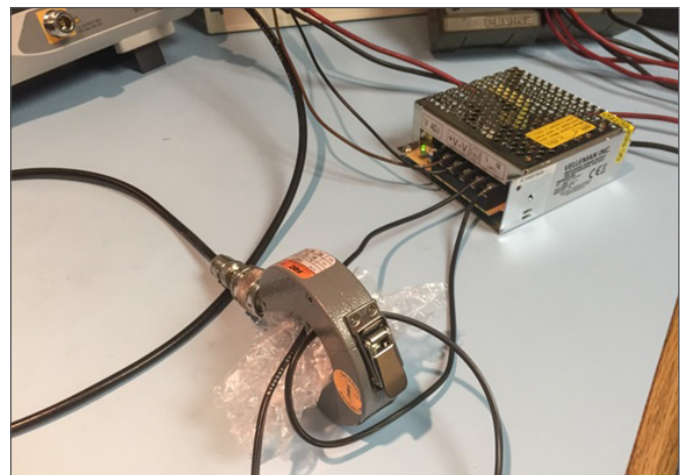

**Figure 5** - Configuration of the wires to measure differential mode currents.



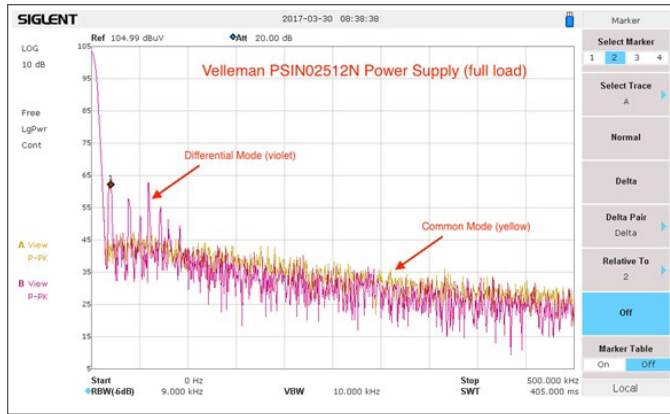

Figure 6 – A measurement of common mode (yellow trace) and differential mode (violet trace). Note how the differential mode includes the dominant noise.

Note that in *Figure 6*, we see that the differential mode currents are substantially larger than the common mode currents. This suggests the common mode section of the line filter is adequate, while the differential mode filtering could use some additional work. For example, a small series inductor in the line side would provide more impedance for the X-capacitor (Cx) to work with.

This technique of isolating the common mode and differential mode components of conducted noise currents may be a valuable tool for your troubleshooting toolbox.

**Author Bio**

Kenneth Wyatt is president and principal consultant of Wyatt Technical Services LLC, as well as the senior technical editor for Interference Technology. He has worked in the field of EMC engineering for 30 years. His specialty is EMI troubleshooting and pre-compliance testing and is a co-author of the popular EMC Pocket Guide and RFI Radio Frequency Interference Pocket Guide. He also coauthored the book with Patrick André, EMI Troubleshooting Cookbook for Product Designers, with forward by Henry Ott. He is widely published and authored The EMC Blog hosted by EDN.com for nearly three years. Kenneth is a senior member of the IEEE and a long time member of the EMC Society.

► He may be contacted at:

ken@emc-seminars.com or  
kwyatt@interferencetechnology.com

► Check out his web site for more technical information, training schedules, and links:

www.emc-seminars.com

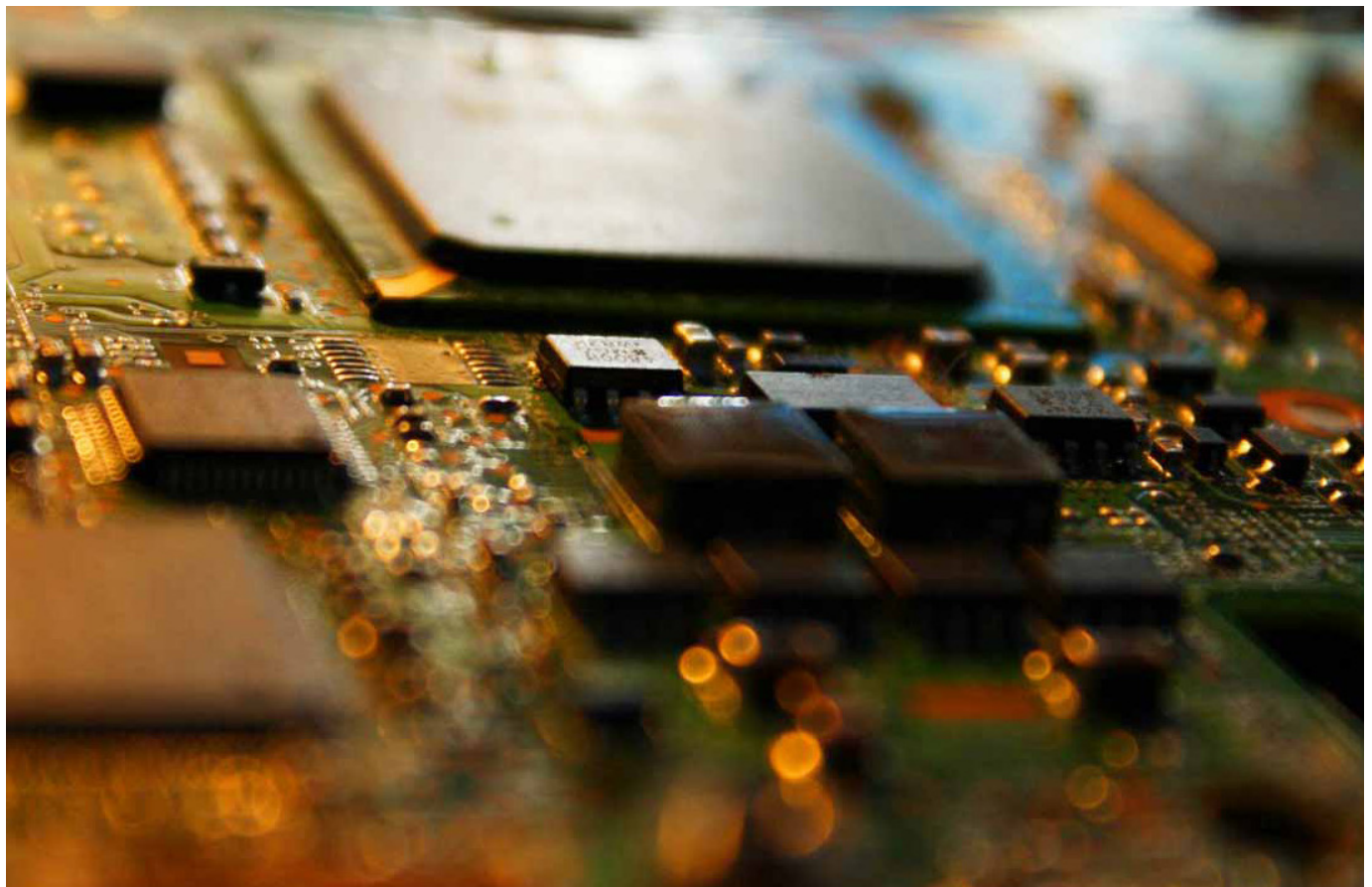





Engineered Marketing For  
The Electronics Industry

# Understand your customers' digital footprints to better understand their journey.

- Lead Qualification
- Lead Generation
- Audience Development
- Online Events
- Content Creation
- Technology Implementation
- Big Data Translation
- ...and MORE!

Start your journey today!

please visit

[item.media](http://item.media)



# COMMON COMMERCIAL EMC STANDARDS

## Commercial Electromagnetic Compatibility (EMC) Standards

| ANSI            |                                                                                                                                      |
|-----------------|--------------------------------------------------------------------------------------------------------------------------------------|
| Document Number | Title                                                                                                                                |
| C63.4           | Methods of Measurement of Radio-Noise Emissions from Low-Voltage Electrical and Electronic Equipment in the Range of 9 kHz to 40 GHz |

| IEC             |                                                                                                                                                                                              |
|-----------------|----------------------------------------------------------------------------------------------------------------------------------------------------------------------------------------------|
| Document Number | Title                                                                                                                                                                                        |
| IEC 60050-161   | International Electrotechnical Vocabulary. Chapter 161: Electromagnetic compatibility                                                                                                        |
| IEC 60060-1     | High-voltage test techniques. Part 1: General definitions and test requirements                                                                                                              |
| IEC 60060-2     | High-voltage test techniques - Part 2: Measuring systems                                                                                                                                     |
| IEC 60060-3     | High-voltage test techniques - Part 3: Definitions and requirements for on-site testing                                                                                                      |
| IEC 60118-13    | Electroacoustics - Hearing aids - Part 13: Electromagnetic compatibility (EMC)                                                                                                               |
| IEC 60255-26    | Measuring relays and protection equipment - Part 26: Electromagnetic compatibility requirements                                                                                              |
| IEC 60364-4-44  | Low-voltage electrical installations - Part 4-44: Protection for safety - Protection against voltage disturbances and electromagnetic disturbance                                            |
| IEC 60469       | Transitions, pulses and related waveforms - Terms, definitions and algorithms                                                                                                                |
| IEC 60533       | Electrical and electronic installations in ships - Electromagnetic compatibility (EMC) - Ships with a metallic hull                                                                          |
| IEC 60601-1-2   | Medical electrical equipment - Part 1-2: General requirements for basic safety and essential performance - Collateral Standard: Electromagnetic disturbances - Requirements and tests        |
| IEC 60601-2-2   | Medical electrical equipment - Part 2-2: Particular requirements for the basic safety and essential performance of high frequency surgical equipment and high frequency surgical accessories |
| IEC 60601-4-2   | Medical electrical equipment - Part 4-2: Guidance and interpretation - Electromagnetic immunity: performance of medical electrical equipment and medical electrical systems                  |
| IEC 60728-2     | Cabled distribution systems for television and sound signals - Part 2: Electromagnetic compatibility for equipment                                                                           |
| IEC 60728-12    | Cabled distribution systems for television and sound signals - Part 12: Electromagnetic compatibility of systems                                                                             |

| IEC (continued)  |                                                                                                                                                                                                                           |
|------------------|---------------------------------------------------------------------------------------------------------------------------------------------------------------------------------------------------------------------------|
| Document Number  | Title                                                                                                                                                                                                                     |
| IEC/TS 60816     | Guide on methods of measurement of short duration transients on low-voltage power and signal lines                                                                                                                        |
| IEC 60870-2-1    | Telecontrol equipment and systems - Part 2: Operating conditions - Section 1: Power supply and electromagnetic compatibility                                                                                              |
| IEC 60940        | Guidance information on the application of capacitors, resistors, inductors and complete filter units for electromagnetic interference suppression                                                                        |
| IEC 60974-10     | Arc welding equipment - Part 10: Electromagnetic compatibility (EMC) requirements                                                                                                                                         |
| IEC/TR 61000-1-1 | Electromagnetic compatibility (EMC) - Part 1: General - Section 1: Application and interpretation of fundamental definitions and terms                                                                                    |
| IEC/TS 61000-1-2 | Electromagnetic compatibility (EMC) - Part 1-2: General - Methodology for the achievement of the functional safety of electrical and electronic equipment with regard to electromagnetic phenomena                        |
| IEC/TR 61000-1-3 | Electromagnetic compatibility (EMC) - Part 1-3: General - The effects of high-altitude EMP (HEMP) on civil equipment and systems                                                                                          |
| IEC/TR 61000-1-4 | Electromagnetic compatibility (EMC) - Part 1-4: General - Historical rationale for the limitation of power-frequency conducted harmonic current emissions from equipment, in the frequency range up to 2 kHz              |
| IEC/TR 61000-1-5 | Electromagnetic compatibility (EMC) - Part 1-5: General - High power electromagnetic (HPEM) effects on civil systems                                                                                                      |
| IEC/TR 61000-1-6 | Electromagnetic compatibility (EMC) - Part 1-6: General - Guide to the assessment of measurement uncertainty                                                                                                              |
| IEC/TR 61000-1-7 | Electromagnetic compatibility (EMC) - Part 1-7: General - Power factor in single-phase systems under non-sinusoidal conditions                                                                                            |
| IEC/TR 61000-2-1 | Electromagnetic compatibility (EMC) - Part 2: Environment - Section 1: Description of the environment - Electromagnetic environment for low-frequency conducted disturbances and signaling in public power supply systems |
| IEC 61000-2-2    | Electromagnetic compatibility (EMC) - Part 2-2: Environment - Compatibility levels for low-frequency conducted disturbances and signaling in public low-voltage power supply systems                                      |
| IEC/TR 61000-2-3 | Electromagnetic compatibility (EMC) - Part 2: Environment - Section 3: Description of the environment - Radiated and non-network-frequency-related conducted phenomena                                                    |

| IEC (continued)   |                                                                                                                                                                                                                                                                 |
|-------------------|-----------------------------------------------------------------------------------------------------------------------------------------------------------------------------------------------------------------------------------------------------------------|
| Document Number   | Title                                                                                                                                                                                                                                                           |
| IEC 61000-2-4     | Electromagnetic compatibility (EMC) - Part 2-4: Environment - Compatibility levels in industrial plants for low-frequency conducted disturbances                                                                                                                |
| IEC/TS 61000-2-5  | Electromagnetic compatibility (EMC) - Part 2: Environment - Section 5: Classification of electromagnetic environments. Basic EMC publication                                                                                                                    |
| IEC/TR 61000-2-6  | Electromagnetic compatibility (EMC) - Part 2: Environment - Section 6: Assessment of the emission levels in the power supply of industrial plants as regards low-frequency conducted disturbances                                                               |
| IEC/TR 61000-2-7  | Electromagnetic compatibility (EMC) - Part 2: Environment - Section 7: Low frequency magnetic fields in various environments                                                                                                                                    |
| IEC/TR 61000-2-8  | Electromagnetic compatibility (EMC) - Part 2-8: Environment - Voltage dips and short interruptions on public electric power supply systems with statistical measurement results                                                                                 |
| IEC 61000-2-9     | Electromagnetic compatibility (EMC) - Part 2: Environment - Section 9: Description of HEMP environment - Radiated disturbance. Basic EMC publication                                                                                                            |
| IEC 61000-2-10    | Electromagnetic compatibility (EMC) - Part 2-10: Environment - Description of HEMP environment - Conducted disturbance                                                                                                                                          |
| IEC 61000-2-11    | Electromagnetic compatibility (EMC) - Part 2-11: Environment - Classification of HEMP environments                                                                                                                                                              |
| IEC 61000-2-12    | Electromagnetic compatibility (EMC) - Part 2-12: Environment - Compatibility levels for low-frequency conducted disturbances and signaling in public medium-voltage power supply systems                                                                        |
| IEC 61000-2-13    | Electromagnetic compatibility (EMC) - Part 2-13: Environment - High-power electromagnetic (HPEM) environments - Radiated and conducted                                                                                                                          |
| IEC/TR 61000-2-14 | Electromagnetic compatibility (EMC) - Part 2-14: Environment - Overvoltages on public electricity distribution networks                                                                                                                                         |
| IEC 61000-3-2     | Electromagnetic compatibility (EMC) - Part 3-2: Limits - Limits for harmonic current emissions (equipment input current $\leq$ 16 A per phase)                                                                                                                  |
| IEC 61000-3-3     | Electromagnetic compatibility (EMC) - Part 3-3: Limits - Limitation of voltage changes, voltage fluctuations and flicker in public low-voltage supply systems, for equipment with rated current $\leq$ 16 A per phase and not subject to conditional connection |
| IEC/TS 61000-3-4  | Electromagnetic compatibility (EMC) - Part 3-4: Limits - Limitation of emission of harmonic currents in low-voltage power supply systems for equipment with rated current greater than 16 A                                                                     |
| IEC/TS 61000-3-5  | Electromagnetic compatibility (EMC) - Part 3: Limits - Section 5: Limitation of voltage fluctuations and flicker in low-voltage power supply systems for equipment with rated current greater than 16 A                                                         |
| IEC/TR 61000-3-6  | Electromagnetic compatibility (EMC) - Part 3: Limits - Section 6: Assessment of emission limits for distorting loads in MV and HV power systems - Basic EMC publication                                                                                         |
| IEC/TR 61000-3-7  | Electromagnetic compatibility (EMC) - Part 3: Limits - Section 7: Assessment of emission limits for fluctuating loads in MV and HV power systems - Basic EMC publication                                                                                        |
| IEC 61000-3-8     | Electromagnetic compatibility (EMC) - Part 3: Limits - Section 8: Signaling on low-voltage electrical installations - Emission levels, frequency bands and electromagnetic disturbance levels                                                                   |
| IEC 61000-3-11    | Electromagnetic compatibility (EMC) - Part 3-11: Limits - Limitation of voltage changes, voltage fluctuations and flicker in public low-voltage supply systems - Equipment with rated current $\leq$ 75 A and subject to conditional connection                 |

| IEC (continued)   |                                                                                                                                                                                                                               |
|-------------------|-------------------------------------------------------------------------------------------------------------------------------------------------------------------------------------------------------------------------------|
| Document Number   | Title                                                                                                                                                                                                                         |
| IEC 61000-3-12    | Electromagnetic compatibility (EMC) - Part 3-12: Limits - Limits for harmonic currents produced by equipment connected to public low-voltage systems with input current $>16$ A and $\leq 75$ A per phase                     |
| IEC/TR 61000-3-13 | Electromagnetic compatibility (EMC) - Part 3-13: Limits - Assessment of emission limits for the connection of unbalanced installations to MV, HV and EHV power systems                                                        |
| IEC/TR 61000-3-14 | Electromagnetic compatibility (EMC) - Part 3-14: Assessment of emission limits for harmonics, interharmonics, voltage fluctuations and unbalance for the connection of disturbing installations to LV power systems           |
| IEC/TR 61000-3-15 | Electromagnetic compatibility (EMC) - Part 3-15: Limits - Assessment of low frequency electromagnetic immunity and emission requirements for dispersed generation systems in LV network                                       |
| IEC TR 61000-4-1  | Electromagnetic compatibility (EMC) - Part 4-1: Testing and measurement techniques - Overview of IEC 61000-4 series                                                                                                           |
| IEC 61000-4-2     | Electromagnetic compatibility (EMC) - Part 4-2: Testing and measurement techniques - Electrostatic discharge immunity test                                                                                                    |
| IEC 61000-4-3     | Electromagnetic compatibility (EMC) - Part 4-3: Testing and measurement techniques - Radiated, radio-frequency, electromagnetic field immunity test                                                                           |
| IEC 61000-4-4     | Electromagnetic compatibility (EMC) - Part 4-4: Testing and measurement techniques - Electrical fast transient/burst immunity test                                                                                            |
| IEC 61000-4-5     | Electromagnetic compatibility (EMC) - Part 4-5: Testing and measurement techniques - Surge immunity test                                                                                                                      |
| IEC 61000-4-6     | Electromagnetic compatibility (EMC) - Part 4-6: Testing and measurement techniques - Immunity to conducted disturbances, induced by radio-frequency fields                                                                    |
| IEC 61000-4-7     | Electromagnetic compatibility (EMC) - Part 4-7: Testing and measurement techniques - General guide on harmonics and interharmonics measurements and instrumentation, for power supply systems and equipment connected thereto |
| IEC 61000-4-8     | Electromagnetic compatibility (EMC) - Part 4-8: Testing and measurement techniques - Power frequency magnetic field immunity test                                                                                             |
| IEC 61000-4-9     | Electromagnetic compatibility (EMC) - Part 4-9: Testing and measurement techniques - Impulse magnetic field immunity test                                                                                                     |
| IEC 61000-4-10    | Electromagnetic compatibility (EMC) - Part 4-10: Testing and measurement techniques - Damped oscillatory magnetic field immunity test                                                                                         |
| IEC 61000-4-11    | Electromagnetic compatibility (EMC) - Part 4-11: Testing and measurement techniques - Voltage dips, short interruptions and voltage variations immunity tests                                                                 |
| IEC 61000-4-12    | Electromagnetic compatibility (EMC) - Part 4-12: Testing and measurement techniques - Ring wave immunity test                                                                                                                 |
| IEC 61000-4-13    | Electromagnetic compatibility (EMC) - Part 4-13: Testing and measurement techniques - Harmonics and interharmonics including mains signaling at a.c. power port, low frequency immunity tests                                 |
| IEC 61000-4-14    | Electromagnetic compatibility (EMC) - Part 4-14: Testing and measurement techniques - Voltage fluctuation immunity test                                                                                                       |
| IEC 61000-4-15    | Electromagnetic compatibility (EMC) - Part 4: Testing and measurement techniques - Section 15: Flickermeter - Functional and design specifications                                                                            |
| IEC 61000-4-16    | Electromagnetic compatibility (EMC) - Part 4-16: Testing and measurement techniques - Test for immunity to conducted, common mode disturbances in the frequency range 0 Hz to 150 kHz                                         |



| IEC (continued)   |                                                                                                                                                                                                                                 |
|-------------------|---------------------------------------------------------------------------------------------------------------------------------------------------------------------------------------------------------------------------------|
| Document Number   | Title                                                                                                                                                                                                                           |
| IEC 61000-4-17    | Electromagnetic compatibility (EMC) - Part 4-17: Testing and measurement techniques - Ripple on d.c. input power port immunity test                                                                                             |
| IEC 61000-4-18    | Electromagnetic compatibility (EMC) - Part 4-18: Testing and measurement techniques - Damped oscillatory wave immunity test                                                                                                     |
| IEC 61000-4-19    | Electromagnetic compatibility (EMC) - Part 4-19: Testing and measurement techniques - Test for immunity to conducted, differential mode disturbances and signalling in the frequency range 2 kHz to 150 kHz at a.c. power ports |
| IEC 61000-4-20    | Electromagnetic compatibility (EMC) - Part 4-20: Testing and measurement techniques - Emission and immunity testing in transverse electromagnetic (TEM) waveguides                                                              |
| IEC 61000-4-21    | Electromagnetic compatibility (EMC) - Part 4-21: Testing and measurement techniques - Reverberation chamber test methods                                                                                                        |
| IEC 61000-4-22    | Electromagnetic compatibility (EMC) - Part 4-22: Testing and measurement techniques - Radiated emissions and immunity measurements in fully anechoic rooms (FARs)                                                               |
| IEC 61000-4-23    | Electromagnetic compatibility (EMC) - Part 4-23: Testing and measurement techniques - Test methods for protective devices for HEMP and other radiated disturbances                                                              |
| IEC 61000-4-24    | Electromagnetic compatibility (EMC) - Part 4-24: Testing and measurement techniques - Test methods for protective devices for HEMP conducted disturbance                                                                        |
| IEC 61000-4-25    | Electromagnetic compatibility (EMC) - Part 4-25: Testing and measurement techniques - HEMP immunity test methods for equipment and systems                                                                                      |
| IEC 61000-4-27    | Electromagnetic compatibility (EMC) - Part 4-27: Testing and measurement techniques - Unbalance, immunity test                                                                                                                  |
| IEC 61000-4-28    | Electromagnetic compatibility (EMC) - Part 4-28: Testing and measurement techniques - Variation of power frequency, immunity test                                                                                               |
| IEC 61000-4-29    | Electromagnetic compatibility (EMC) - Part 4-29: Testing and measurement techniques - Voltage dips, short interruptions and voltage variations on d.c. input power port immunity tests                                          |
| IEC 61000-4-30    | Electromagnetic compatibility (EMC) - Part 4-30: Testing and measurement techniques - Power quality measurement methods                                                                                                         |
| IEC 61000-4-31    | Electromagnetic compatibility (EMC) - Part 4-31: Testing and measurement techniques - AC mains ports broadband conducted disturbance immunity test                                                                              |
| IEC/TR 61000-4-32 | Electromagnetic compatibility (EMC) - Part 4-32: Testing and measurement techniques - High-altitude electromagnetic pulse (HEMP) simulator compendium                                                                           |
| IEC 61000-4-33    | Electromagnetic compatibility (EMC) - Part 4-33: Testing and measurement techniques - Measurement methods for high-power transient parameters                                                                                   |
| IEC 61000-4-34    | Electromagnetic compatibility (EMC) - Part 4-34: Testing and measurement techniques - Voltage dips, short interruptions and voltage variations immunity tests for equipment with input current more than 16 A per phase         |
| IEC TR 61000-4-35 | Electromagnetic compatibility (EMC) - Part 4-35: Testing and measurement techniques - HPEM simulator compendium                                                                                                                 |
| IEC 61000-4-36    | Electromagnetic compatibility (EMC) - Part 4-36: Testing and measurement techniques - IEMI immunity test methods for equipment and systems                                                                                      |
| IEC TR 61000-4-37 | Electromagnetic compatibility (EMC) - Calibration and verification protocol for harmonic emission compliance test systems                                                                                                       |
| IEC TR 61000-4-38 | Electromagnetic compatibility (EMC) - Part 4-38: Testing and measurement techniques - Test, verification and calibration protocol for voltage fluctuation and flicker compliance test systems                                   |

| IEC (continued)  |                                                                                                                                                                                                                                                                                               |
|------------------|-----------------------------------------------------------------------------------------------------------------------------------------------------------------------------------------------------------------------------------------------------------------------------------------------|
| Document Number  | Title                                                                                                                                                                                                                                                                                         |
| IEC/TR 61000-5-1 | Electromagnetic compatibility (EMC) - Part 5: Installation and mitigation guidelines - Section 1: General considerations - Basic EMC publication                                                                                                                                              |
| IEC/TR 61000-5-2 | Electromagnetic compatibility (EMC) - Part 5: Installation and mitigation guidelines - Section 2: Earthing and cabling                                                                                                                                                                        |
| IEC/TR 61000-5-3 | Electromagnetic compatibility (EMC) - Part 5-3: Installation and mitigation guidelines - HEMP protection concepts                                                                                                                                                                             |
| IEC/TS 61000-5-4 | Electromagnetic compatibility (EMC) - Part 5: Installation and mitigation guidelines - Section 4: Immunity to HEMP - Specifications for protective devices against HEMP radiated disturbance. Basic EMC Publication                                                                           |
| IEC 61000-5-5    | Electromagnetic compatibility (EMC) - Part 5: Installation and mitigation guidelines - Section 5: Specification of protective devices for HEMP conducted disturbance. Basic EMC Publication                                                                                                   |
| IEC/TR 61000-5-6 | Electromagnetic compatibility (EMC) - Part 5-6: Installation and mitigation guidelines - Mitigation of external EM influences                                                                                                                                                                 |
| IEC 61000-5-7    | Electromagnetic compatibility (EMC) - Part 5-7: Installation and mitigation guidelines - Degrees of protection provided by enclosures against electromagnetic disturbances (EM code)                                                                                                          |
| IEC 61000-5-8    | Electromagnetic compatibility (EMC) - Part 5-8: Installation and mitigation guidelines - HEMP protection methods for the distributed infrastructure                                                                                                                                           |
| IEC 61000-5-9    | Electromagnetic compatibility (EMC) - Part 5-9: Installation and mitigation guidelines - System-level susceptibility assessments for HEMP and HPEM                                                                                                                                            |
| IEC 61000-6-1    | Electromagnetic compatibility (EMC) - Part 6-1: Generic standards - Immunity standard for residential, commercial and light-industrial environments                                                                                                                                           |
| IEC 61000-6-2    | Electromagnetic compatibility (EMC) - Part 6-2: Generic standards - Immunity standard for industrial environments                                                                                                                                                                             |
| IEC 61000-6-3    | Electromagnetic compatibility (EMC) - Part 6-3: Generic standards - Emission standard for residential, commercial and light-industrial environments                                                                                                                                           |
| IEC 61000-6-4    | Electromagnetic compatibility (EMC) - Part 6-4: Generic standards - Emission standard for industrial environments                                                                                                                                                                             |
| IEC 61000-6-5    | Electromagnetic compatibility (EMC) - Part 6-5: Generic standards - Immunity for power station and substation environments                                                                                                                                                                    |
| IEC 61000-6-6    | Electromagnetic compatibility (EMC) - Part 6-6: Generic standards - HEMP immunity for indoor equipment                                                                                                                                                                                        |
| IEC 61000-6-7    | Electromagnetic compatibility (EMC) - Part 6-7: Generic standards - Immunity requirements for equipment intended to perform functions in a safety-related system (functional safety) in industrial locations                                                                                  |
| IEC 61326-1      | Electrical equipment for measurement, control and laboratory use - EMC requirements - Part 1: General requirements                                                                                                                                                                            |
| IEC 61326-2-1    | Electrical equipment for measurement, control and laboratory use - EMC requirements - Part 2-1: Particular requirements - Test configurations, operational conditions and performance criteria for sensitive test and measurement equipment for EMC unprotected applications                  |
| IEC 61326-2-2    | Electrical equipment for measurement, control and laboratory use - EMC requirements - Part 2-2: Particular requirements - Test configurations, operational conditions and performance criteria for portable test, measuring and monitoring equipment used in low-voltage distribution systems |

| IEC (continued) |                                                                                                                                                                                                                                                                                                                                    |
|-----------------|------------------------------------------------------------------------------------------------------------------------------------------------------------------------------------------------------------------------------------------------------------------------------------------------------------------------------------|
| Document Number | Title                                                                                                                                                                                                                                                                                                                              |
| IEC 61326-2-3   | Electrical equipment for measurement, control and laboratory use - EMC requirements - Part 2-3: Particular requirements - Test configuration, operational conditions and performance criteria for transducers with integrated or remote signal conditioning                                                                        |
| IEC 61326-2-4   | Electrical equipment for measurement, control and laboratory use - EMC requirements - Part 2-4: Particular requirements - Test configurations, operational conditions and performance criteria for insulation monitoring devices according to IEC 61557-8 and for equipment for insulation fault location according to IEC 61557-9 |
| IEC 61326-2-5   | Electrical equipment for measurement, control and laboratory use - EMC requirements - Part 2-5: Particular requirements - Test configurations, operational conditions and performance criteria for field devices with field bus interfaces according to IEC 61784-1                                                                |
| IEC 61326-2-6   | Electrical equipment for measurement, control and laboratory use - EMC requirements - Part 2-6: Particular requirements - In vitro diagnostic (IVD) medical equipment                                                                                                                                                              |
| IEC 61326-3-1   | Electrical equipment for measurement, control and laboratory use - EMC requirements - Part 3-1: Immunity requirements for safety-related systems and for equipment intended to perform safety-related functions (functional safety) - General industrial applications                                                              |
| IEC 61326-3-2   | Electrical equipment for measurement, control and laboratory use - EMC requirements - Part 3-2: Immunity requirements for safety-related systems and for equipment intended to perform safety-related functions (functional safety) - Industrial applications with specified electromagnetic environment                           |
| IEC 61340-3-1   | Electrostatics - Part 3-1: Methods for simulation of electrostatic effects - Human body model (HBM) electrostatic discharge test waveforms                                                                                                                                                                                         |
| IEC 61543       | Residual current-operated protective devices (RCDs) for household and similar use - Electromagnetic compatibility                                                                                                                                                                                                                  |
| IEC 61800-3     | Adjustable speed electrical power drive systems - Part 3: EMC requirements and specific test methods                                                                                                                                                                                                                               |
| IEC 61967-1     | Integrated circuits - Measurement of electromagnetic emissions, 150 kHz to 1 GHz - Part 1: General conditions and definitions                                                                                                                                                                                                      |
| IEC 62040-2     | Uninterruptible power systems (UPS) - Part 2: Electromagnetic compatibility (EMC) requirements                                                                                                                                                                                                                                     |
| IEC 62041       | Power transformers, power supply units, reactors and similar products - EMC requirements                                                                                                                                                                                                                                           |
| IEC 62153-4-0   | Metallic communication cable test methods - Part 4-0: Electromagnetic compatibility (EMC) - Relationship between surface transfer impedance and screening attenuation, recommended limits                                                                                                                                          |
| IEC 62153-4-1   | Metallic communication cable test methods - Part 4-1: Electromagnetic compatibility (EMC) - Introduction to electromagnetic screening measurements                                                                                                                                                                                 |
| IEC 62153-4-2   | Metallic communication cable test methods - Part 4-2: Electromagnetic compatibility (EMC) - Screening and coupling attenuation - Injection clamp method                                                                                                                                                                            |
| IEC 62153-4-3   | Metallic communication cable test methods - Part 4-3: Electromagnetic compatibility (EMC) - Surface transfer impedance - Triaxial method                                                                                                                                                                                           |
| IEC 62153-4-4   | Metallic communication cable test methods - Part 4-4: Electromagnetic compatibility (EMC) - Test method for measuring of the screening attenuation as up to and above 3 GHz, triaxial method                                                                                                                                       |
| IEC 62153-4-5   | Metallic communication cables test methods - Part 4-5: Electromagnetic compatibility (EMC) - Coupling or screening attenuation - Absorbing clamp method                                                                                                                                                                            |

| IEC (continued) |                                                                                                                                                                                                                                                                                          |
|-----------------|------------------------------------------------------------------------------------------------------------------------------------------------------------------------------------------------------------------------------------------------------------------------------------------|
| Document Number | Title                                                                                                                                                                                                                                                                                    |
| IEC 62153-4-6   | Metallic communication cable test methods - Part 4-6: Electromagnetic compatibility (EMC) - Surface transfer impedance - Line injection method                                                                                                                                           |
| IEC 62153-4-7   | Metallic communication cable test methods - Part 4-7: Electromagnetic compatibility (EMC) - Test method for measuring of transfer impedance ZT and screening attenuation aS or coupling attenuation aC of connectors and assemblies up to and above 3 GHz - Triaxial tube in tube method |
| IEC 62153-4-8   | Metallic communication cable test methods - Part 4-8: Electromagnetic compatibility (EMC) - Capacitive coupling admittance                                                                                                                                                               |
| IEC 62153-4-9   | Metallic communication cable test methods - Part 4-9: Electromagnetic compatibility (EMC) - Coupling attenuation of screened balanced cables, triaxial method                                                                                                                            |
| IEC 62153-4-10  | Metallic communication cable test methods - Part 4-10: Electromagnetic compatibility (EMC) - Transfer impedance and screening attenuation of feed-throughs and electromagnetic gaskets - Double coaxial test method                                                                      |
| IEC 62153-4-11  | Metallic communication cable test methods - Part 4-11: Electromagnetic compatibility (EMC) - Coupling attenuation or screening attenuation of patch cords, coaxial cable assemblies, pre-connectorized cables - Absorbing clamp method                                                   |
| IEC 62153-4-12  | Metallic communication cable test methods - Part 4-12: Electromagnetic compatibility (EMC) - Coupling attenuation or screening attenuation of connecting hardware - Absorbing clamp method                                                                                               |
| IEC 62153-4-13  | Metallic communication cable test methods - Part 4-13: Electromagnetic compatibility (EMC) - Coupling attenuation of links and channels (laboratory conditions) - Absorbing clamp method                                                                                                 |
| IEC 62153-4-14  | Metallic communication cable test methods - Part 4-14: Electromagnetic compatibility (EMC) - Coupling attenuation of cable assemblies (Field conditions) absorbing clamp method                                                                                                          |
| IEC 62153-4-15  | Metallic communication cable test methods - Part 4-15: Electromagnetic compatibility (EMC) - Test method for measuring transfer impedance and screening attenuation - or coupling attenuation with triaxial cell                                                                         |
| IEC 62236-1     | Railway applications - Electromagnetic compatibility - Part 1: General                                                                                                                                                                                                                   |
| IEC 62236-2     | Railway applications - Electromagnetic compatibility - Part 2: Emission of the whole railway system to the outside world                                                                                                                                                                 |
| IEC 62236-3-1   | Railway applications - Electromagnetic compatibility - Part 3-1: Rolling stock - Train and complete vehicle                                                                                                                                                                              |
| IEC 62236-3-2   | Railway applications - Electromagnetic compatibility - Part 3-2: Rolling stock - Apparatus                                                                                                                                                                                               |
| IEC 62236-4     | Railway applications - Electromagnetic compatibility - Part 4: Emission and immunity of the signalling and telecommunications apparatus                                                                                                                                                  |
| IEC 62236-5     | Railway applications - Electromagnetic compatibility - Part 5: Emission and immunity of fixed power supply installations and apparatus                                                                                                                                                   |
| IEC 62305-1     | Protection against lightning - Part 1: General principles                                                                                                                                                                                                                                |
| IEC 62305-2     | Protection against lightning - Part 2: Risk management                                                                                                                                                                                                                                   |
| IEC 62305-3     | Protection against lightning - Part 3: Physical damage to structures and life hazard                                                                                                                                                                                                     |



| IEC (continued) |                                                                                                                                                     |
|-----------------|-----------------------------------------------------------------------------------------------------------------------------------------------------|
| Document Number | Title                                                                                                                                               |
| IEC 62305-4     | Protection against lightning - Part 4: Electrical and electronic systems within structures                                                          |
| IEC 62310-2     | Static transfer systems (STS) - Part 2: Electromagnetic compatibility (EMC) requirements                                                            |
| IEC/TR 62482    | Electrical installations in ships - Electromagnetic compatibility - Optimising of cable installations on ships - Testing method of routing distance |

| CISPR           |                                                                                                                                                                                                                          |
|-----------------|--------------------------------------------------------------------------------------------------------------------------------------------------------------------------------------------------------------------------|
| Document Number | Title                                                                                                                                                                                                                    |
| CISPR 11        | Industrial, scientific and medical (ISM) radio-frequency equipment - Electromagnetic disturbance characteristics - Limits and methods of measurement                                                                     |
| CISPR 12        | Vehicles, boats and internal combustion engines - Radio disturbance characteristics - Limits and methods of measurement for the protection of off-board receivers                                                        |
| CISPR 13        | Sound and television broadcast receivers and associated equipment - Radio disturbance characteristics - Limits and methods of measurement                                                                                |
| CISPR 14-1      | Electromagnetic compatibility - Requirements for household appliances, electric tools and similar apparatus - Part 1: Emission                                                                                           |
| CISPR 14-2      | Electromagnetic compatibility - Requirements for household appliances, electric tools and similar apparatus - Part 2: Immunity - Product family standard                                                                 |
| CISPR 15        | Limits and methods of measurement of radio disturbance characteristics of electrical lighting and similar equipment                                                                                                      |
| CISPR 16-1-1    | Specification for radio disturbance and immunity measuring apparatus and methods - Part 1-1: Radio disturbance and immunity measuring apparatus - Measuring apparatus                                                    |
| CISPR 16-1-2    | Specification for radio disturbance and immunity measuring apparatus and methods - Part 1-2: Radio disturbance and immunity measuring apparatus - Coupling devices for conducted disturbance measurements                |
| CISPR 16-1-3    | Specification for radio disturbance and immunity measuring apparatus and methods - Part 1-3: Radio disturbance and immunity measuring apparatus - Ancillary equipment - Disturbance power                                |
| CISPR 16-1-4    | Specification for radio disturbance and immunity measuring apparatus and methods - Part 1-4: Radio disturbance and immunity measuring apparatus - Antennas and test sites for radiated disturbance measurements          |
| CISPR 16-1-5    | Specification for radio disturbance and immunity measuring apparatus and methods - Part 1-5: Radio disturbance and immunity measuring apparatus - Antenna calibration sites and reference test sites for 5 MHz to 18 GHz |
| CISPR 16-1-6    | Specification for radio disturbance and immunity measuring apparatus and methods - Part 1-6: Radio disturbance and immunity measuring apparatus - EMC antenna calibration                                                |
| CISPR 16-2-1    | Specification for radio disturbance and immunity measuring apparatus and methods - Part 2-1: Methods of measurement of disturbances and immunity - Conducted disturbance measurements                                    |
| CISPR 16-2-2    | Specification for radio disturbance and immunity measuring apparatus and methods - Part 2-2: Methods of measurement of disturbances and immunity - Measurement of disturbance power                                      |
| CISPR 16-2-3    | Specification for radio disturbance and immunity measuring apparatus and methods - Part 2-3: Methods of measurement of disturbances and immunity - Radiated disturbance measurements                                     |

| CISPR (continued) |                                                                                                                                                                                                                                                      |
|-------------------|------------------------------------------------------------------------------------------------------------------------------------------------------------------------------------------------------------------------------------------------------|
| Document Number   | Title                                                                                                                                                                                                                                                |
| CISPR 16-2-4      | Specification for radio disturbance and immunity measuring apparatus and methods - Part 2-4: Methods of measurement of disturbances and immunity - Immunity measurements                                                                             |
| CISPR TR 16-2-5   | Specification for radio disturbance and immunity measuring apparatus and methods - Part 2-5: In situ measurements for disturbing emissions produced by physically large equipment                                                                    |
| CISPR TR 16-3     | Specification for radio disturbance and immunity measuring apparatus and methods - Part 3: CISPR technical reports                                                                                                                                   |
| CISPR TR 16-4-1   | Specification for radio disturbance and immunity measuring apparatus and methods - Part 4-1: Uncertainties, statistics and limit modelling - Uncertainties in standardized EMC tests                                                                 |
| CISPR 16-4-2      | Specification for radio disturbance and immunity measuring apparatus and methods - Part 4-2: Uncertainties, statistics and limit modelling - Measurement instrumentation uncertainty                                                                 |
| CISPR TR 16-4-3   | Specification for radio disturbance and immunity measuring apparatus and methods - Part 4-3: Uncertainties, statistics and limit modelling - Statistical considerations in the determination of EMC compliance of mass-produced products             |
| CISPR TR 16-4-4   | Specification for radio disturbance and immunity measuring apparatus and methods - Part 4-4: Uncertainties, statistics and limit modelling - Statistics of complaints and a model for the calculation of limits for the protection of radio services |
| CISPR TR 16-4-5   | Specification for radio disturbance and immunity measuring apparatus and methods - Part 4-5: Uncertainties, statistics and limit modelling - Conditions for the use of alternative test methods                                                      |
| CISPR 17          | Methods of measurement of the suppression characteristics of passive EMC filtering devices                                                                                                                                                           |
| CISPR TR 18-1     | Radio interference characteristics of overhead power lines and high-voltage equipment - Part 1: Description of phenomena                                                                                                                             |
| CISPR TR 18-2     | Radio interference characteristics of overhead power lines and high-voltage equipment - Part 2: Methods of measurement and procedure for determining limits                                                                                          |
| CISPR TR 18-3     | Radio interference characteristics of overhead power lines and high-voltage equipment - Part 3: Code of practice for minimizing the generation of radio noise                                                                                        |
| CISPR 20          | Sound and television broadcast receivers and associated equipment - Immunity characteristics - Limits and methods of measurement                                                                                                                     |
| CISPR 22          | Information technology equipment - Radio disturbance characteristics - Limits and methods of measurement                                                                                                                                             |
| CISPR 24          | Information technology equipment - Immunity characteristics - Limits and methods of measurement                                                                                                                                                      |
| CISPR 25          | Vehicles, boats and internal combustion engines - Radio disturbance characteristics - Limits and methods of measurement for the protection of on-board receivers                                                                                     |
| CISPR 32          | Electromagnetic compatibility of multimedia equipment - Emission requirements                                                                                                                                                                        |
| CISPR 35          | Electromagnetic compatibility of multimedia equipment - Immunity requirements                                                                                                                                                                        |

# MILITARY RELATED DOCUMENTS & STANDARDS

The following references are not intended to be all inclusive, but rather a representation of available sources of additional information and point of contacts.

---

MIL-HDBK-235-1C Military Operational Electromagnetic Environment Profiles Part 1C General Guidance, 1 Oct 2010.

MIL-HDBK-237D Electromagnetic Environmental Effects and Spectrum Certification Guidance for the Acquisition Process, 20 May 2005.

MIL-HDBK-240A Hazards of Electromagnetic Radiation to Ordnance (HERO) Test Guide, 10 Mar 2011.

MIL-HDBK-263B Electrostatic Discharge Control Handbook for Protection of Electrical and Electronic Parts, Assemblies and Equipment (Excluding Electrically Initiated Explosive Devices), 31 Jul 1994.

MIL-HDBK-274A Electrical Grounding for Aircraft Safety, 14 Nov 2011.

MIL-HDBK-335 Management and Design Guidance Electromagnetic Radiation Hardness for Air Launched Ordnance Systems, Notice 4, 08 Jul 2008.

MIL-HDBK-419A Grounding, Bonding, and Shielding for Electronic Equipment and Facilities, 29 Dec 1987.

MIL-HDBK-454B General Guidelines for Electronic Equipment, 15 Apr 2007.

MIL-HDBK-1004-6 Lightning Protection, 30 May 1988.

MIL-HDBK-1195, Radio Frequency Shielded Enclosures, 30 Sep 1988.

MIL-HDBK-1512 Electroexplosive Subsystems, Electrically Initiated, Design Requirements and Test Methods, 30 Sep 1997.

MIL-HDBK-1857 Grounding, Bonding and Shielding Design Practices, 27 Mar 1998.

MIL-STD-188-124B Grounding, Bonding, and Shielding for Common Long Haul/Tactical Communications-Electronics Facilities and Equipment, 18 Dec 2000.

MIL-STD-188-125-1 High-Altitude Electromagnetic Pulse

(HEMP) Protection for Ground-Based C41 Facilities Performing Critical, Time-Urgent Missions Part 1 Fixed Facilities, 17 Jul 1998.

MIL-STD-220C Test Method Standard Method of Insertion Loss Measurement, 14 May 2009.

MIL-STD-331C Fuze and Fuze Components, Environmental and Performance Tests for, 22 Jun 2009.

MIL-STD-449D Radio Frequency Spectrum Characteristics, Measurement of, 22 Feb 1973.

MIL-STD-461F Requirements for the Control of Electromagnetic Interference Characteristics of Subsystems and Equipment, 10 Dec 2007.

MIL-STD-461G Requirements for the Control of Electromagnetic Interference Characteristics of Subsystems and Equipment, 11 Dec 2015.

MIL-STD-464C Electromagnetic Environmental Effects Requirements for Systems, 01 Dec 2010.

MIL-STD-704E Aircraft Electric Power Characteristics, 12 Mar 2004.

MIL-STD-1310H Standard Practice for Shipboard Bonding, Grounding, and Other Techniques for Electromagnetic Compatibility Electromagnetic Pulse (EMP) Mitigation and Safety, 17 Sep 2009.

MIL-STD-1377 Effectiveness of Cable, Connector, and Weapon Enclosure Shielding and Filters in Precluding Hazards of EM Radiation to Ordnance; Measurement of, 20 Aug 1971.

MIL-STD-1399 Section 300B Interface Standard for Shipboard Systems, Electric Power, Alternating Current, 24 Apr 2008.

MIL-STD-1541A Electromagnetic Compatibility Requirements for Space Systems, 30 Dec 1987.

MIL-STD-1542B Electromagnetic Compatibility and Grounding Requirements for Space System Facilities,



15 Nov 1991. MIL-STD-1605 Procedures for Conducting a Shipboard Electromagnetic Interference (EMI) Survey (Surface Ships), 08 Oct 2009.

MIL-STD-1686C Electrostatic Discharge Control Program for Protection of Electrical and Electronic Parts, Assemblies, and Equipment (Excluding Electrically Initiated Explosive Devices). 25 Oct 1995.

ADS-37A-PRF Electromagnetic Environmental Effects (E3) Performance and Verification Requirements, 28 May 1996.

DOD-STD-1399 Section 070 Part 1 D.C. Magnetic Field Environment, Notice 1, 30 Nov 1989.

DoDI 3222.03 DoD Electromagnetic Environmental Effects (E3) Program, 24 Aug 2014.

DoDD 4650.01 Policy and Procedures for Management and Use of the Electromagnetic Spectrum, 09 Jan 2009.

DoDI 6055.11 Protecting Personnel from Electromagnetic Fields, 19 Aug 2009.

---

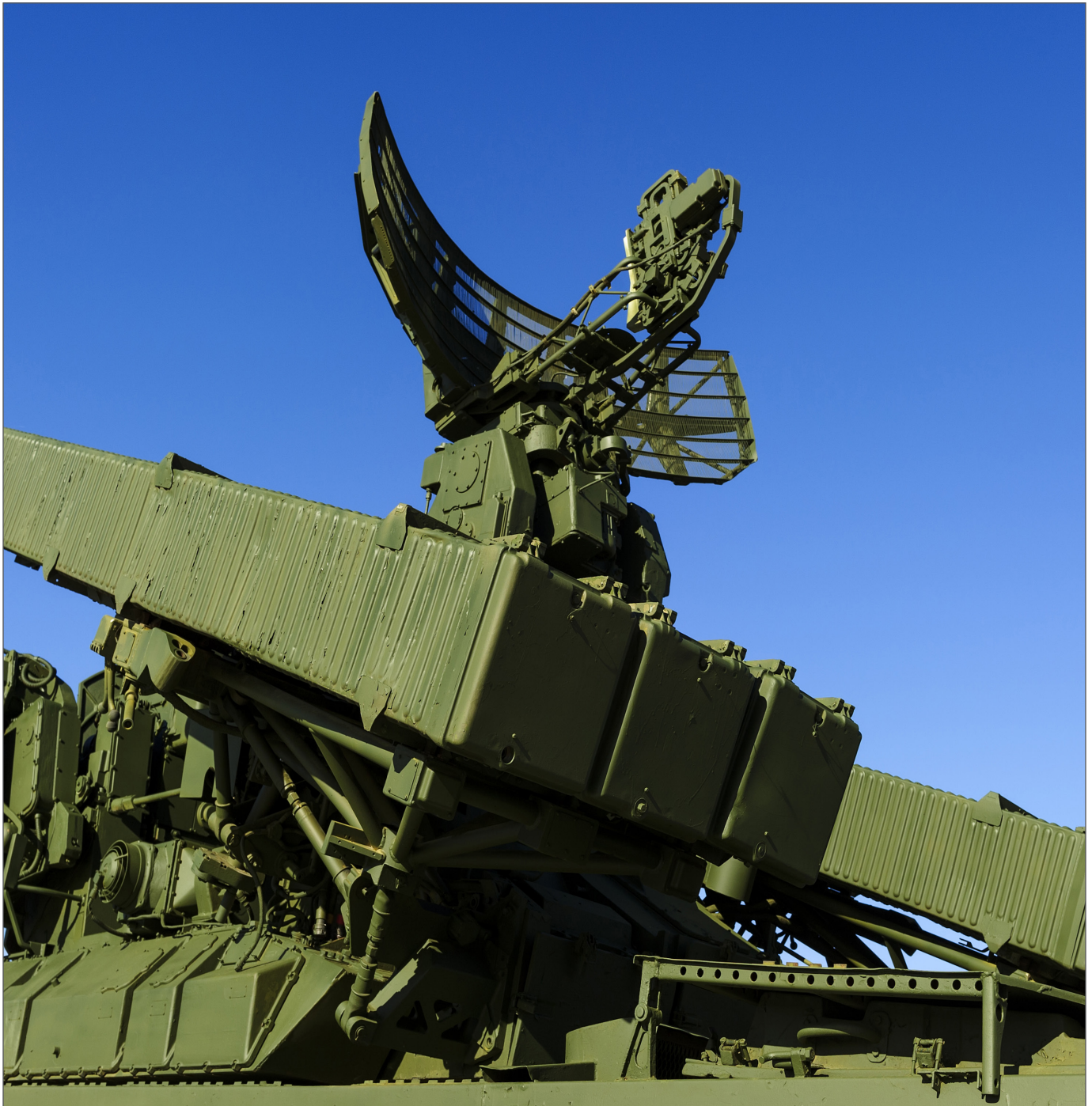

# AUTOMOTIVE ELECTROMAGNETIC COMPATIBILITY (EMC) STANDARDS

The following list of automotive EMC standards was developed by Dr. Todd Hubing, Professor Emeritus of Clemson University Vehicular Electronics Lab ([http://www.cvel.clemson.edu/auto/auto\\_emc\\_standards.html](http://www.cvel.clemson.edu/auto/auto_emc_standards.html)). A few of these standards have been made public and are linked below, but many others are considered company confidential and are only available to approved automotive vendors or test equipment manufacturers.

While several standards are linked on this list, an internet search may help locate additional documents that have been made public. Permission to republish has been approved.

| CISPR (Automotive Emissions Requirements) |                                                                                                                                                                                                                                                                       | ISO (Automotive Immunity Requirements) continued |                                                                                                                                                                                                        |
|-------------------------------------------|-----------------------------------------------------------------------------------------------------------------------------------------------------------------------------------------------------------------------------------------------------------------------|--------------------------------------------------|--------------------------------------------------------------------------------------------------------------------------------------------------------------------------------------------------------|
| Document Number                           | Title                                                                                                                                                                                                                                                                 | Document Number                                  | Title                                                                                                                                                                                                  |
| CISPR 12                                  | Vehicles, boats, and internal combustion engine driven devices – Radio disturbance characteristics – Limits and methods of measurement for the protection of receivers except those installed in the vehicle/boat/device itself or in adjacent vehicles/boats/devices | ISO 11451-2                                      | Road vehicles – Vehicle test methods for electrical disturbances from narrowband radiated electromagnetic energy – Part 2: Off-vehicle radiation sources                                               |
| CISPR 25                                  | Radio disturbance characteristics for the protection of receivers used on board vehicles, boats, and on devices – Limits and methods of measurement                                                                                                                   | ISO 11451-3                                      | Road vehicles – Electrical disturbances by narrowband radiated electromagnetic energy – Vehicle test methods – Part 3: On-board transmitter simulation                                                 |
| ISO (Automotive Immunity Requirements)    |                                                                                                                                                                                                                                                                       | ISO 11451-4                                      | Road vehicles – Vehicle test methods for electrical disturbances from narrowband radiated electromagnetic energy – Part 4: Bulk current injection (BCI)                                                |
| Document Number                           | Title                                                                                                                                                                                                                                                                 | ISO 11452-1                                      | Road vehicles – Component test methods for electrical disturbances from narrowband radiated electromagnetic energy – Part 1: General principles and terminology                                        |
| ISO 7637-1                                | Road vehicles – Electrical disturbances from conduction and coupling – Part 1: Definitions and general considerations                                                                                                                                                 | ISO 11452-2                                      | Road vehicles – Component test methods for electrical disturbances from narrowband radiated electromagnetic energy – Part 2: Absorber-lined shielded enclosure                                         |
| ISO 7637-2                                | Road vehicles – Electrical disturbances from conduction and coupling – Part 2: Electrical transient conduction along supply lines only                                                                                                                                | ISO 11452-3                                      | Road vehicles – Component test methods for electrical disturbances from narrowband radiated electromagnetic energy – Part 3: Transverse electromagnetic mode (TEM) cell                                |
| ISO 7637-3                                | Road vehicles – Electrical disturbance by conduction and coupling – Part 3: Vehicles with nominal 12 V or 24 V supply voltage – Electrical transient transmission by capacitive and inductive coupling via lines other than supply lines                              | ISO 11452-4                                      | Road vehicles – Component test methods for electrical disturbances from narrowband radiated electromagnetic energy – Part 4: Bulk current injection (BCI)                                              |
| ISO/TR 10305-1                            | Road vehicles – Calibration of electromagnetic field strength measuring devices – Part 1: Devices for measurement of electromagnetic fields at frequencies > 0 Hz                                                                                                     | ISO 11452-5                                      | Road vehicles – Component test methods for electrical disturbances from narrowband radiated electromagnetic energy – Part 5: Stripline                                                                 |
| ISO/TR 10305-2                            | Road vehicles – Calibration of electromagnetic field strength measuring devices – Part 2: IEEE standard for calibration of electromagnetic field sensors and probes, excluding antennas, from 9 kHz to 40 GHz                                                         | ISO 11452-7                                      | Road vehicles – Component test methods for electrical disturbances from narrowband radiated electromagnetic energy – Part 7: Direct radio frequency (RF) power injection                               |
| ISO 10605                                 | Road vehicles – Test methods for electrical disturbances from electrostatic discharge                                                                                                                                                                                 | ISO 11452-8                                      | Road vehicles – Component test methods for electrical disturbances from narrowband radiated electromagnetic energy – Part 8: Immunity to magnetic fields                                               |
| ISO/TS 14907-1                            | Road transport and traffic telematics – Electronic fee collection – Test procedures for user and fixed equipment – Part 1: Description of test procedures                                                                                                             | ISO 11452-10                                     | Road vehicles – Component test methods for electrical disturbances from narrowband radiated electromagnetic energy – Part 10: Immunity to conducted disturbances in the extended audio frequency range |
| ISO/TS 14907-2                            | Road transport and traffic telematics – Electronic fee collection – Test procedures for user and fixed equipment – Part 2: Conformance test for the onboard unit application interface                                                                                | ISO 11452-11                                     | Road vehicles – Component test methods for electrical disturbances from narrowband radiated electromagnetic energy – Part 11: Reverberation chamber                                                    |
| ISO/TS 21609                              | Road vehicles – (EMC) guidelines for installation of aftermarket radio frequency transmitting equipment                                                                                                                                                               | ISO 13766                                        | Earth-moving machinery – Electromagnetic compatibility                                                                                                                                                 |
| ISO 11451-1                               | Road vehicles – Vehicle test methods for electrical disturbances from narrowband radiated electromagnetic energy – Part 1: General principles and terminology                                                                                                         |                                                  |                                                                                                                                                                                                        |



| SAE (Automotive Emissions and Immunity) |                                                                                                                                                                     |
|-----------------------------------------|---------------------------------------------------------------------------------------------------------------------------------------------------------------------|
| Document Number                         | Title                                                                                                                                                               |
| J1113/1                                 | Electromagnetic Compatibility Measurement Procedures and Limits for Components of Vehicles, Boats (Up to 15 M), and Machines (Except Aircraft) (50 Hz to 18 GHz)    |
| J1113/2                                 | Electromagnetic Compatibility Measurement Procedures and Limits for Vehicle Components (Except Aircraft)-Conducted Immunity, 15 Hz to 250 kHz-All Leads             |
| J1113/3                                 | Conducted Immunity, 250 kHz to 400 MHz, Direct Injection of Radio Frequency (RF) Power (Cancelled August 2010)                                                      |
| J1113/4                                 | Immunity to Radiated Electromagnetic Fields-Bulk Current Injection (BCI) Method                                                                                     |
| J1113/11                                | Immunity to Conducted Transients on Power Leads                                                                                                                     |
| J1113/12                                | Electrical Interference by Conduction and Coupling - Capacitive and Inductive Coupling via Lines Other than Supply Lines                                            |
| J1113/13                                | Electromagnetic Compatibility Measurement Procedure for Vehicle Components - Part 13: Immunity to Electrostatic Discharge                                           |
| J1113/21                                | Electromagnetic Compatibility Measurement Procedure for Vehicle Components - Part 21: Immunity to Electromagnetic Fields, 30 MHz to 18 GHz, Absorber-Lined Chamber  |
| J1113/24                                | Immunity to Radiated Electromagnetic Fields; 10 kHz to 200 MHz-Crawford TEM Cell and 10 kHz to 5 GHz-Wideband TEM Cell (Cancelled August 2010)                      |
| J1113/26                                | Electromagnetic Compatibility Measurement Procedure for Vehicle Components - Immunity to AC Power Line Electric Fields                                              |
| J1113/27                                | Electromagnetic Compatibility Measurements Procedure for Vehicle Components - Part 27: Immunity to Radiated Electromagnetic Fields - Mode Stir Reverberation Method |
| J1113/28                                | Electromagnetic Compatibility Measurements Procedure for Vehicle Components-Part 28-Immunity to Radiated Electromagnetic Fields-Reverberation Method (Mode Tuning)  |
| J1113/42                                | Electromagnetic Compatibility-Component Test Procedure-Part 42-Conducted Transient Emissions (Cancelled Dec 2010, Superseded by ISO 7637-2)                         |
| J1752/1                                 | Electromagnetic Compatibility Measurement Procedures for Integrated Circuits-Integrated Circuit EMC Measurement Procedures-General and Definition                   |
| J1752/2                                 | Measurement of Radiated Emissions from Integrated Circuits - Surface Scan Method (Loop Probe Method) 10 MHz to 3 GHz                                                |
| J1752/3                                 | Measurement of Radiated Emissions from Integrated Circuits - TEM/Wideband TEM (GTEM) Cell Method; TEM Cell (150 kHz to 1 GHz), Wideband TEM Cell (150 kHz to 8 GHz) |
| J551/5                                  | Performance Levels and Methods of Measurement of Magnetic and Electric Field Strength from Electric Vehicles, Broadband, 9 kHz To 30 MHz                            |
| J551/11                                 | Vehicle Electromagnetic Immunity-Off-Vehicle Source (Cancelled March 2010)                                                                                          |

| SAE (Automotive Emissions and Immunity) continued |                                                                                                                                                                                                                                                 |
|---------------------------------------------------|-------------------------------------------------------------------------------------------------------------------------------------------------------------------------------------------------------------------------------------------------|
| Document Number                                   | Title                                                                                                                                                                                                                                           |
| J551/12                                           | Vehicle Electromagnetic Immunity-On-Board Transmitter Simulation (Cancelled August 2009)                                                                                                                                                        |
| J551/13                                           | Vehicle Electromagnetic Immunity-Bulk Current Injection (Cancelled August 2009)                                                                                                                                                                 |
| J551/15                                           | Vehicle Electromagnetic Immunity-Electrostatic Discharge (ESD)                                                                                                                                                                                  |
| J551/16                                           | Electromagnetic Immunity - Off-Vehicle Source (Reverberation Chamber Method) - Part 16 - Immunity to Radiated Electromagnetic Fields                                                                                                            |
| J551/17                                           | Vehicle Electromagnetic Immunity - Power Line Magnetic Fields                                                                                                                                                                                   |
| J1812                                             | Function Performance Status Classification for EMC Immunity Testing                                                                                                                                                                             |
| J2628                                             | Characterization-Conducted Immunity                                                                                                                                                                                                             |
| J2556                                             | Radiated Emissions (RE) Narrowband Data Analysis-Power Spectral Density (PSD)                                                                                                                                                                   |
| GM                                                |                                                                                                                                                                                                                                                 |
| Document Number                                   | Title                                                                                                                                                                                                                                           |
| GMW3091                                           | General Specification for Vehicles, Electromagnetic Compatibility (EMC)-Engl; Revision H; Supersedes GMI 12559 R and GMI 12559 V                                                                                                                |
| GMW3097                                           | General Specification for Electrical/Electronic Components and Subsystems, Electromagnetic Compatibility-Engl; Revision H; Supersedes GMW12559, GMW3100, GMW12002R AND GMW12002V                                                                |
| GMW3103                                           | General Specification for Electrical/Electronic Components and Subsystems, Electromagnetic Compatibility Global EMC Component/Subsystem Validation Acceptance Process-Engl; Revision F; Contains Color; Replaces GMW12003, GMW12004 and GMW3106 |
| Ford                                              |                                                                                                                                                                                                                                                 |
| Document Number                                   | Title                                                                                                                                                                                                                                           |
| EMC-CS-2009.1                                     | Component EMC Specification EMC-CS-2009.1                                                                                                                                                                                                       |
| FORD F-2                                          | Electrical and Electronics System Engineering                                                                                                                                                                                                   |
| FORD WSF-M22P5-A1                                 | Printed Circuit Boards, PTF, Double Sided, Flexible                                                                                                                                                                                             |
| DaimlerChrysler                                   |                                                                                                                                                                                                                                                 |
| Document Number                                   | Title                                                                                                                                                                                                                                           |
| DC-10614                                          | EMC Performance Requirements - Components                                                                                                                                                                                                       |
| DC-10615                                          | Electrical System Performance Requirements for Electrical and Electronic Components                                                                                                                                                             |
| DC-11224                                          | EMC Performance Requirements - Components                                                                                                                                                                                                       |
| DC-11225                                          | EMC Supplemental Information and Alternative Component Requirements                                                                                                                                                                             |
| DC-11223                                          | EMC Performance Requirements - Vehicle                                                                                                                                                                                                          |

| Other Automotive Manufacturers |                                                                               |
|--------------------------------|-------------------------------------------------------------------------------|
| Audi TL 82466                  | Electrostatic Discharge                                                       |
| BMW 600 13.0                   | Electric- / Electronic components in cars                                     |
| BMW GS 95002                   | Electromagnetic Compatibility (EMC) Requirements and Tests                    |
| BMW GS 95003-2                 | Electric- / Electronic assemblies in motor vehicles                           |
| Chrysler PF 9326               | Electrical electronic modules and motors                                      |
| FIAT 9.90110                   | Electric and electronic devices for motor vehicles                            |
| Freightliner 49-00085          | EMC Requirements                                                              |
| Honda 3838Z-SSAA-L000          | Noise Simulation Test                                                         |
| Honda 3982Z-SDA-0030           | Battery Simulation Test                                                       |
| Hyundai/Kia ES 39110-00        | EMC Requirements                                                              |
| Hyundai/Kia ES-95400-10        | Battery Simulation Tests                                                      |
| Hyundai/Kia ES 96100-01        | EMC Requirements                                                              |
| IVECO 16-2103                  | EMC Requirements                                                              |
| Lotus 17.39.01                 | Lotus Engineering Standard: Electromagnetic Compatibility                     |
| Mack Trucks 606GS15            | EMC Requirements                                                              |
| MAN 3285                       | EMC Requirements                                                              |
| Mazda MES PW 67600             | Automobile parts standard (electronic devices)                                |
| Mercedes A 211 000 42 99       | Instruction specification of test method for E/E-components                   |
| Mercedes AV EMV                | Electric aggregate and electronics in cars                                    |
| Mercedes MBN 10284-2           | EMC requirements and tests of E/E-systems (component test procedures)         |
| Mercedes MBN 22100-2           | Electric / electronic elements, devices in trucks                             |
| Mitsubishi ES-X82010           | General specification of environment tests on automotive electronic equipment |
| Nissan 28401 NDS02             | EMC requirements (instruction concerning vehicle and electrical ...)          |
| Nissan 28400 NDS03             | Low frequency surge resistance of electronic parts                            |
| Nissan 28400 NDS04             | Burst and Impulse Waveforms                                                   |
| Nissan 28400 NDS07             | Immunity against low frequency surge (induction surge) of electronic parts    |
| Peugeot B217110                | Load Dump Pulses                                                              |
| Porsche AV EMC EN              | EMC Requirements                                                              |
| PSA B21 7090                   | EMC Requirements (electric and electronics equipment)                         |
| PSA B21 7110                   | EMC requirements (electric and electronics equipment)                         |
| Renault 36.00.400              | Physical environment of electrical and electronic equipments                  |
| Renault 36.00.808              | EMC requirements (cars and electrical / electronic components)                |
| Scania TB1400                  | EMC Requirements                                                              |
| Scania TB1700                  | Load Dump Test                                                                |

| Other Automotive Manufacturers |                                                                                                       |
|--------------------------------|-------------------------------------------------------------------------------------------------------|
| Smart DE10005B                 | EMC requirements (electric aggregate and electronics in cars)                                         |
| Toyota TSC7001G                | Engineering standard (electric noise of electronic devices)                                           |
| Toyota TSC7001G-5.1            | Power Supply Voltage Characteristic Test                                                              |
| Toyota TSC7001G-5.2            | Field Decay Test                                                                                      |
| Toyota TSC7001G-5.3            | Floating Ground Test                                                                                  |
| Toyota TSC7001G-5.4            | Induction Noise Resistance                                                                            |
| Toyota TSC7001G-5.5.3          | Load Dump Test-1                                                                                      |
| Toyota TSC7001G-5.5.4          | Load Dump Test-2                                                                                      |
| Toyota TSC7001G-5.5.5          | Load Dump Test-3                                                                                      |
| Toyota TSC7001G-5.6            | Over Voltage Test                                                                                     |
| Toyota TSC7001G-5.7.3          | Ignition Pulse (Battery Waveforms) Test-1                                                             |
| Toyota TSC7001G-5.7.4          | Ignition Pulse (Battery Waveforms) Test-2                                                             |
| Toyota TSC7001G-5.8            | Reverse Voltage                                                                                       |
| Toyota TSC7006G-4.4.2          | Wide Band-Width Antenna Nearby Test (0.4 to 2 GHz)                                                    |
| Toyota TSC7006G-4.4.3          | Radio Equipment Antenna nearby Test (28 MHz ...)                                                      |
| Toyota TSC7006G-4.4.4          | Mobile Phone Antenna Nearby Test (835 MHz ...)                                                        |
| Toyota TSC7018G                | Static Electricity Test                                                                               |
| Toyota TSC7025G-5              | TEM Cell Test (1 to 400 MHz)                                                                          |
| Toyota TSC7025G-6              | Free Field Immunity Test (20 MHz to 1 GHz AM, 0.8 to 2 GHz PM)                                        |
| Toyota TSC7025G-7              | Strip Line Test (20 - 400 MHz)                                                                        |
| Toyota TSC7026G-3.4            | Narrow Band Emissions                                                                                 |
| Toyota TSC7203G                | Voltage Drop / Micro Drops                                                                            |
| Toyota TSC7508G-3.3.1          | Conductive Noise in FM and TV Bands                                                                   |
| Toyota TSC7508G-3.3.2          | Conductive noise in LW, AM and SW Bands                                                               |
| Toyota TSC7508G-3.3.3          | Radiated Noise in FM and TV Bands                                                                     |
| Toyota TSC7508G-3.3.4          | Radiated Noise in AM, SW, and LW Bands                                                                |
| Toyota TSC7203G                | Engineering standard (ABS-TRC computers)                                                              |
| Toyota TXC7315G                | Electrostatic Discharge (Gap Method)                                                                  |
| Visteon ES-XU3F-1316-AA        | Electronic Component - Subsystem Electromagnetic Compatibility (EMC) Requirements and Test Procedures |
| Volvo EMC Requirements         | EMC requirements for 12V and 24V systems                                                              |
| Volkswagen VW TL 801 01        | Electric and electronic components in cars                                                            |
| Volkswagen VW TL 820 66        | Conducted Interference                                                                                |
| Volkswagen VW TL 821 66        | EMC requirements of electronic components - bulk current injection (BCI)                              |
| Volkswagen VW TL 823 66        | Coupled Interference on Sensor Cables                                                                 |
| Volkswagen VW TL 824 66        | Immunity Against Electrostatic Discharge                                                              |
| Volkswagen VW TL 965           | Short-Distance Interference Suppression                                                               |



# USEFUL EMC TESTING REFERENCES

(DIRECTORY, BOOKS, ORGANIZATIONS, LINKEDIN GROUPS)

---

## RECOMMENDED BOOKS, MAGAZINES, & JOURNALS

### 2018 EMC Directory & Design Guide

(includes a worldwide listing of commercial test labs)  
<https://learn.interferencetechnology.com/2018-directory-design-guide/>

## RECOMMENDED BOOKS

### André and Wyatt

EMI Troubleshooting Cookbook for Product Designers  
SciTech Publishing, 2014.

Includes chapters on product design and EMC theory & measurement. A major part of the content includes how to troubleshoot and mitigate all common commercial EMC test failures.

### Archambeault

PCB Design for Real-World EMI Control  
Kluwer Academic Publishers, 2002.

### Bogatin

Signal & Power Integrity - Simplified  
Prentice-Hall, 2018 (3rd Edition).

Great coverage of signal and power integrity from a fields viewpoint.

### Hall, Hall, and McCall

High-Speed Digital System Design - A Handbook of Interconnect Theory and Design Practices  
Wiley, 2000.

### Joffe and Lock

Grounds For Grounding  
Wiley, 2010.

This huge book includes way more topics on product design than the title suggests. Covers all aspects of grounding and shielding for products, systems, and facilities.

### Johnson and Graham

High-Speed Digital Design - A Handbook of Black Magic  
Prentice-Hall, 1993.

Practical coverage of high speed digital signals and measurement.

### Johnson and Graham

High-Speed Signal Propagation - Advanced Black Magic  
Prentice-Hall, 2003.

Practical coverage of high speed digital signals and measurement.

### Kimmel and Gerke

Electromagnetic Compatibility in Medical Equipment  
IEEE Press, 1995.

Good general product design information.

### Mardiguian

EMI Troubleshooting Techniques  
McGraw-Hill, 2000.

Good coverage of EMI troubleshooting.

### Mardiguian

Controlling Radiated Emissions by Design  
Springer, 2016.

Good content on product design for compliance.

### Montrose

EMC Made Simple

Montrose Compliance Services, 2014.

The content includes several important areas of EMC theory and product design, troubleshooting, and measurement.

### Morrison

Digital Circuit Boards - Mach 1 GHz  
Wiley, 2012.

Important concepts of designing high frequency circuit boards from a fields viewpoint.

### Morrison

Grounding And Shielding - Circuits and Interference  
Wiley, 2016 (6th Edition).

The classic text on grounding and shielding with up to date content on how RF energy flows through circuit boards.

### Morrison

Fast Circuit Boards  
Wiley, 2018.

Morrison explains how signals propagate via transmission lines and why it's so important to include reference planes for every signal layer.

### Ott

Electromagnetic Compatibility Engineering  
Wiley, 2009.

The "bible" on EMC measurement, theory, and product design.

# USEFUL EMC TESTING REFERENCES (CONTINUED)

## (DIRECTORY, BOOKS, ORGANIZATIONS, LINKEDIN GROUPS)

---

### RECOMMENDED BOOKS (CONTINUED)

**Paul**

Introduction to Electromagnetic Compatibility  
Wiley, 2006 (2nd Edition).

The one source to go to for an upper-level course on EMC theory.

**Sandler**

Power Integrity - Measuring, Optimizing, and Troubleshooting Power Related Parameters in Electronics Systems  
McGraw-Hill, 2014.

The latest information on measurement and design of power distribution networks and how the network affects stability and EMC.

**Smith and Bogatin**

Principles of Power Integrity for PDN Design - Simplified  
Prentice-Hall, 2017.

Getting the power distribution network (PDN) design right is the key to reducing EMI.

**Williams**

EMC For Product Designers  
Newnes, 2017.

Completely updated text on product design for EMC compliance.

**Weston**

Electromagnetic Compatibility - Methods, Analysis, Circuits, and Measurement  
CRC Press, 2017 (3rd Edition).

A comprehensive text, primarily focused on military EMC.

**Wyatt**

EMC Desk Reference  
Interference Technology, 2017.

A handy guide with technical articles and pertinent EMC reference information.

**Wyatt & Jost**

Electromagnetic Compatibility (EMC) Pocket Guide  
SciTech Publishing, 2013.

A handy pocket-sized reference guide to EMC.

### EMC STANDARDS ORGANIZATION

**ANSI**

<http://www.ansi.org>

**ANSI Accredited C63**

<http://c63.org/index.htm>

**IEEE Standards Association**

<http://standards.ieee.org>

**SAE**

<http://www.sae.org>

**SAE EMC Standards Committee**

<http://www.sae.org/standards/>

**IEC**

<http://iec.ch>

**CISPR**

[http://www.iec.ch/emc/iec\\_emc/iec\\_emc\\_players\\_cispr.htm](http://www.iec.ch/emc/iec_emc/iec_emc_players_cispr.htm)

**ETSI**

<http://www.etsi.org>

### LINKEDIN GROUPS

EMC Experts

EMC Testing and Compliance

Electromagnetic Compatibility Forum

ESD Experts

EMC Troubleshooters



# EMC & DESIGN CONFERENCES 2018-2019

The following is a partial listing of major EMC and electronics design conferences planned for 2018 to 2019 in order of date. If your conference is not listed, please contact: [info@interferencetechnology.com](mailto:info@interferencetechnology.com)

---

## **International Symposium and Exhibition on Electromagnetic Compatibility (EMC Europe 2018)**

August 27 to 30, 2018  
Amsterdam, Netherlands  
[www.emceurope2018.org](http://www.emceurope2018.org)

The Organizers of leading International Symposium on Electromagnetic Compatibility in Europe are very pleased to invite and encourage all those working in the area of electromagnetic compatibility to Amsterdam to participate this prestigious event.

## **European Microwave Week 2018**

September 23 to 28, 2018  
Madrid, Spain  
[www.eumweek.com](http://www.eumweek.com)

The European Microwave Association (EuMA) is an international non-profit association with a scientific, educational and technical purpose. The aim of the Association is to develop in an interdisciplinary way, education, training and research activities.

## **Automotive Test Expo**

October 23 to 25, 2018  
Novi, MI  
[www.testing-expo.com/usa/](http://www.testing-expo.com/usa/)

This conference includes the very latest technologies and services that are designed to ensure that the highest standards are met in terms of product quality, reliability, durability and safety for the automotive industry.

## **Applied Power Electronics (APEC)**

March 17 to 21, 2019  
Anaheim, California  
[www.apec-conf.org](http://www.apec-conf.org)

APEC focuses on the practical and applied aspects of the power electronics business. This is not just a designer's conference; APEC has something of interest for anyone involved in power electronics:

- Equipment OEMs that use power supplies and dc-dc converters in their equipment
- Designers of power supplies, dc-dc converters, motor drives, uninterruptable power supplies, inverters and any other power electronic circuits, equipment and systems

- Compliance engineers testing and qualifying power electronics equipment or equipment that uses power electronics.

## **International Exhibition and Conference on Electromagnetic Compatibility EMC (EMV 2019)**

March 19 to 21, 2019  
Stuttgart, Germany  
<https://emv.mesago.com/events/en.html>

EMV is Europe's leading event on electromagnetic compatibility. Meet the industry's leading companies for EMC-equipment, components and EMC-services. The event offers a wide range of EMC-specific topics. The perfect platform to get the latest information on newest trends and developments!

## **Automotive Test Expo (includes EMC)**

May 21 to 23, 2019  
Stuttgart, Germany  
[www.testing-expo.com/europe/en/](http://www.testing-expo.com/europe/en/)

The event is the world's largest vehicle and component testing and validation technology and services exhibition, featuring more than 400 exhibitors and attracting over 9,000 attendees.

## **The 2019 Symposium on EMC+SIPI**

July 19 to 26, 2019  
New Orleans, Louisiana  
[www.emc2018usa.emcss.org](http://www.emc2018usa.emcss.org)

The Symposium on EMC+SIPI is the leading event to provide education of EMC and Signal and Power Integrity techniques to specialty engineers. The Symposium features five full days of innovative sessions, interactive workshops, tutorials, experiments, demonstrations, and social networking events.

# INDEX OF ADVERTISERS



**A.H. Systems, Inc.**  
9710 Cozycroft Ave,  
Chatsworth, CA 91311

**page:** 13  
**t:** (818) 998-0223  
**e:** sales@ahsystems.com  
**w:** www.ahsystems.com



**AR RF/Microwave Instrumentation**  
160 School House Rd.  
Souderton PA 18964-9990

**page:** 5  
**t:** (215) 723-8181  
**e:** info@arworld.us  
**w:** www.arworld.us



**EDICON 2018**  
Santa Clara Convention Center,  
Santa Clara, CA  
October 17-18, 2018

**page:** 25  
**t:** (781) 619-1930  
**e:** EDICONregistration@horizonhouse.com  
**w:** www.ediconusa.com



**MiCOM Labs**  
575 Boulder Court  
Pleasanton, CA 94566

**page:** 19  
**t:** (925) 462-0304  
**e:** sales@micomlabs.com  
**w:** www.micomlabs.com



**R&B Laboratories**  
20 Clipper Road  
West Conshohocken, PA 19428

**page:** 8  
**t:** (610) 825-1960  
**e:** rvohra@rblaboratory.com  
**w:** www.rblaboratory.com



**Rhode & Schwarz**  
Muehldorfstrasse 15  
81671 Munich, Germany

**page:** 2  
**t:** Germany: +49 (0) 89 4129 12345  
United States: (410) 910-7800  
**e:** email address  
**w:** www.rohde-schwarz.com  
www.rohde-schwarz-usa.com



**ITEM Media**  
1000 Germantown Pike  
Plymouth Meeting, PA 19462

**page:** 37  
**t:** (484) 688-0300  
**e:** info@item.media  
**w:** item.media



**EMC Live Bootcamp 2018**  
Online Event  
November 14, 2018

**page:** 29  
**t:** (484) 688-0300  
**e:** info@interferencetechnology.com  
**w:** www.emc.live



**EMC+SIPI Symposium**  
2018 IEEE Symposium on Electromagnetic  
Compatibility, Signal and Power Integrity  
Long Beach, CA & Online

**page:** 33  
**w:** www.emc2018usa.emcss.org





# 2018 EMC TESTING GUIDE

