

PRESENTED BY

**interference**  
technology®

**2016 MILITARY  
EMC GUIDE**



# Table of Contents

<b><i>SUPPLIER GUIDE: Table of New Equipment Allowed/Required in MIL-STD-461G</i></b> TONY KEYS EMC Analytical Services <b>KEN JAVOR</b> EMC Compliance	<b>3</b>
<hr/>	
<b>Introduction to DoD Policy, Guidance, and the Acquisition Process</b> TONY KEYS EMC Analytical Services <b>BRIAN FARMER</b> EMC Management Concepts	<b>10</b>
<b>Spectrum Management and the EME</b> TONY KEYS EMC Analytical Services <b>BRIAN FARMER</b> EMC Management Concepts	<b>15</b>
<b>Introduction to MIL-STD-464C</b> TONY KEYS EMC Analytical Services	<b>20</b>
<b>Introduction to MIL-STD-461G</b> TONY KEYS EMC Analytical Services <b>KEN JAVOR</b> EMC Compliance	<b>36</b>
<b>Military Related E3 Documents and POCs</b> TONY KEYS EMC Analytical Services	<b>54</b>



# Table of New Equipment Allowed/Required in MIL-STD-461G

---

## TONY KEYS

EMC Analytical Services

## KEN JAVOR

EMC Compliance

The following table was compiled by Ken Javor, of EMC Compliance. The updated changes to MIL-STD-461G require some new equipment. One of these changes allows the use of time domain EMI receivers, which will help speed up the testing, due to their fast FFT-based signal acquisition. Following is a list of some specific changes and equipment requirements:

**CS101** (Conducted Susceptibility, Power Leads) - There is now a requirement to measure induced AC power line ripple. This requires a new "power ripple detector", which is a specially designed isolation transformer that matches the power line to 50 Ohms.

**CS114** (Conducted Susceptibility, Bulk Cable Injection) - This injection probe test now requires the use of a current probe calibration fixture to validate the test level during pre-calibration.

**CS117** (Conducted Susceptibility, Lightning Induced Transients, Cables and Power Leads) - This is a new test added to MIL-STD-461G and requires a lightning transient simulator.

**CS118** (Conducted Susceptibility, Personnel Borne Electrostatic Discharge) - This is a new test added to MIL-STD-461G and requires a standard electrostatic discharge simulator.

**RS103** (Radiated Susceptibility, Electric Field) - This test requires an E-field antenna that can go down to 2 MHz.



# WHO SAYS YOU CAN'T HAVE IT ALL?

and with next-day, on-time Delivery

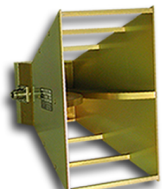

**DRG Horns**  
170 MHz - 40 GHz  
6 Models



**Log Periodics**  
80 MHz - 7 GHz  
13 Models



**Preamplifiers**  
20 MHz - 40 GHz  
8 Models

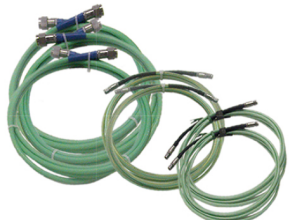

**Low Loss Cables**  
DC - 40 GHz  
4 Models



**Biconicals**  
20 MHz - 330 MHz  
5 Models



**All in one small package**



**H-Field Rods**  
100 Hz - 30 MHz  
4 Models



**BiLogicals**  
25 MHz - 7 MHz  
8 Models



**Probes**  
20 Hz - 1 GHz  
16 Models



**Standard Gain Horns**  
1 GHz - 40 GHz  
9 Models



**Loops**  
20 Hz - 30 MHz  
7 Models



**Tripods and Accessories**



**Monopoles**  
100 Hz - 60 MHz  
5 Models

**You Can Have It All** when it comes to EMC/EMI testing. A.H. Systems manufactures a complete line of affordable, reliable, individually calibrated EMC Test Antennas, Preamplifiers, Current Probes and Low-Loss, High - Frequency Cables that satisfy FCC, MIL-STD, VDE, IEC and SAE testing standards. We also provide tripods and accessories that compliment other EMC testing equipment used to complete your testing requirements. We provide rental programs for our equipment and offer recalibration services for Antennas, Preamplifiers, Current Probes and Cables, including other manufacturers worldwide. A.H. Systems provides next-day, on-time delivery for a fast turn around schedule to help minimize any down time the customer may be experiencing during testing. Manufacturing high quality products at competitive prices with immediate shipment plus prompt technical support are goals we strive to achieve at A.H. Systems. **Contact us at [sales@ahsystems.com](mailto:sales@ahsystems.com)**

**Antennas...**

**And Kits too.**



**Innovation Quality Performance**  
Phone: (818)998-0223 ♦ Fax (818)998-6892  
<http://www.AHSystems.com>

**A.H. Systems**



**Table of New Equipment Required for Latest Updates to MIL-STD-461G**

Requirement	Equipment Type	Vendor(s)	Websites
General	Time Domain EMI receivers*	Amplifier Research Gauss Instruments Keysight Rohde & Schwarz	<a href="http://www.arworld.us/html/dsp-receiver-multistar.asp">http://www.arworld.us/html/dsp-receiver-multistar.asp</a> <a href="http://www.gauss-instruments.com/en/products/tdemi">http://www.gauss-instruments.com/en/products/tdemi</a> <a href="http://www.keysight.com/en/pdx-x201870-pn-N9038A/mxe-emi-receiver-3-hz-to-44-ghz?cc=UG&amp;lc=eng">http://www.keysight.com/en/pdx-x201870-pn-N9038A/mxe-emi-receiver-3-hz-to-44-ghz?cc=UG&amp;lc=eng</a> <a href="https://www.rohde-schwarz.com/us/products/test-measurement/emc-field-strength-test-solutions/emc-field-strength-test-solutions_105344.html">https://www.rohde-schwarz.com/us/products/test-measurement/emc-field-strength-test-solutions/emc-field-strength-test-solutions_105344.html</a>
CS101	Frequency domain ripple monitoring transducer*  High-voltage differential probe, 100 MHz, 1k V(RMS)  Digital Oscilloscopes (200 MHz - 4 GHZ, 5/10 GSa/s)	Pearson Electronics  Rohde & Schwarz  Rohde & Schwarz	<a href="http://www.pearsonelectronics.com/news/179">http://www.pearsonelectronics.com/news/179</a>  <a href="https://www.rohde-schwarz.com/us/product/rtzd01-productstartpage_63493-34629.html">https://www.rohde-schwarz.com/us/product/rtzd01-productstartpage_63493-34629.html</a>  <a href="https://www.rohde-schwarz.com/us/product/rto-productstartpage_63493-10790.html">https://www.rohde-schwarz.com/us/product/rto-productstartpage_63493-10790.html</a> or <a href="https://www.rohde-schwarz.com/vn/product/rte-productstartpage_63493-54848.html">https://www.rohde-schwarz.com/vn/product/rte-productstartpage_63493-54848.html</a> with Option RTO-K17
CS114	Current probe calibration fixture	ETS/Lindgren  Fischer Custom Communications  Pearson Electronics  Solar Electronics	<a href="http://www.ets-lindgren.com/EMC">http://www.ets-lindgren.com/EMC</a> (fixture not listed on web site but should be part of current probe/injection clamp line-up)  <a href="http://www.fischercc.com/ViewProductGroup.aspx?productgroupid=141">http://www.fischercc.com/ViewProductGroup.aspx?productgroupid=141</a>  <a href="http://www.pearsonelectronics.com/news/180">http://www.pearsonelectronics.com/news/180</a> (fixture holds both injection clamp and current probe)  <a href="http://www.solar-emc.com/RFI-EMI.html">http://www.solar-emc.com/RFI-EMI.html</a> (scroll to bottom of page)
CS117	Indirect lightning test systems	HV Technologies  Thermo Scientific  Solar Electronics	<a href="http://www.hvtechnologies.com/TestsTrack/Lightning/tabid/408/Default">http://www.hvtechnologies.com/TestsTrack/Lightning/tabid/408/Default</a>  <a href="http://www.thermoscientific.com/en/product/ecat-lightning-test-system-lts.html">http://www.thermoscientific.com/en/product/ecat-lightning-test-system-lts.html</a>  <a href="http://www.solar-emc.com/2654-2.html">http://www.solar-emc.com/2654-2.html</a>
CS118	ESD gun	EMC Partner  EM Test  Haefely  Kikusui  LISUN Group  Noiseken  Thermo Scientific  TESEQ	<a href="https://www.emc-partner.com/products/immunity/esd/esd-generator">https://www.emc-partner.com/products/immunity/esd/esd-generator</a>  <a href="http://www.emtest.com/products/productGroups/ESD_generators.php">http://www.emtest.com/products/productGroups/ESD_generators.php</a>  <a href="http://www.haefely-hipotronics.com/product/product-category/electrostatic-discharge-test-systems-esd/">http://www.haefely-hipotronics.com/product/product-category/electrostatic-discharge-test-systems-esd/</a>  <a href="http://www.kikusui.co.jp/en/product/detail.php?ldFamily=0020">http://www.kikusui.co.jp/en/product/detail.php?ldFamily=0020</a>  <a href="http://www.lisungroup.com/product-id-318.html">http://www.lisungroup.com/product-id-318.html</a>  <a href="http://www.noiseken.com/modules/products/index.php?cat_id=1">http://www.noiseken.com/modules/products/index.php?cat_id=1</a>  <a href="http://www.thermoscientific.com/en/product/minizap-15-esd-simulator.html">http://www.thermoscientific.com/en/product/minizap-15-esd-simulator.html</a>  <a href="http://www.teseq.com/product-categories/esd-simulators.php">http://www.teseq.com/product-categories/esd-simulators.php</a>
RS103	1 – 18 GHz electric field probe (most test facilities already have one)	Amplifier Research  ETS/Lindgren  NARDA	<a href="http://www.arworld.us/html/field-analyzers-field-monitoring.asp">http://www.arworld.us/html/field-analyzers-field-monitoring.asp</a>  <a href="http://www.ets-lindgren.com/EMCProbes">http://www.ets-lindgren.com/EMCProbes</a>  <a href="http://www.narda-sts.us/products_highfreq_bband.php">http://www.narda-sts.us/products_highfreq_bband.php</a>

\* Specified as acceptable for use, but not required.

# 9010 FAST

High Speed. Low Uncertainty.

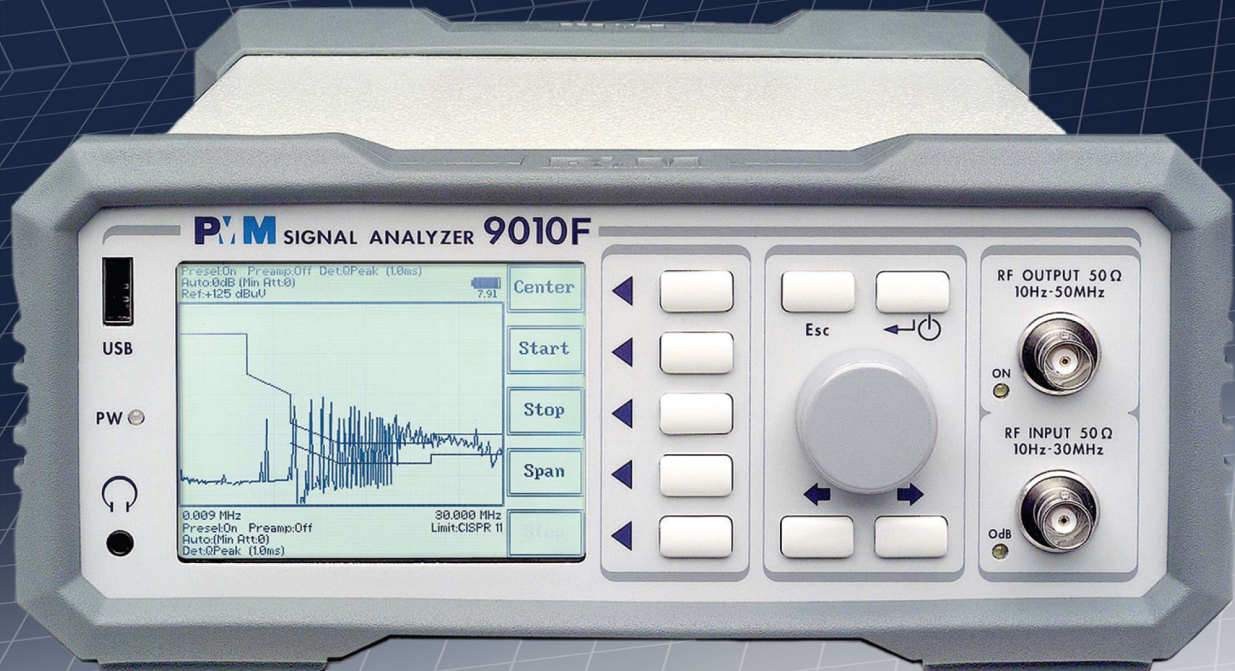

3 Extensions Receiver:

- 30 MHz - 3 GHz
- 30 MHz - 6 GHz
- 6 GHz - 18 GHz

New extension FR4003  
Rod Antenna and  
CISPR/MIL-STD EMI Receiver  
In a single solution

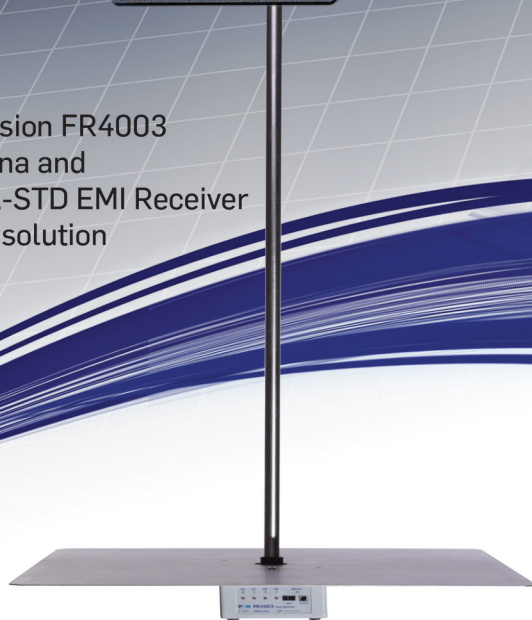

FFT Gapless EMI Receiver

Full compliance to CISPR and MIL-STD

Direct antenna mounting modules

Digital Fiber optic link up to 100m

**PIM**  
A BRAND OF

**narda**  
Safety Test Solutions®  
an  Communications Company



# EP-600 series

## USB/RS232 Electric Field Probes

EP-600 series features EP-600, EP-601, EP-602, EP-603, EP-604

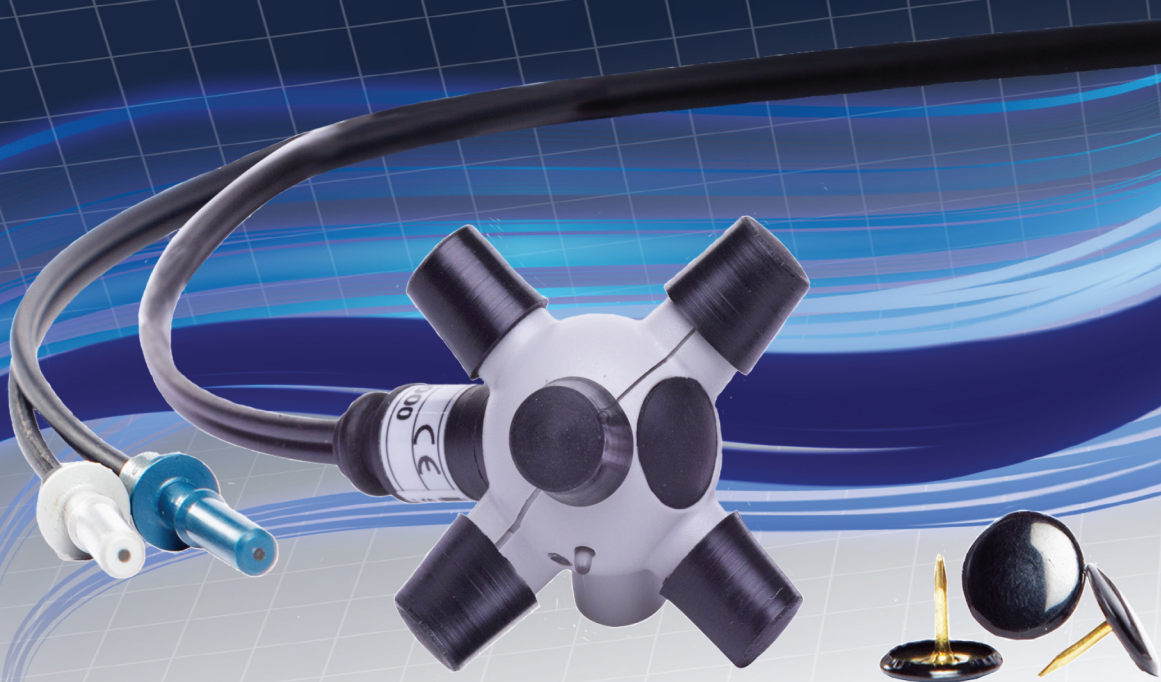

### Main Features

- 5 kHz to 26.5 GHz frequency range
- Up to 66 dB dynamic, single range
- Symmetrical dipole configuration
- Excellent isotropy (down to 0,2 dB typical)
- Up to 40 meters communication by Fiber Optic Cable
- Up to 80 hours of operation before recharging
- High performance, high reliability Li-Mn battery
- PC direct connection via Optical to RS232/USB adapters
- Extremely lightweight: 22 g only!

### The all-in-one that sets the standard for miniature optically coupled broadband E-field isotropic probes

Exceptionally small-sized spherical symmetrical configuration, lightweight and miniaturized electronics combined with excellent RF characteristics make the EP-600 series RF Electric Field Probes the ideal solution for all EMC/EMI applications (chambers and TEM/GTEM cells), biology and materials research and wherever fast and accurate measurements with negligible or minimum interference of the probe to the field under measure are essential. Accredited calibration on request.



# FR4003

## Field Receiver

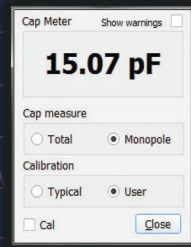

Start auto calibration					
Receiver (ADC)			Front End (BNC)		
Frequency (MHz)	Att:0 Voltmeter high Z (dB)	Att:0 Antenna (dB)	Att:10 Voltmeter high Z (dB)	Att:10 Antenna (dB)	Att:10 Antenna (dB)
1	0.009	2.68	-6.52	2.90	-6.52
2	0.01	2.70	-6.31	2.92	-6.31
3	0.02	2.69	-5.57	2.90	-5.57
4	0.05	2.69	-5.33	2.89	-5.33
5	0.08	2.71	-5.27	2.92	-5.27
6	0.1	2.71	-5.25	2.92	-5.25
7	0.15	2.72	-5.24	2.92	-5.24
8	0.2	2.70	-5.24	2.91	-5.24
9	0.5	2.70	-5.22	2.89	-5.22
10	0.8	2.69	-5.20	2.87	-5.20

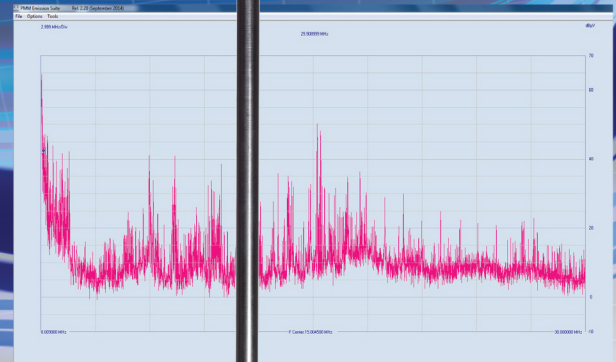
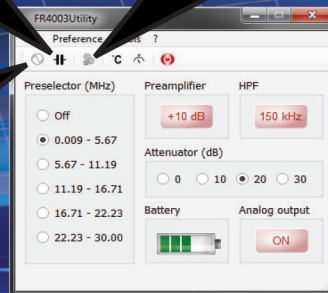
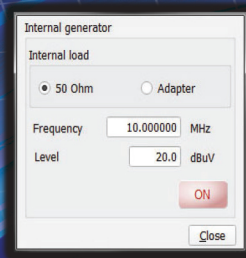

## Main Features

- 9 kHz to 30 MHz frequency range
- Antenna CISPR 12, CISPR 16, CISPR 25, MIL-STD, DO-160 fully compliant
- Internal full CISPR 16-1-1 receiver
- Embedded Attenuator, Preamplifier and Preselectors
- Fiber optic serial link to 9010F series or directly to PC
- Grounding Effectiveness Auto-Diagnostic Capability
- On board tracking generator and antenna CISPR adapter
- Automatic diagnostic and calibration
- Scattering free
- PC softwares
- RF Front-End Output
- On board capacitance meter
- Replaceable Li-Ion battery

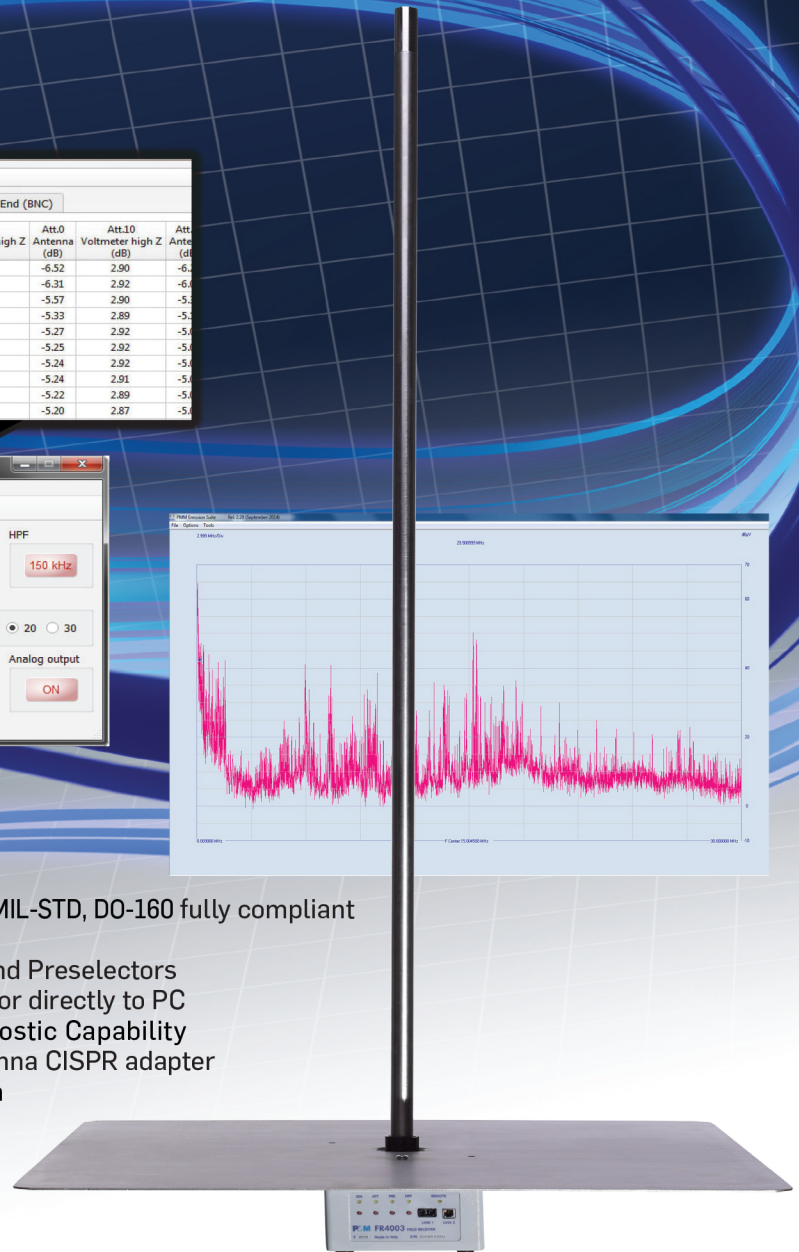

The FR4003 is a new reference in measuring electric fields up to 30 MHz. Thanks to its innovative approach it replaces traditional rod antennas adding several benefits. It fully meets all MIL-STD and CISPR specifications of the rod antenna and it is a real full compliant CISPR 16-1-1 receiver with the capability of working, via fiber optic link, either stand alone when connected to a PC or connected to a PMM receiver. Nonetheless, it can maintain full legacy with any standard receiver, because it also has the traditional coaxial cable output. However, this way is not recommended as the cable has a significant influence, such as scattering, which is one of the major drawbacks of rod antennas. The internal receiver structure features preselectors, attenuators and preamplifiers fully controlled either by the internal firmware or manually by the operator. Hence, a test set-up does not need any additional receiver. Moreover, an internal tracking generator allows performing a self-calibration procedure which always guarantees optimum performances, ensuring the accuracy of measurements. The same internal tracking generator is part of an internal capacitance meter that becomes essential not only for the self-calibration, but also for verifying the grounding effectiveness of the antenna. Last but not least, the FR4003 can become a field generator. In this case the antenna broadcasts the signal made by the internal signal generator and can thus be used to characterize environments or other receiving set-ups.

In addition to the standard PEMS software, the FR4003 comes also with a controlling software, which can be used when connected to a standard receiver. Thanks to its replaceable Li-Ion battery, the FR4003 can work for several hours with no connection having thus unperturbed field.



# L1-150M

# L1-150M1

## Multi-standard Single-path LISN



### Provided Features

- Powering the EUT
- EUT termination to a standardized impedance respect to the reference ground
- Coupling the measuring receiver to the disturbance generated by the EUT
- Decoupling the measuring receiver from unwanted RF signals from the power line

### Main Features

- L1-150M: 100 kHz to 200 MHz frequency range
- L1-150M1: 10 kHz to 400 MHz frequency range
- Multi standard design
- 150 A max output current
- Suitable also for DC lines
- Large baseplate for optimal grounding
- Robust, compact construction
- Screw terminals for safe wiring
- Meets the requirements of several standards including CISPR 16-1-2, CISPR 25, ISO 11452-2/4/5, ISO 7637-2, MIL-STD-461F, DO-160, ED-14G

The AMN - Artificial Mains Network, also known as LISN - Line Impedance Stabilization Network is the ancillary device intended for repeatable and accurate measurement of the disturbance voltage that an EUT (Equipment Under Test) may inject into the power line or mains.

This is obtained by providing well known impedance value and phase response across the frequency range of the test.

L1-150M and L1-150M1 are a single-path LISN (Line Impedance Stabilization Network) designed to be easily used for conducted disturbances measurements according to different standards for Automotive and ISM (Industrial, Scientific, Medical) applications. Selecting the standard is as fast as the turn of a rotary switch located on the rear panel. PMM Artificial Mains Networks provide robust and stable mechanical construction, high quality electric components, easy and perfect grounding, solid input and output power connections. They can be used in conjunction with any EMI receiver or spectrum analyzer and offer features required for safe, repeatable and accurate measurements.

# Introduction to DoD Policy, Guidance, and the Acquisition Process

---

## **TONY KEYS**

EMC Analytical Services

## **BRIAN FARMER**

EMC Management Concepts

This article provides an introduction to DoD policy, guidance and the acquisition process. E3 is defined as the impact of the Electromagnetic Environment (EME) upon the operational capability of military forces, equipment, systems, and platforms. E3 encompasses all electromagnetic disciplines, including Electromagnetic Interference and Electromagnetic Compatibility (EMI/EMC); Electromagnetic Vulnerability (EMV); Electromagnetic Pulse (EMP); natural phenomena such as lightning, electrostatic discharge (ESD) and precipitation static; and Hazards of Electromagnetic Radiation to Personnel (HERP), Ordnance (HERO), and Fuel (HERF). In addition, Spectrum Supportability must be addressed in conjunction with E3 for Spectrum Dependent (S-D) systems.





Early consideration of E3 and Spectrum Supportability (SS) in electronic and S-D systems is a fundamental criterion that must be satisfied before communications-electronics (CE) equipment and related weapons systems are developed and fielded. Development or acquisition of systems that meet operational requirements, but are not electromagnetically compatible or fail to obtain spectrum supportability, creates a potential for severe mutual interference between themselves and other spectrum users, squanders resources, and delays fielding warfighting capabilities to field units.

Equipment, subsystems and systems employed for military purposes are exposed to extreme EMEs. Providing the warfighter with systems that will operate within these extreme EMEs requires specific requirements, design and test considerations. This new mini guide from Interference Technology will review E3 related policies and requirements specific to military equipment, subsystems and systems, from a top down perspective, including overviews of MIL-STD-464C and MIL-STD-461G, a listing of relevant military E3 related documents and points of contact.

### **Real World Operational Impacts/Examples**

There are many examples of EMC and spectrum supportability problems in military systems which have caused serious, and even catastrophic, operational and programmatic problems. Some examples include:

Between 1981 and 1987, several UH-60 Blackhawk helicopters nose-dived and crashed, killing 22 servicemen. The crashes were attributed to insufficient flight control immunity to high intensity radiated fields when flying past radio broadcast towers. This interference produced uncommanded control surface movements causing fatal dives.

The US Air Force has had to address a potential frequency-interference issue with their B-2 bombers. Analysis indicates a high probability of the Raytheon AN/APQ-181 radar system on the B-2As interfering with commercial satellite communications after 2007. The B-2's radar would most likely disrupt their transmissions and could damage commercial communications satellites, for which the USAF likely would

be liable, according to industry sources. The total estimated cost is expected to exceed \$1.3B.

An AV-8B Harrier was lost and the pilot killed as a result of the indirect effects of a lightning strike. The lightning strike caused large internal electrical currents inside the wing. A coupler inside the wing fuel tank system was not designed to withstand such a current flowing across it and sparked, causing a fuel explosion.

While there have been these and other catastrophic examples, the vast majority are simply performance degradation problems that put our fighting forces at risk, delay fielding of important capabilities or stretch budgets beyond their limits.

### **DOD Policy and Perspective**

The need for control of the electromagnetic spectrum and the EME is understood at the highest levels of DoD management and military operational directors, who must ensure that U.S. Forces have the ability to operate effectively in all domains: space, sea, land, air, information; and can conduct operations with a combination of forces tailored to different situations. Military success relies on Information Superiority: Obtaining, processing, distributing, and protecting accurate information while exploiting or denying the adversary's ability from doing the same. Much of the information superiority depends on access to the RF spectrum. The priority placed on force mobility, range, and speed dictates that much of the information technology be wireless. Again, the critical medium is the EM spectrum with EMI free operations.

Spectrum dominance is a cornerstone of the DoD's warfighting strategy. To maintain this spectrum dominance, the spectrum and system EMC within the spectrum must be carefully controlled. While EMI (including interference caused by spectrum management problems) can cause catastrophic problems, the majority of interference problems render systems less than fully effective, which reduces operational readiness and increases costs. These may be hard to see, and more difficult to quantify in terms of return on investment; however, taking care of E3 and Spectrum Certification requirements early on in a program provides significant future cost savings. Figure 1 illustrates the concept of spectrum dominance.

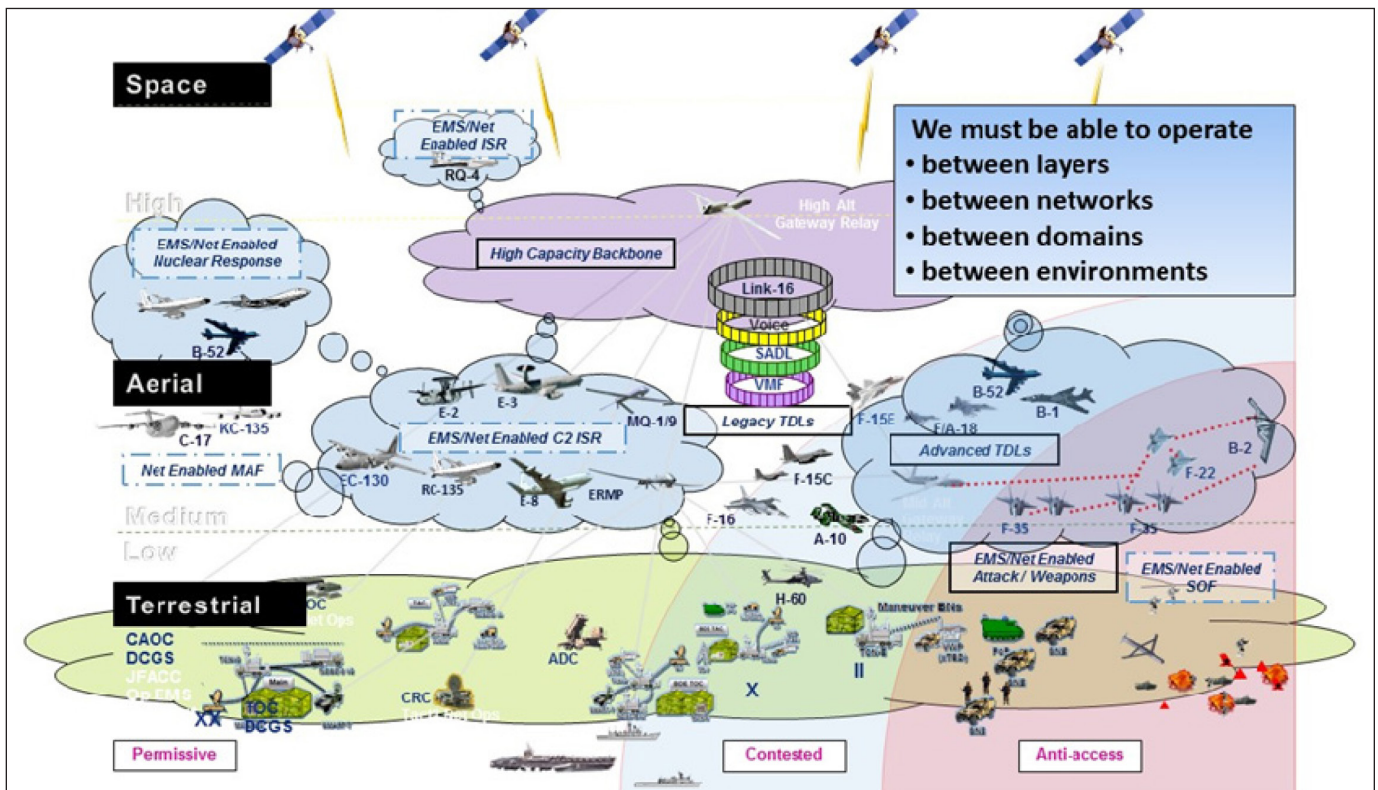

FIGURE 1: Spectrum Dominance Illustration

**Acquisition Process**

The military procurement system is driven by high level policies that flow down to processes and procedures covering anything that is considered a technical requirement. E3 and SS are no different. There are high level policies that require programs to consider E3 and SS in system design, procurement and fielding as well as policies requiring that military systems follow the rules of frequency use. The two most significant top level directives that require spectrum management and E3 control in the acquisition cycle are:

**DODI 3222.03 DoD Electromagnetic Environmental Effects (E3) Program, 24 Aug 2014**

This Instruction drives the requirement that “All electrical and electronic systems, subsystems, and equipment, including ordnance containing electrically initiated devices, shall be mutually compatible in their intended EME without causing or suffering unacceptable mission degradation due to E3.” It identifies many high level DoD organizations and outlines their responsibilities for E3 control within systems acquisition and operational communities.

**DoD Instruction 4650.01, Policy and Procedures for Management and Use of the Electromagnetic Spectrum, 09 Jan 2009**

This instruction outlines the requirements for DoD spectrum use to ensure that systems can operate without interference. Some requirements include:

- Obtaining a written determination that there is reasonable assurance of Spectrum Supportability for DoD organizations developing or acquiring spectrum-dependent equipment.
- Applicability of Spectrum Supportability determination requirements for “off-the-shelf” or other non-developmental systems (including commercial items).
- The requirement to produce a Spectrum Supportability Risk Assessment (SSRA) to identify and assess an acquisition’s potential to affect the required performance of the newly acquired system or other existing systems within the operational EME. SSRAs identify SS and E3 risks and the steps that need to be taken to mitigate the risks.



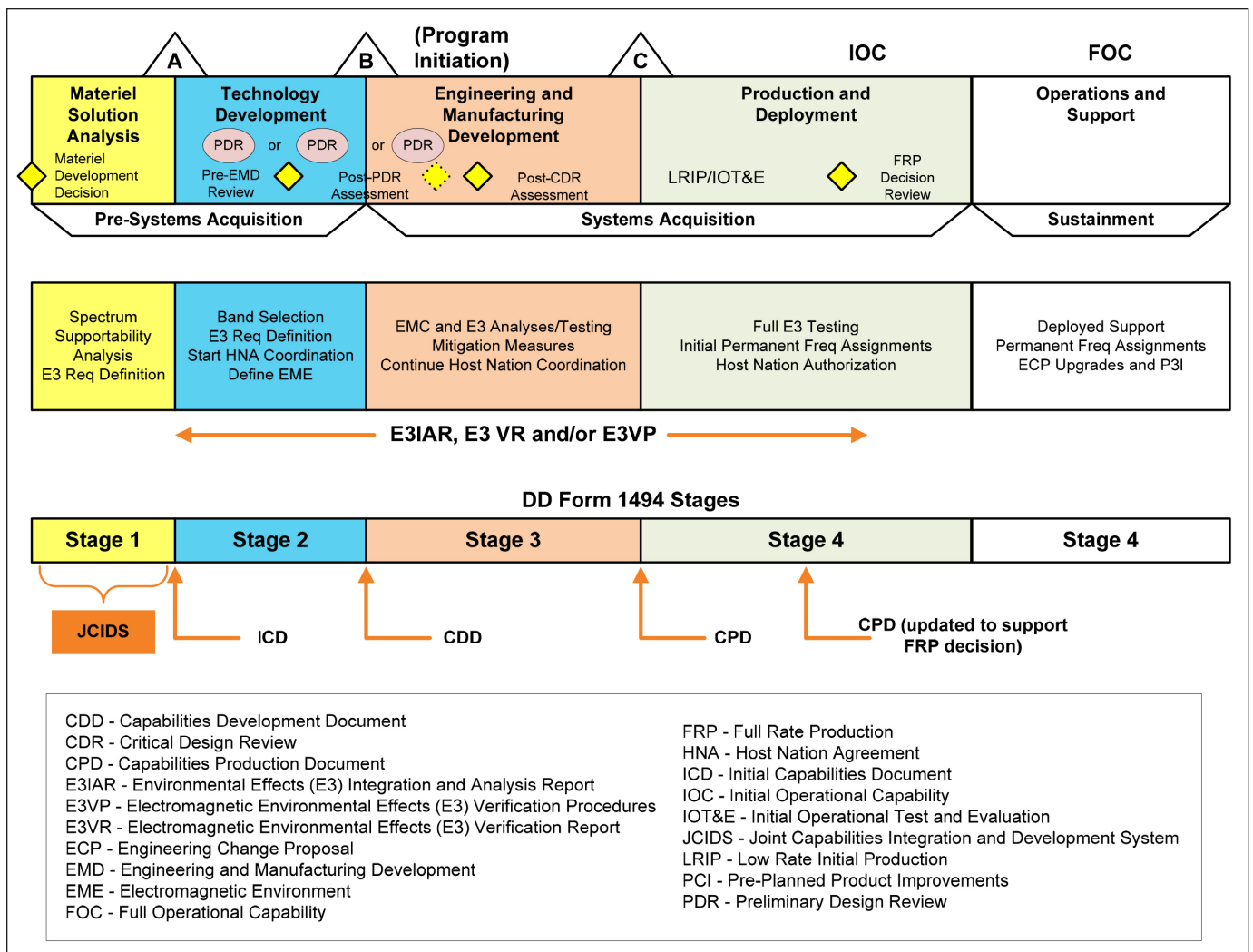

FIGURE 2: E3 and SS Processes

The fundamental E3 and SS related processes and tasks over the military system procurement cycle are shown in Figure 2.

### About the Author

Tony Keys is the President and Principal Consultant for EMC Analytical Services. Mr. Keys has over 20 years of experience in Electromagnetic Environmental Effects (E3) engineering. His experience covers a wide range of E3 specialty areas from a multitude of organizational aspects including E3 support contracting, DoD E3 service, and DoD system development. He can be reached at [tony.keys@emcanalyticalservices.com](mailto:tony.keys@emcanalyticalservices.com).

The author would like to thank Brian Farmer for his significant contribution to the article.

Brian Farmer has a long career providing E3 and Spectrum Supportability systems engineering and program management services to the DoD, including the Naval Air Systems Command (NAVAIR), the Joint Spectrum Center (JSC) and the Naval Surface Warfare Center Dahlgren Division. After working for several companies in the E3 engineering business, Brian formed EMC Management Concepts in 2002. In addition to being CEO of EMC Management Concepts, Brian still provides direct E3 program management support to several Navy offices and the JSC. He leads contract efforts to develop and deliver E3 and Spectrum Supportability training to the acquisition community. He can be reached at [bdfarmer@emcmanagement.com](mailto:bdfarmer@emcmanagement.com).

# your avionics testing

Ensure aircraft safety with a multi-function lightning simulation test platform. The Thermo Scientific™ ECAT™ Lightning Test System (LTS) is a modular test platform that delivers reliable, repeatable results that meet multiple avionics standards, including RTCA DO-160 and CS-117 (MIL-STD-461G). The ECAT LTS performs Pin Injection, Cable Bundle, and Ground Injection testing with Single Stroke, Multiple Stroke and Multiple Burst modes, so you can be sure your components meet the performance standards of the aircraft's most critical systems.

## simplified



**Thermo**  
SCIENTIFIC

A Thermo Fisher Scientific Brand

• see more compliance testing solutions at [thermoscientific.com/esd](http://thermoscientific.com/esd)

• Helping to ensure that your critical systems and components meet compliance standards.



# Spectrum Management and the EME

---

## **TONY KEYS**

EMC Analytical Services

## **BRIAN FARMER**

EMC Management Concepts

This article provides an introduction to Spectrum Management and defining the EME (Electromagnetic Environment).



**Certification**

In years past, E3 (Electromagnetic Environment Effects) control and Spectrum Supportability were considered separate entities and design and development efforts were often segregated. Over the last several years, the trend has shifted to a more consolidated approach and today the two areas go hand in hand. Spectrum Supportability starts with equipment spectrum certification, essentially a license to operate a system in a particular spectrum band. Spectrum certification is the authorization to develop or procure a spectrum-dependent system for operation in specific frequency bands. It is accomplished using the DD Form 1494, Application for Equipment Frequency Allocation, via the J-12 Process and is based on regulatory requirements. The DD Form 1494 provides the information required to determine whether the subject system meets the criteria established by the allocation tables. Potential impacts to current band users are also consid-

ered by approval authorities. The bottom diagram in Figure 1 maps the stages of the DD Form 1494 to the procurement cycle.

**Defining the EME**

From an EMC requirements perspective, one of the very first tasks is to define the operational EME for the platform or system of interest. It is extremely important to properly define the various EMEs in which the item is most likely to operate as this forms the basis of accurate E3 design and test requirements. The EME is the composite of electromagnetic energy, including man-made and natural sources, to which a system or subsystem/equipment will be exposed during its operational life cycle. It takes into account the expected areas of operation, other S-D (Spectrum Dependent) systems, including emitters that may be in that area. It also includes natural sources such as lightning and ESD. The EME is an ever changing evolution created by the demand for

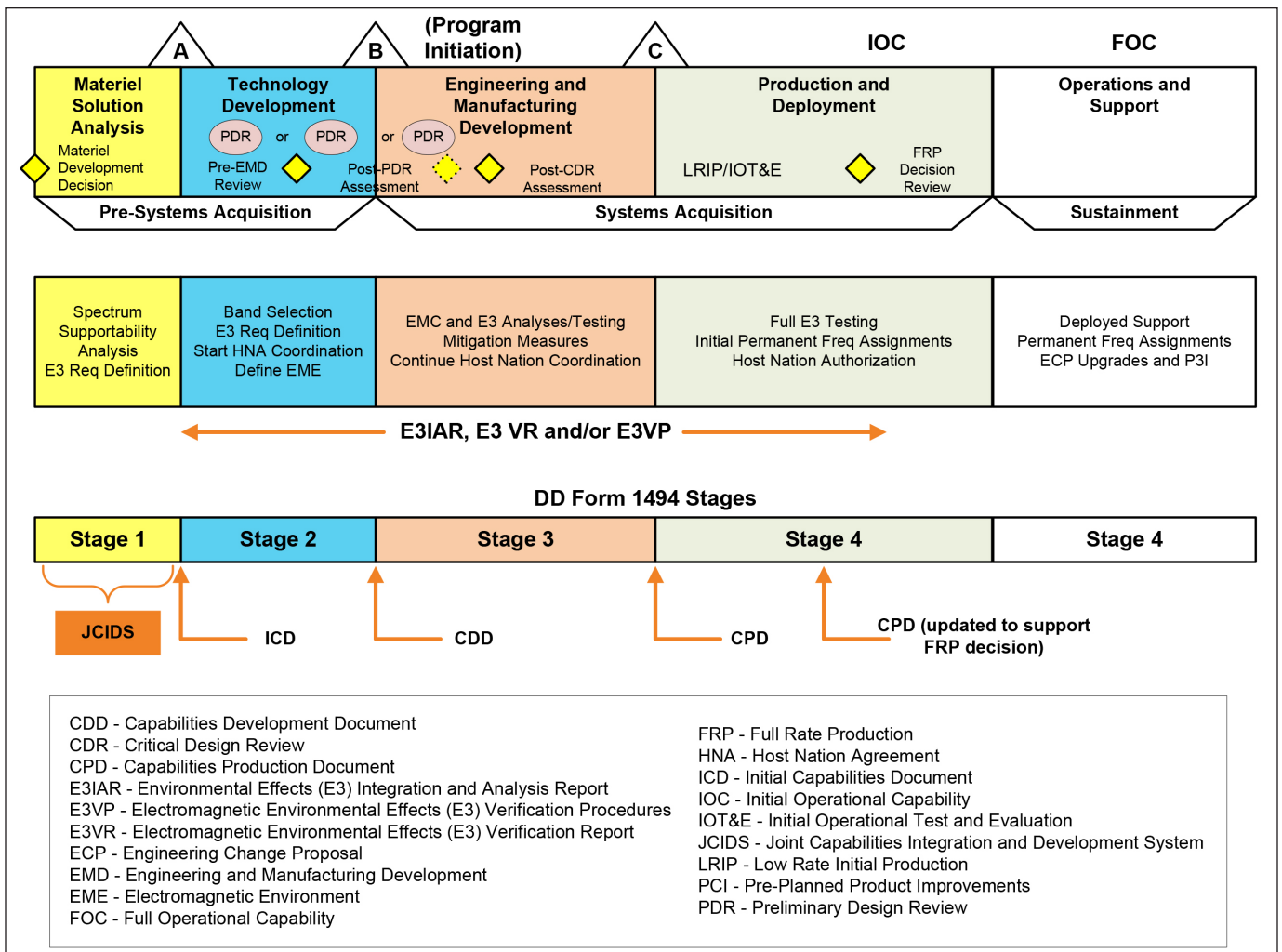

FIGURE 1: E3 and SS Processes



more radiated power and different or more common platforms in a given area.

Steps in this process include:

- Identifying the major geographic regions in which the system will operate, that is, the U.S., Atlantic, Pacific, Europe, Middle East, or possibly, worldwide.
- Identifying the specific countries in each major region in which the item is likely to be deployed, since obtaining host nation approval to operate may be more challenging in some countries.
- Defining the theater and missions.
- Identifying individual host platforms and systems on or near the item to be deployed.
- Identifying types and characteristics of any S-D item present or planned that could possibly interact with the proposed item. This identification addresses both items affected by and those that affect the item. The identification must address both the military and commercial EME alike.

Specifying an EME that is too stringent may result in additional costs in design and test phases that are unnecessary by qualifying a system to an overly harsh EME. Each distinctive EME that an item will be exposed to during its life cycle should be defined before specifying its performance requirements. For example, a missile will be exposed to different EME levels during shipment, storage, checkout, launch, and the approach to a target. The specified E3 performance requirements should ensure the item's performance is not adversely affected by any of the EME levels that will be encountered. The majority of military systems begin establishing E3 related requirements based on MIL-STD-464 (currently at Revision C).

MIL-STD-464C identifies five key activities that comprise an E3 integration approach.

- a. Establish the external threat environment against which the system is required to demonstrate compliance of immunity. The external environments (EME, lightning and EMP) to which the system should be designed and verified are addressed in other sections of this appendix.
- b. Identify the system electrical and electronic equipment performing functions required for operation during application of the external threat. Normally all functions essential for com-

pleting the missions are protected against the external threats.

- c. Establish the internal environment caused by external electromagnetic effects for each installed equipment. All of the environments external to the system specified in this standard cause related environments internal to the system. The level of this internal environment will be the result of many factors such as structural details, penetration of apertures and seams, and system and cable resonances. The internal environment for each threat should be established by analysis, similarity to previously tested systems, or testing. The internal environment is usually expressed as the level of electrical current stresses appearing at the interface to the equipment or electromagnetic field quantities. These internal stresses are typically associated with standardized requirements for equipment (for example, MIL-STD-461). Trade-offs need to be made of the degree of hardening to be implemented at the system-level (such as shielded volumes or overbraiding on interconnecting wiring) versus equipment-level (more stringent electromagnetic interference requirements) to establish the most effective approach from performance and cost standpoints.
- d. Design the system and equipment protection. System features are then designed as necessary to control the internal environment (including margin considerations) to levels determined from the trade-off studies and appropriate requirements are imposed on the electrical and electronic equipment. The equipment immunity levels must be above the internal environments by necessary margins to account for criticality of the equipment, manufacturing tolerances, and uncertainties in verification. Normally there are design and test requirements in MIL-STD-461 applicable for each of the external environments, but they may need modification for the particular system application. For example, the external environment may result in internal environments above the susceptibility level specified in MIL-STD-461. If so, the limit must be tailored for the particular system, alternative requirements must be imposed or the internal environment must be reduced to an acceptable level. The system E3 design must be viable throughout the system life cycle. This aspect requires an awareness of proper application of corrosion control provisions and issues related

to maintenance actions that may affect EMC. Examples are ensuring that electrical bonding provisions are not degraded, maintaining surface treatments in place for E3 control, and considering exposure of electronics to EMEs when access panels are open. Maintaining a viable system E3 design also requires an effective configuration management program for tracking and evaluating engineering changes to the system to ensure that the E3 design is not compromised.

- e. Verify the protection adequacy. The system and equipment E3 protection design must be verified as meeting contractual requirements. Verification of the adequacy of the protection design includes demonstrating that the actual levels of the internal environments appearing at the equipment interfaces and enclosures do not exceed the qualification test levels of the equipment for each environment by required margins. All electronic and electrical equipment must have been qualified to their appropriate specification level. Systems-level testing is normally required to minimize the required margin demonstration. Analysis may be acceptable under some conditions; however, the required margins will typically be larger.

agement support to several Navy offices and the JSC. He leads contract efforts to develop and deliver E3 and Spectrum Supportability training to the acquisition community. He can be reached at [bd-farmer@emcmanagement.com](mailto:bd-farmer@emcmanagement.com).

### About the Author

Tony Keys is the President and Principal Consultant for EMC Analytical Services. Mr. Keys has over 20 years of experience in Electromagnetic Environmental Effects (E3) engineering. His experience covers a wide range of E3 specialty areas from a multitude of organizational aspects including E3 support contracting, DoD E3 service, and DoD system development. He can be reached at [tony.keys@emcanalyticalservices.com](mailto:tony.keys@emcanalyticalservices.com).

The author would like to thank Brian Farmer for his significant contribution to the article.

Brian Farmer has a long career providing E3 and Spectrum Supportability systems engineering and program management services to the DoD, including the Naval Air Systems Command (NAVAIR), the Joint Spectrum Center (JSC) and the Naval Surface Warfare Center Dahlgren Division. After working for several companies in the E3 engineering business, Brian formed EMC Management Concepts in 2002. In addition to being CEO of EMC Management Concepts, Brian still provides direct E3 program man-



# MIL-STD-461 TESTING

## SIMPLIFIED WITH PEARSON PRODUCTS

### CS114/115/116

### CS101



New Injection Probe, Current Probe and Test Fixture specifically designed for sections CS114/115/116 in MIL-STD-461 (including "G") and RTCA/DO-160 requirements.

- Consists of 3 Components
  - 8700i Injection Probe
  - 8705C Current Probe
  - F-3 Test Fixture (accommodates both probes)
- Wideband response - 10 kHz to 400 MHz
- Max Input Power - 100W for 30 minutes
- Max RMS Current - 4 Amps
- Max Peak Current - 15 Amps
- Compact design with 2.0 inch aperture

Greatly simplifies the measurement of injected audio-frequency ripple on an AC or DC power bus in EMI tests such as MIL-STD-461G CS101.

- Two Models - PRD-120 & PRD-240
- Measure audio frequency (CS101) ripple injected on power buses
- Separates ripple from power waveform
- Used with a spectrum analyzer
- Max Voltage 120-240 Vac, 270 Vdc
- Switch selectable frequency response:
  - Flat response 10 Hz to 150 kHz
  - CS101 setting provides constant output over entire frequency range



# Introduction to MIL-STD-464C

---

**TONY KEYS**  
EMC Analytical Services





Responding to increasing criticism, Secretary of Defense William Perry issued a memorandum in 1994 that effectively eliminated the use of most defense standards. This has become known as the “Perry memo”. Many defense standards were cancelled. In their place, the DOD encouraged the use of industry standards for quality assurance. MIL-STD-464 was developed as an “Interface Standard” to allow usage without a waiver. The E3 (Electromagnetic Environmental Effects) area addresses a number of interfacing issues with environments both external to the system and within the system. Each system must be compatible with itself, other systems, and the external environment to ensure required performance. MIL-STD-464C is a standard to establish requirements for how systems must interface with each other in the E3 arena. It provides E3 interface requirements and verification criteria and applies to complete airborne, sea, space, and ground systems, including associated ordnance. It applies to both new and modified systems. What it does not provide is pass/fail criteria and test procedures. It should be noted that while MIL-STD-464C is a system/platform level interface standard and is not intended to be used directly for equipment and subsystems, it is the origin of E3 requirements flow down to equipment and subsystems.

This standard contains two sections, the main body and an appendix. The main body of the standard defines a baseline set of E3 requirements and provides specific guidance to different categories, e.g. intra-system EMC, shipboard internal EME, external RF EME and various other E3 disciplines. It also includes sections on notes, information on Data Item Descriptions, tailoring guidance, references to similar NATO documentation and points of contact.

The appendix provides rationale, guidance, and lessons learned for each requirement to enable the procuring activity to tailor the baseline requirements for a particular application. The appendix also permits government and industry personnel to understand the purpose of the requirements and potential verification methodology for a design. The appendix is not a mandatory part of this document but is critical to understanding the standard. It is often said that if someone wants to understand MIL-STD-464C, they should skip straight to the appendix! The following sections will review the detailed requirements cited in MIL-STD-464C.

## Margins

Due to the variability in hardware and production processes for a given system, MIL-STD-464C requires that margins be provided based on system operational performance requirements, tolerances in system hardware, and uncertainties involved in verification of system-level design requirements. Specifically, safety critical and mission critical system functions require a margin of at least 6 dB. Electrically initiated Devices (EIDs) require a margin of at least 16.5 dB of the maximum no-fire stimulus (MNFS) for safety assurances and 6 dB of MNFS for other applications. Margins are typically levied on systems for specific environments external to the system. In general, these include direct effects of lightning, Electromagnetic Pulse (EMP) and Hazards of Electromagnetic Radiation to Ordnance (HERO).

A common misconception is that the application of margin requirements is an increase in the requirement level. This is not the intent of the requirement. In fact, the most common approach for verifying margins is to monitor currents and/or voltages during testing at the requirement level and demonstrate margins based on equipment strength as opposed to over testing. In the case of space based systems, determining and verifying margin requirements is critical due to the inherent inability to repair or replace components.

## Intra-System EMC

As obvious as it may seem, MIL-STD-464C provides requirements for and addresses Intra-System EMC. Specifically, the requirements state, “The system shall be electromagnetically compatible within itself such that system operational performance requirements are met. Compliance shall be verified by system-level test, analysis, or a combination thereof.” The majority of intra-system EMC issues involve antenna-connected transmitters and receivers such as degraded receiver performance due to electromagnetic fields radiated from onboard antennas. Ensuring intra-system EMC is typically accomplished by a combination of analysis and test.

Surface ship applications must contend with Intermodulation Interference (IMI) concerns. When two signals of different frequencies mix in a non-linear junction, a signal is created at an intermodulation frequency. When an antenna-connected receiver is

tuned to the intermodulation frequency, interference may occur. The intra-system EMC requirement is considered to be met for hull generated IMI when IMI product orders higher than 19th order produced by High Frequency (HF) transmitters installed onboard ship are not detectable by antenna-connected receivers onboard ship.

In addition to controlling hull generated IMI, limits are placed on the maximum EME allowed in internal spaces on board surface ships and submarines. The requirements for surface ships are specified for both metallic and non-metallic hulls. Metallic hulls are limited to 10 V/m from 10 kHz to 18 GHz and non-metallic hulls are limited to 10 V/m from 10 kHz to 2 MHz, 50 V/m from 2 MHz to 1 GHz and 10 V/m from 1 GHz to 18 GHz. The increased use of wireless systems below decks, is considered as well with limitations placed on the effective isotropic radiated power (EIRP) and the total radiated power (TRP). For metallic hulls, the EIRP is limited to a maximum of 100 mW and the total combined power radiated within a compartment and within the operating frequency band is limited to 550 mW TRP. For non-metallic hulls, the EIRP is limited to a maximum of 100 mW and the total combined power radiated within a compartment and within the operating frequency band is limited to 13.75 W TRP. For submarines, the limits are 5 V/m from 10 kHz to 30 MHz and 10 V/m from 30 MHz to 18 GHz with and the EIRP is limited to a maximum of 25 mW and the total combined power radiated within a compartment and within the operating frequency band is limited to 50 mW TRP. In all cases, no transmitting devices are allowed to be permanently installed within 1 meter of safety or mission critical equipment.

Multipaction occurs when RF fields accelerate electrons in a vacuum and cause them to impact with a surface, which may release additional electrons into the vacuum. These electrons can then be accelerated by the RF fields and impact with the same or another surface. If the frequency of the signal is such that the RF field changes polarity in concert with the production of the secondary electrons, the secondary electrons are then accelerated resulting in more electrons leading to potential interference

or damage. MIL-STD-464C requires that equipment and subsystems used in space applications be free of multipaction effects.

Unintentional radiated emissions coupled to antennas can be above the noise floor of receivers resulting in performance degradation and hence the signals present at antenna ports of antenna-connected receivers must be controlled. The most common unintentional emissions are caused by microprocessor clock harmonics and cable radiation, however, other sources may also be present.

### External EME

Perhaps the most commonly invoked requirement from MIL-STD-464C is the external EME. This area also tends to be the most complicated requirement to verify for a number of reasons. MIL-STD-464C presents several tables defining the EME for particular installations and applications. In all, there are six tables provided:

Table 1 – External EME for deck operations on ships

Table 2 – External EME for shipboard operations in the main beam of transmitters

Table 3 – External EME for space and launch vehicle systems

Table 4 – External EME for ground systems

Table 5 – External EME for Army rotary wing aircraft

Table 6 – External EME for fixed wing aircraft, excluding shipboard operations

In addition, the appendix provides an EME table for specialized Army rotorcraft testing.

The tables provide peak and average E-Field levels over frequency and were developed based on MIL-HDBK-235. The external EMEs are shown in Tables 1 through 6.



Frequency Range		Shipboard Flight Decks		Shipboard Weather Decks	
		Electric Field (V/m-rms)		Electric Field (V/m-rms)	
(MHz)	(MHz)	Peak	Average	Peak	Average
0.01	2				
2	30	164	164	169	169
30	150	61	61	61	61
150	225	61	61	61	61
225	400	61	61	61	61
400	700	196	71	445	71
700	790	94	94	94	94
790	1000	246	100	1307	244
1000	2000	212	112	112	112
2000	2700	159	159	159	159
2700	3600	2027	200	897	200
3600	4000	298	200	1859	200
4000	5400	200	200	200	200
5400	5900	361	213	711	235
5900	6000	213	213	235	235
6000	7900	213	213	235	235
7900	8000	200	200	200	200
8000	8400	200	200	200	200
8400	8500	200	200	200	200
8500	11000	200	200	913	200
11000	14000	744	200	833	200
14000	18000	744	200	833	200
18000	50000	200	200	267	200

TABLE 1: External EME for Deck Operations on Ships

Frequency Range		Main Beam (distances vary with ship class and antenna configuration)	
		Electric Field (V/m-rms)	
MHz	MHz	Peak	Average
0.01	2		
2	30	200	200
30	150	10	10
150	225	10	10
225	400	43	43
400	700	2036	268
700	790	10	10
790	1000	2528	485
1000	2000	930	156
2000	2700	10	10
2700	3600	*27460/12667	*2620/1533
3600	4000	8553	272
4000	5400	139	139
5400	5900	3234	267
5900	6000	267	267
6000	7900	400	400
7900	8000	400	400
8000	8400	400	400
8400	8500	400	400
8500	11000	4173	907
11000	14000	3529	680
14000	18000	3529	680
18000	50000	2862	576

TABLE 2: External EME for Shipboard Operations in the Main Beam of Transmitters



# ADVANCES GaN AMPLIFIER TECHNOLOGY

## RF/Microwave Amplifiers

SMC SERIES 80 - 1000 MHz: 10 – 3000 watts



SMC1000, 80-1000MHz, 1000 watts

S61 Series 700-6000 MHz: 10 – 400 watts



S61-100, 1.0-6.0GHz 100 watts

Improvements in solid-state power amplifiers depend on advances in transistors. The Engineers at IFI continuously receive the most current transistor technology available by working closely with all the transistor foundries. Fortunately, evolving gallium nitride (GaN) high-electron-mobility-transistor (HEMT) technology is bringing many benefits to high-frequency amplifier designers here at IFI. A key advantage of GaN HEMT devices operating at > 1000 MHz compared to other transistor technologies is the high power density possible from relatively small transistor cells.

These advancement have allowed IFI's design team to develop for the market some of the smallest high power amplifiers currently available. The SMC series operate over 80-1000MHz and produce 1000 watts in an ultra-small 10.5"H (6U) chassis. The S61 series operates over 700-6000MHz and can produce 100 watts in an ultra-small 5.25"H (3U) chassis. The Amplifiers provide outstanding RF performance. These products are available in a wide range of power levels from 10 watts to 3000 watts for the 80 – 1000 MHz frequency range. These state-of-the-art solid-state power amplifiers are specifically designed for laboratory and all testing applications. IFI RF amplifiers are very conservatively designed to operate below maximum ratings for ruggedness and long term reliability.

So call IFI at 631-467-8400 to discuss your specific requirements.

**Instruments for Industry**

903 South 2nd Street • Ronkonkoma, NY 11779

Tel: 631-467-8400 • Fax: 631-467-8558 • sales@ifi.com • www.ifi.com

**AMETEK**<sup>®</sup>  
COMPLIANCE TEST SOLUTIONS



Frequency Range		Electric Field (V/m-rms)	
MHz	MHz	Peak	Average
0.01	2	1	1
2	30	73	73
30	150	17	17
150	225	4	1
225	400		
400	700	47	6
700	790	1	1
790	1000	7	7
1000	2000	63	63
2000	2700	187	187
2700	3600	23	8
3600	4000	2	2
4000	5400	3	3
5400	5900	164	164
5900	6000	164	164
6000	7900	6	6
7900	8000	3	1
8000	8400	1	1
8400	8500	3	1
8500	11000	140	116
11000	14000	114	114
14000	18000	16	9
18000	50000	23	23

TABLE 3: External EME for Space and Launch Vehicle Systems

Frequency Range		Electric Field (V/m-rms)	
MHz	MHz	Peak	Average
0.01	2	73	73
2	30	103	103
30	150	74	74
150	225	41	41
225	400	92	92
400	700	98	98
700	790	267	267
790	1000	284	267
1000	2000	2452	155
2000	2700	489	155
2700	3600	2450	219
3600	4000	489	49
4000	5400	645	183
5400	5900	6146	155
5900	6000	549	55
6000	7900	4081	119
7900	8000	549	97
8000	8400	1095	110
8400	8500	1095	110
8500	11000	1943	139
11000	14000	3454	110
14000	18000	8671	243
18000	50000	2793	76

TABLE 4: External EME for Ground Systems

Frequency Range		Electric Field (V/m-rms)	
MHz	MHz	Peak	Average
0.01	2	200	200
2	30	200	200
30	150	200	200
150	225	200	200
225	400	200	200
400	700	1311	402
700	790	700	402
790	1000	700	402
1000	2000	6057	232
2000	2700	3351	200
2700	3600	4220	455
3600	4000	3351	200
4000	5400	9179	657
5400	5900	9179	657
5900	6000	9179	200
6000	7900	400	200
7900	8000	400	200
8000	8400	7430	266
8400	8500	7430	266
8500	11000	7430	266
11000	14000	7430	558
14000	18000	730	558
18000	50000	1008	200

TABLE 5: External EME for Army Rotary Wing Aircraft

Frequency Range		Electric Field (V/m-rms)	
MHz	MHz	Peak	Average
0.01	2	88	27
2	30	64	64
30	150	67	13
150	225	67	36
225	400	58	3
400	700	2143	159
700	790	80	80
790	1000	289	105
1000	2000	3363	420
2000	2700	957	209
2700	3600	4220	455
3600	4000	148	11
4000	5400	3551	657
5400	5900	3551	657
5900	6000	148	4
6000	7900	344	14
7900	8000	148	4
8000	8400	187	70
8400	8500	187	70
8500	11000	6299	238
11000	14000	2211	94
14000	18000	1796	655
18000	50000	533	38

TABLE 6: External EME for Fixed Wing Aircraft, Excluding Shipboard Operations



The values in the tables are often cost drivers in design and must be considered from the very early stages of development. The actual RF EME is defined by a multitude of sources and the same transmitter does not necessarily drive the peak and average levels in a particular frequency range in any table. The contribution of each emitter may be described in terms of its individual characteristics including: power level, modulation, frequency, bandwidth, antenna gain (main beam and sidelobe), antenna scanning, and so forth. The EME tables provide a starting point for an analysis to develop the actual external radiated field environment based on the system's operational requirements. The actual EME may be either lower or higher for any given frequency range depending on the operational requirements. For all systems, the appropriate environment defined in MIL-HDBK-235 may be extracted and used for tailoring. During analysis for sensitive receiving systems, it is important to note that the source emitter that produces the highest peak or average EME from the table may or may not be the most problematic emitter within a given frequency range. It is imperative to understand the entire EME, and not just the top level emitters.

Testing at full threat levels is typically performed very late in the program development cycle due to cost and schedule restraints. Engineering level testing and direct injection testing should be performed when possible to support analytical efforts.

### High Power Microwave (HPM)

HPM weapons are known to produce pulse peak power of 100 Megawatts or larger. The source can be located/delivered via a number of options including ground vehicles, airborne vehicles, man portable systems and even ground structures. Narrowband sources utilize pulsed power to drive an electron beam diode or similar load that ultimately converts electron kinetic energy into coherent electromagnetic radiation. Wideband, including ultra-wideband (UWB), HPM sources utilize fast switching techniques to drive impulse generators. HPM source frequency ranges have the capability to penetrate not only radio front-ends, but also small shielding penetrations in system or equipment enclosures. At sufficiently high levels, the potential exists for damage to devices and circuits. However, induced voltages from fields are inversely proportional to wavelength at frequencies where the equipment is multiple wavelengths long. The obvious counter-measure is

to shield or harden electronic equipment. Currently, only flight critical and mission critical systems and equipment are hardened.

HPM represents a unique EME and determining the appropriate HPM environment tests levels requires detailed knowledge of the HPM weapon and its engagement scenario, the operational scenario of the target system to protect, and the shielding from the surrounding infrastructure. HPM requirements are applicable only if specifically invoked by the procuring activity. The appendix in MIL-STD-464C provides generic HPM EMEs for both narrowband and broadband sources, however, MIL-HDBK-235 and the individual Capstone Threat Assessment Reports must be used to provide specific threat information. The appendix also provides a very useful generic example approach to tailoring the HPM requirement.

### Lightning

MIL-STD-464C divides lightning into direct and indirect effects. Direct effects can best be described by physical damage or evidence of physical damage such as burning and eroding, blasting, and structural deformation. Indirect effects can best be described as effects resulting from the electromagnetic fields associated with lightning and the interaction of these electromagnetic fields with equipment in the system. Additionally, a system can be impacted by nearby lightning strikes that do not actually produce direct contact with the system. Aircraft can be exposed to naturally occurring strikes or may initiate the lightning strike. It is believed that aircraft triggered lightning is the more common event.

MIL-STD-464C requires systems to meet operational performance requirements for both direct and indirect effects of lightning and ordnance must meet operational performance requirements after experiencing a nearby strike in an exposed condition and a direct strike in a stored condition. Further, ordnance is required to remain safe during and after experiencing a direct strike in an exposed condition. Specific lightning requirements can be found in Figures 1 and 2 and Table 7 of MIL-STD-464C.

Lightning requirements must be tailored for specific applications and the level of performance required may vary within a given system depending on the function in question. For example, aircraft will segregate functionality based on criticality where some functions/subsystems will only be required to survive a lightning strike, others will be required to per-

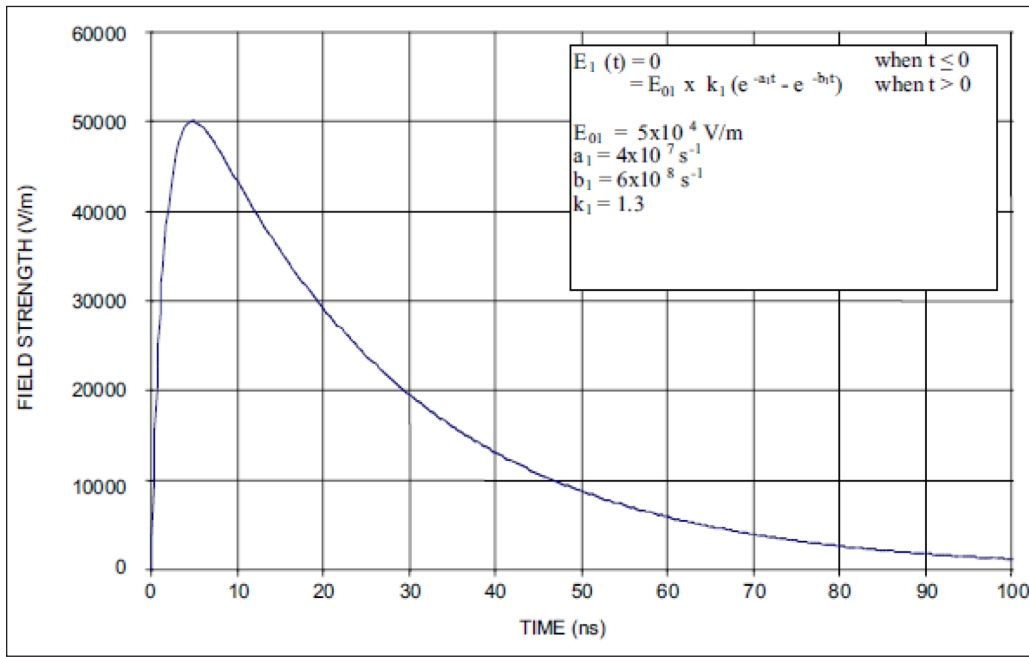

**FIGURE 1:** Unclassified EMP Free Field Waveform

form through the lightning strike. The development of composite airframes has resulted in complexities in lightning protection design and aircraft built with large amounts of graphite epoxy based structure carry higher currents than their metallic aircraft counterparts.

Internal currents on electrical conductors within fuel tanks can cause arcing and sparking that can potentially ignite fuel vapors if electrical bonding is not properly implemented. An important aspect in fuel vapor areas is that the current appears on all types of electrically conductive materials such as fuel tubes, hydraulic tubes, inerting lines, metal brackets, and conduits.

The importance of lightning effects has led to inclusion of limited lightning requirements now found in MIL-STD-461G, specifically test method CS117.

### Electromagnetic Pulse (EMP)

Similar to HPM, EMP is only required when specified by the procuring activity and is generally found in early stage acquisition documents. High-altitude EMP (HEMP) is generated by a nuclear burst above the atmosphere which produces coverage over large areas and is relevant to many military systems. The entire continental US area can be exposed to high-level fields with a few bursts.

The unclassified free field EMP waveform is shown in Figure 1. However, the true EMP requirement when imposed is contained in the classified HEMP environment of MIL-STD-2169.

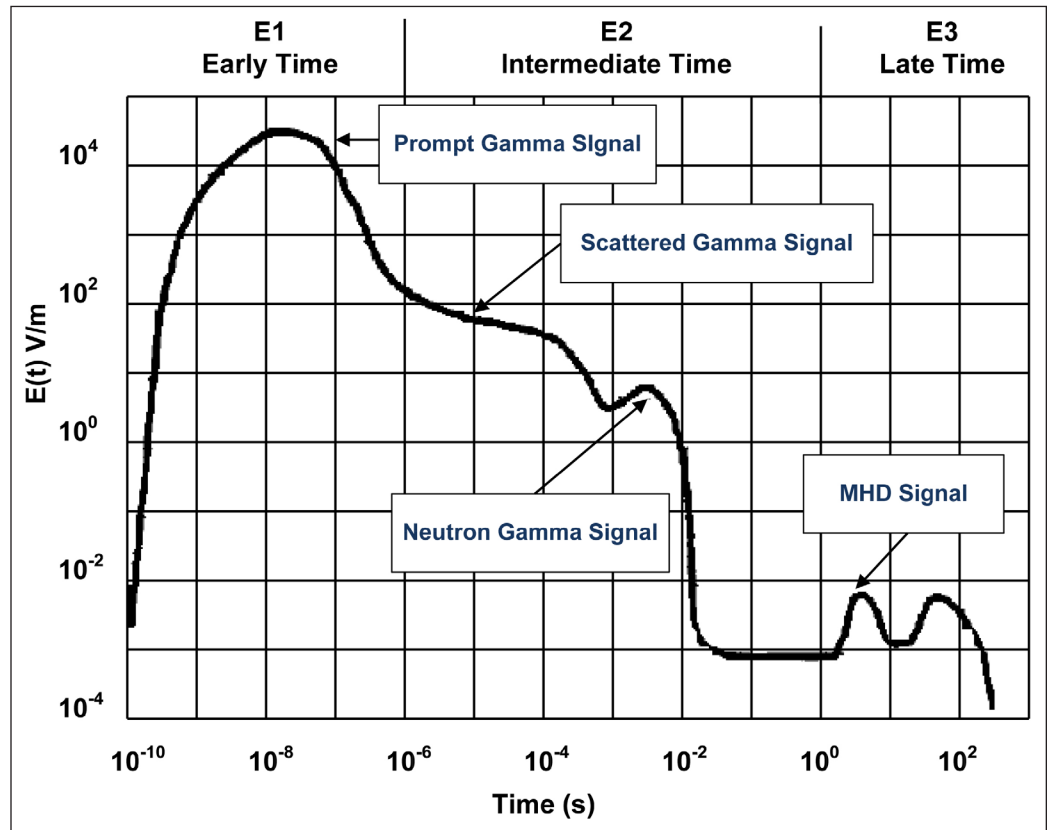

**FIGURE 2:** Unclassified Nominal HEMP Composite Environment (E1, E2, and E3)



MegaPhase®



## Our Warrior Cable® Comes With Its Own Set Of Armor

Some jobs are just too tough for ordinary RF cables. That's why our Warrior Cable features internally armored GrooveTube® technology – super flexible copper outer conductor tubing. The protective shielding enables the Warrior Cable to provide long-term repeatable performance in even the most extreme conditions.

It's ideal for use in electronic countermeasures, electronic warfare, and field-deployed communication systems ... or in commercial/ industrial situations where tough handling or demanding conditions exist.

No job is too tough for the MegaPhase Warrior Cable.

For more information, visit [MegaPhase.com](http://MegaPhase.com) or call us at (570) 424-8400.



**With the right connections,  
anything is possible.**



122 Banner Road, Stroudsburg, PA 18360-6433

Tel: 1-877-634-2742 | 570-424-8400

[Solutions@MegaPhase.com](mailto:Solutions@MegaPhase.com) | [www.MegaPhase.com](http://www.MegaPhase.com)

An unclassified composite waveform of the early-time (E1), mid-time (E2), and late-time (E3) HEMP environment is shown in Figure 2.

E1 contains strong in-band signals for coupling to MF, HF, VHF and some UHF receivers. E2a is a plane wave that couples well to long conductive lines, vertical antenna towers, and aircraft with trailing wire antennas and E2b couples well to long overhead and buried conductive lines and to extended VLF and LF antennas on submarines. E3 couples well to power and long communications lines including undersea cables. The waveform in Figure 9 only addresses the E1. The primary issues with EMP are temporary interruption of functionality, but damage is possible in certain cases. The frequency domain plot of the unclassified free field waveform indicates the primary areas of concern are below several hundred MHz.

Although HEMP is propagated as a plane wave, it is impossible to identify the specific orientation and aspect angle any system will be in during exposure to an EMP event, so the maximum field threat is applied.

### Subsystem EMI

The requirements on subsystems and equipment in MIL-STD-464C are primarily intended to minimize the risk that lower level components of the system/platform will result in EMI issues when integrated into the larger system/platform. Specifically, the requirements on subsystems and equipment are identified in documents such as MIL-STD-461G, and other commercial equipment level specifications such as RTCA DO-160. These requirements are used to provide reasonable confidence that a particular subsystem or equipment will function within designated design tolerances when operating in their intended EME and most commonly include conducted and radiate emissions and conducted and radiated susceptibility. It should be noted that MIL-STD-461G requirements are platform and application dependent and allowable emissions limits and susceptibility stimulus must be appropriate for the intended platform and application.

Non-Development Items (NDI) and Commercial Off the Shelf (COTS) are also addressed. The use of COTS equipment in military systems has grown exponentially over the last 10 years or more and represents one of the largest problems facing the US military E3 community. While there are advan-

tages in areas such as more rapid technological improvements, the reality is that COTS equipment is not generally designed to function in the extreme military EMEs. When installed in the system/platform, NDI and commercial items MUST comply with the system level E3 requirements. In most cases, COTS equipment has been qualified to commercial EMI/EMC requirements which do not have a direct correlation to MIL-STD-461G and access to and evaluation of commercial test data to ensure system/platform level compatibility is challenging. This mini guide contains a section devoted to MIL-STD-461G. Commercial standards rarely align with military requirements.

For subsystems and equipment intended to be installed aboard ships, DOD-STD-1399-70-1 is required to ensure compatibility with the known DC magnetic field EME aboard Navy ships. The requirement is based on ship degaussing systems and includes a 1600 A/m steady state field and a 1600 A/m – 0 A/m collapsing field.

### Electrostatic Discharge (ESD)

Issues associated with ESD are well documented. MIL-STD-464C provides guidance on ESD for vertical lift and in-flight refueling operations, precipitation static (p-static), ordnance subsystems and electrical and electronic subsystems.

A static charge can develop from p-static effects on any aircraft type. For aircraft designed for lifting cargo, accumulated charge can result in arcing between the cargo hook and the load or between the suspended cargo and earth. For aircraft involved in refueling operations, the tanker aircraft can be at one voltage potential and the aircraft to be refueled will be at a different potential. For both vertical lift and in-flight refueling operations, the requirement is 300 kV discharge with a simulated aircraft capacitance of 1000 pf, through a maximum of one (1) ohm resistance with a circuit inductance not to exceed 20  $\mu$ H.

Aircraft in flight encounter precipitation and dust during normal flight operations. The result is an electrostatic charge buildup on the structure. Since there is no direct, intentional electrical path to allow the charges to flow off the aircraft, special control mechanisms become necessary to dissipate the charge. When the accumulated charge develops a



high enough voltage with respect to the surrounding air, the air periodically breaks down resulting in sharp impulses which produce broadband radiated interference. MIL-STD-464C requires protection against charge accumulation of up to  $30 \mu\text{A}/\text{ft}^2$  ( $326 \mu\text{A}/\text{m}^2$ ).

Explosive subsystems are used for many purposes in military systems. With functions ranging from store ejection, escape systems, rocket motors, and warhead initiation. Voltages and discharge energies associated with ESD can inadvertently ignite or fire these devices. The ESD charge level is 25 kV. Due to the potentially severe consequences, a worst case model was chosen, discharging a 500 pF capacitor through a  $500 \Omega$  resistor with a circuit inductance not to exceed  $5 \mu\text{H}$ . In the case of Electrically Initiated Devices (EIDs), the discharges must be applied in both pin-to-pin and pin-to-case modes for both polarities.

Electrical and electronic subsystems contain sensitive electronic components that can be inadvertently damaged by human ESD during normal operations and maintenance activities. The ESD environment is specified as an 8kV (contact discharge) or 15kV (air discharge) electrostatic discharge. Discharging from a 150 pF capacitor through a  $330 \Omega$  resistor with a circuit inductance not to exceed  $5 \mu\text{H}$  to the electrical/electronic subsystem (such as connector shell (not pin), case, and handling points).

### **Electromagnetic Radiation Hazards (EMRADHAZ)**

High level electromagnetic fields have the potential for creating a number of hazards including Hazards of Electromagnetic Radiation to Personnel (HERP), Hazards of Electromagnetic Radiation to Fuel (HERF) and Hazards of Electromagnetic Radiation to Ordnance (HERO).

RF energy can be hazardous to personnel when energy is absorbed by biological tissue, it can cause heating of the tissue (microwave cooking effect) with subsequent tissue damage if temperatures are high enough. It can also be hazardous when there is high induced voltage on a metallic object, RF burns can result if contact is made by personnel; the results can be pain, visible skin damage, or involuntary reaction.

DOD INST 6055.11, in conjunction with IEEE C95.6-2002 and IEEE C95.1-2005, provides exposure limits to protect against established adverse effects to human health induced by exposure to RF electric, magnetic and electromagnetic fields over the frequency range of 0 Hz to 300 GHz. Previous versions of DOD INST 6055.11 specifically cited the restrictions. The latest version only points to the IEEE C95 series documents for actual limits.

The presence of high level RF fields in the vicinity of fueling operations can create a potential hazard for unintentional ignition. Fuel vapors can be ignited by an arc induced by a strong RF field. The fuel hazard criteria are usually based on peak power measurements while personnel hazard criteria are based on average power. The existence and extent of a fuel hazard are determined by comparing the actual RF power density to an established safety criterion. TO 31Z-10-4 and OP 3565 provide procedures for establishing safe separation distances from transmitters during fueling operations. JP-5 aircraft fuels aboard ships has decreased the HERF risk.

Ordnance items containing EIDs must be evaluated for HERO, for both direct RF induced actuation of the EID and inadvertent activation of an electrically powered firing circuit.

Ordnance HERO classifications include:

**HERO SAFE ORDNANCE** - Ordnance that has been analyzed/tested and is essentially immune to the effects of RF energy when exposed to the external EME.

**HERO SUSCEPTIBLE ORDNANCE** - Ordnance that has been analyzed/tested and is moderately affected by RF energy when exposed to the external EME.

**HERO UNSAFE/UNRELIABLE ORDNANCE** - Ordnance that has not been evaluated for HERO, any ordnance whose internal wiring is inadvertently exposed to the EME, e.g., tests or programming operations are being performed where additional electrical connections are made to the item during assembly/disassembly or when the item is in a disassembled condition and not in an all metal container or otherwise shielded.

Table 7 shows the HERO EME.

Frequency Range		Field Intensity (V/m-rms)			
		Unrestricted		Restricted**	
MHz	MHz	Peak	Average	Peak	Average
0.01	2	200	200	200	200
2	30	200	200	100	100
30	150	200	200	80	80
150	225	200	200	70	70
225	400	200	200	100	100
400	700	2200	410	450	100
700	790	700	410	270	270
790	1000	2600	490	1400	270
1000	2000	6100	600	2500	160
2000	2700	6000	500	490	160
2700	3600	27460*	2620*	2500	220
3600	4000	8600	280	1900	200
4000	5400	9200	660	650	200
5400	5900	9200	660	6200	240
5900	6000	9200	270	550	240
6000	7900	4100	400	4100	240
7900	8000	550	400	550	200
8000	8400	7500	400	1100	200
8400	8500	7500	400	1100	200
8500	11000	7500	910	2000	300
11000	14000	7500	680	3500	220
14000	18000	8700	680	8700	250
18000	50000	2900	580	2800	200

\* The EME levels in the table apply to ship launched ordnance that will traverse the main beam of systems in the 2700 to 3600 MHz frequency range on surface combatants. For all other ordnance, the unrestricted peak EME level is 12667 V/m and the unrestricted average level is 1533 V/m.

\*\* In some of the frequency ranges for the "Restricted Average" column, limiting the exposure of personnel through time averaging will be required to meet the requirements of 5.9.1 for personnel safety.

TABLE 7: Maximum External EME Levels for Ordnance

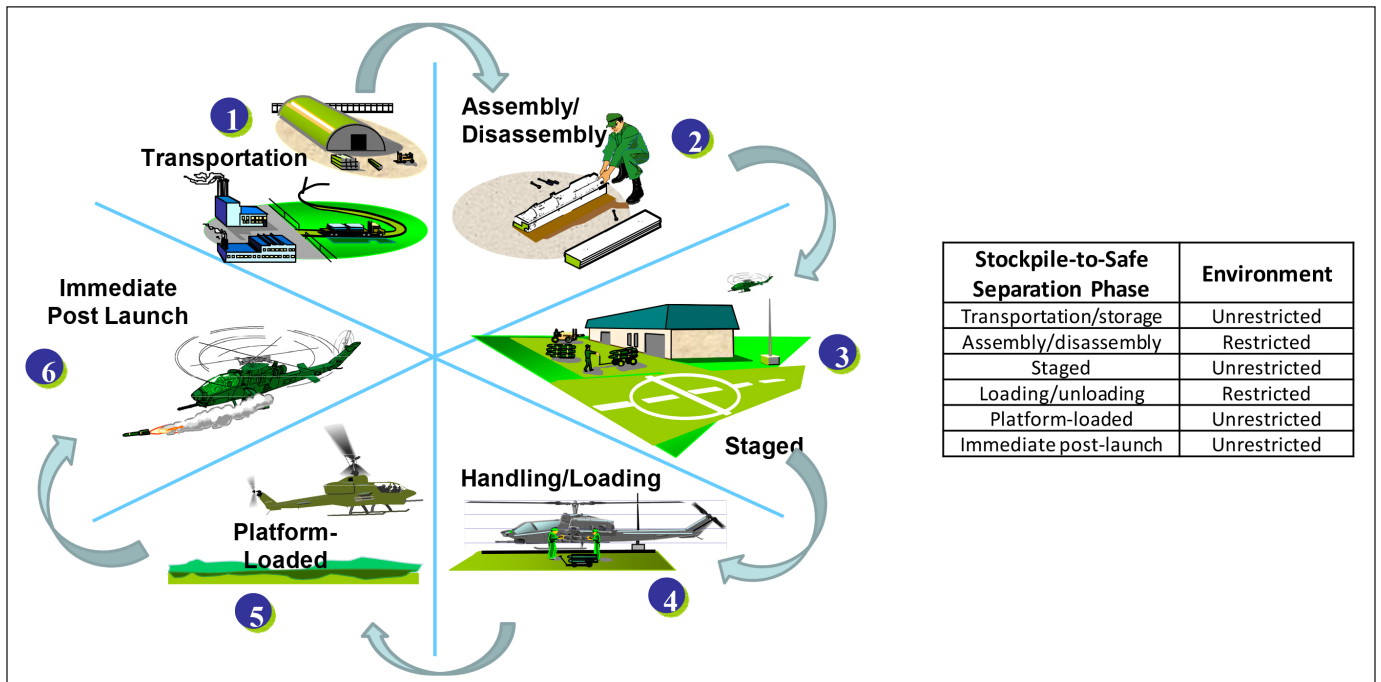

FIGURE 3: Stockpile-to-Safe Separation Sequence.



Table 7 includes levels for the unrestricted and restricted environments. The unrestricted environment represents the worst case levels to which the ordnance may be exposed. The restricted environment involves circumstances where personnel are directly interacting with the ordnance (assembly/disassembly, loading/unloading). Figure 3 illustrates the applicable unrestricted and restricted scenarios over the Stockpile-to-Safe Separation sequence.

In order to get a HERO classification of “HERO SAFE ORDNANCE” at the all-up round or appropriate assembly level, the ordnance must be evaluated against, and be in compliance with, the Table 9 of MIL-STD-464C. MIL-HDBK-240 provides guidance on test and analysis methodology.

### Lifecycle E3 Hardness

Over the course of a system lifecycle, it is imperative that E3 requirements and operational performance are met. Including following maintenance and repair activities. Corrosion control is critical and must be maintained, especially for shipboard installations. It is essential, therefore, that life-cycle considerations be included in the tradeoffs used to develop E3 protection. E3 hardening features should either be accessible and maintainable or should survive the design lifetime of the system without mandatory maintenance or inspection.

### Electrical Bonding

A major design aspect for meeting many E3 related requirements is electrical bonding. For systems using structure for power return currents, bonding provisions shall be provided for current return paths for the electrical power sources such that the total voltage drops between the point of regulation for the power system and the electrical loads are within the tolerances of the applicable power quality standard. Compliance shall be verified by test or analysis of electrical current paths, electrical current levels, and bonding impedance control levels. Specific guidance is provided for power current return paths, antenna installations, mechanical interfaces and shock, fault and ignitable vapor protection.

Power quality standards such as MIL-STD-704 and MIL-STD-1399-Section 300 provide tolerances for the allowable voltage drop between the point of regulation for the power system and the electrical loads or systems when using structure for power return currents. Space vehicle power systems gen-

erally prohibit the use of structure as power return and should use the requirements of MIL-STD-1541 as guidance.

Poor bonding designs in antenna installations often result in changes to the desired antenna patterns and degradation of the effective apertures. Additionally, poor antenna bonding has the potential for p-static and lightning performance implications.

Mechanical interface bonding requirements are specified as:

- a. 10 milliohms, or less, from the equipment enclosure to system structure, including the cumulative effect of all faying surface interfaces.
- b. 5 milliohms, or less, from cable shields to the equipment enclosure, including the cumulative effect of all connector and accessory interfaces.
- c. 2.5 milliohms, or less, across individual faying interfaces within the equipment, such as between subassemblies or sections.

### External Grounds

External grounds are necessary to provide fault current paths for protection of personnel from shock hazards and to dissipate static electricity for prevention of hazards to personnel, flammable vapors, ordnance and electronic hardware. Grounding jacks are required and the resistance between the mating plug and the system ground reference must be less than 1.0  $\Omega$ . Fuel nozzle, service and weapon grounding jacks are required.

### TEMPEST

Compromising emanations are unintentional intelligence bearing signals, which if intercepted and analyzed, would disclose national security information transmitted, received, handled, or otherwise processed by any classified information processing system. The requirement for TEMPEST is found in DoDD 5200.19 (classified). For Air Force aircraft, this requirement is generally applied to the communications subsystem only. The need to apply TEMPEST requirements is determined by the Certified TEMPEST Technical Authority (CTTA). The CTTA considers several vulnerability and threat factors to determine the residual risk to which the information is exposed. The CTTA then determines if countermeasures are required to reduce risk to an acceptable level and identifies the most cost effective approach to achieving imposed TEMPEST requirements.

Baseline requirements are contained in NSTISSAM TEMPEST/1-92, NSTISSAM TEMPEST/1-93, NSTISSAM TEMPEST/2-95, CNNS Advisory Memorandum TEMPEST 01-02, and Navy publication IA PUB-5239-31.

### System Radiated Emissions

Emissions Control (EMCON) limits unintentional electromagnetic radiated emissions for protection against detection by hostile forces. When tactical EMCON conditions are imposed, surface ships, submarines and airborne systems electromagnetic radiated emissions shall not exceed -110 dBm/m<sup>2</sup> (5.8 dB $\mu$ V/m) at one nautical mile or -105 dBm/m<sup>2</sup> (10.8 dB $\mu$ V/m) at one kilometer in any direction from the system over the frequency range of 500 kHz to 40 GHz when measured using the resolution bandwidths listed in Table 11 of MIL-STD-464C. Inter-system EMC addresses interactions with other collocated receiver systems.

### EM Spectrum Compatibility

Availability and use of the EM spectrum is a critical component of information dominance. The DoD Equipment Spectrum Certification (ESC) process requires that a DD Form 1494, be submitted through appropriate Service Frequency Management Office for approval. Instructions are delineated by each service for compliance with ESC regulations. An approved frequency allocation authorizes the development or procurement of spectrum-dependent systems in a defined frequency band or specified frequencies. The various stages of the ESC process, as delineated in MIL-STD-464C are defined below.

Stage 1 (Conceptual) approval is required for the Pre-Concept phase. A frequency allocation for Stage 1 must be requested (DD Form 1494) and approved prior to the releasing of funds for studies or assembling "proof-of-concept" test beds. The spectrum-dependent system purpose, planned frequency range and power, and any other planned or estimated details that are available on the item must be provided.

Stage 2 (Experimental) approval is required prior to contracting for the Concept Exploration and Definition phase. An approved frequency allocation for Stage 2 is required prior to the release of funds for building a radiating test model or obtaining an approved frequency assignment for experimental usage. Estimated and calculated data can be used for

nearly all of the blocks on DD Form 1494 when requesting a frequency allocation for Stage 2.

Stage 3 (Developmental) approval is required prior to contracting for the Engineering and Manufacturing Development phase. An approved frequency allocation for Stage 3 is required prior to the release of funds for developmental and operational testing. Frequency assignments must likewise be obtained prior to operation of spectrum dependent equipment. Calculated data is acceptable during Stage 3.

Stage 4 (Operational) approval is required prior to contracting for the Production and Deployment phase. Prior to contracting for production units, an approved frequency allocation for Stage 4 is mandatory. Measured data is mandatory for Stage 4. Calculated data is generally unacceptable. Commercial items normally require Stage 4 approval; however, if extensive modifications to the commercial item are planned, then Stage 3 may be appropriate.

Over the past several decades, significant military assets have been forfeited or lost due to failure to address E3 control and SS during the acquisition process, including the example at the beginning of this mini book.

### About the Author

Tony Keys is the President and Principal Consultant for EMC Analytical Services. Mr. Keys has over 20 years of experience in Electromagnetic Environmental Effects (E3) engineering. His experience covers a wide range of E3 specialty areas from a multitude of organizational aspects including E3 support contracting, DoD E3 service, and DoD system development. He can be reached at [tony.keys@emcanalyticalservices.com](mailto:tony.keys@emcanalyticalservices.com).





# Critical Moments call for Critical Products

## Coilcraft CPS has the battle-proven magnetics you need when the mission is on the line

Our critical-grade RF and power inductors are built to withstand the most punishing conditions imaginable, including extreme temperatures, thermal shock, G-forces, EMI and vibration.

- Tin-lead (Sn-Pb) terminations for the best possible board adhesion. RoHS terminations also available.
- Extended temperature ranges (-55°C to +200°C)
- Vibration testing to 80 G / shock testing to 1000 G

We also offer comprehensive product testing and validation services in accordance with MIL-STD-981 and EEE-INST-002, as well as custom screening to your electrical and physical specifications.

Learn more about how our battle-tested components will keep your mission on target. Call or visit us online today!

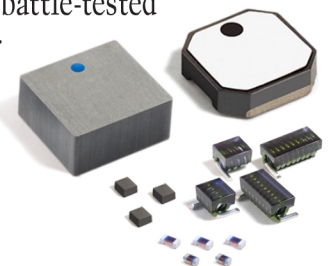

800.981.0363 847.639.6400 [www.coilcraft-cps.com](http://www.coilcraft-cps.com)

# Introduction to MIL-STD-461G

---

**TONY KEYS**

EMC Analytical Services

**KEN JAVOR**

EMC Compliance





Where MIL-STD-464C serves as a system/platform level set of requirements, MIL-STD-461G serves as an equipment/subsystem level set of requirements. Similar to MIL-STD-464C, MIL-STD-461G was developed as an “Interface Standard” to allow usage without a waiver. The overall structure of the two documents is also the same in that both have a contractual main body and a very informative non-contractual rationale and lessons-learned appendix. However, unlike MIL-STD-464C, MIL-STD-461G provides pass/fail criteria, limits, test levels and detailed procedures. The purpose of MIL-STD-461G is to control EMI characteristics of equipment/subsystems procured by the DoD to increase the likelihood of compatibility in its EME. It is not applicable for platforms/systems or modules/parts. Applicable items include enclosures no larger than an equipment rack, electrical interconnections that are discrete wiring harnesses between enclosures and electrical power derived from prime power sources. Requirements depend on equipment/subsystem type and use and may be tailored. It is important to note that passing MIL-STD-461G testing does not ensure platform level EMC and failing MIL-STD-464G testing does not necessarily mean a platform EMI problem.

As background, MIL-STD-461 is officially prepared by the US Air Force, but it is the product of a Tri-Service Working Group (TSWG) made up, not surprisingly, of representatives from the Army and Navy as well. In addition to Service members there are industry representatives.

Since 1993, MIL-STD-461 has been on a five-year review cycle, to ensure that it remains current and useful. This does not mean a new revision has to be released every five years; just that a review must be performed on that cycle. It would be entirely acceptable to simply reaffirm the old version with no changes. To date, that hasn't happened.

MIL-STD-461D and MIL-STD-462D released in 1993 remain the major “revolution” in military EMI standards, with evolutionary changes following. MIL-STD-461E combined MIL-STD-461 and MIL-STD-462 into a single standard, obsoleting MIL-STD-462 in 1999. MIL-STD-461F was released on 10 December 2007 and provided a number of changes from MIL-STD-461E, but the changes were minor in nature when compared to the changes between revisions D and E. MIL-STD-461G, released 11 December 2015, makes the most structural changes since that time, adding two new requirements (lightning indirect effects, CS117, and personnel electrostatic discharge, CS118) while eliminating the CS106 requirement that was added the last time around in MIL-STD-461F.

This guide will focus on MIL-STD-461G, but given the recent revision change and the fact that most programs are contractually under MIL-STD-461F, major differences between the two revisions will be highlighted as required. MIL-STD-461G imposes requirements in only four major areas for equipment and subsystems: Conducted Emissions (CE), Conducted Susceptibility (CS), Radiated Emissions (RE) and Radiated Susceptibility (RS) and are identified by a 1XX, to differentiate them from the earlier MIL-STD-461A/B/C requirements that were numbered XX. The complete listing of test methods is shown in Table 1. CS106 in blue text was required in MIL-STD-461F, but was eliminated from MIL-STD-461G. CS117 and CS118 in red text were added to MIL-STD-461G. The following is not intended to serve as an all-inclusive tutorial on MIL-STD-461G, but rather an overview to illustrate how MIL-STD-461G is employed as a tool by the DoD to support the warfighter.

Requirement	Description
CE101	Conducted Emissions, Audio Frequency Currents, Power Leads
CE102	Conducted Emissions, Radio Frequency Potentials, Power Leads
CE106	Conducted Emissions, Antenna Port
CS101	Conducted Susceptibility, Power Leads
CS103	Conducted Susceptibility, Antenna Port, Intermodulation
CS104	Conducted Susceptibility, Antenna Port, Rejection of Undesired Signals
CS105	Conducted Susceptibility, Antenna Port, Cross-Modulation
CS106	Conducted Susceptibility, Transients, Power Leads
CS109	Conducted Susceptibility, Structure Current
CS114	Conducted Susceptibility, Bulk Cable Injection
CS115	Conducted Susceptibility, Bulk Cable Injection, Impulse Excitation
CS116	Conducted Susceptibility, Damped Sinusoidal Transients, Cables and Power Leads
CS117	Conducted Susceptibility, Lightning Induced Transients, Cables and Power Leads
CS118	Conducted Susceptibility, Personnel Borne Electrostatic Discharge
RE101	Radiated Emissions, Magnetic Field
RE102	Radiated Emissions, Electric Field
RE103	Radiated Emissions, Antenna Spurious and Harmonic Outputs
RS101	Radiated Susceptibility, Magnetic Field
RS103	Radiated Susceptibility, Electric Field
RS105	Radiated Susceptibility, Transient Electromagnetic Field

Note: CS117 and CS118 were added for MIL-STD-461G (indicated in red).

Note: CS106 was a requirement in MIL-STD-461F, but has been removed from MIL-STD-461G (in blue).

**TABLE 1.** MIL-STD-461G Test Methods

The applicability of each test method is dependent on Service Branch and specific platform installation. Table 2 illustrates the applicability of each test method.

Equipment and Subsystems Installed In, On, or Launched From the Following Platforms or Installations	Requirement Applicability																		
	CE101	CE102	CE106	CS101	CS103	CS104	CS105	CS109	CS114	CS115	CS116	CS117	CS118	RE101	RE102	RE103	RS101	RS103	RS105
Surface Ships	A	A	L	A	S	L	S	L	A	S	A	L	S	A	A	L	L	A	L
Submarines	A	A	L	A	S	L	S	L	A	S	L	S	S	A	A	L	L	A	L
Aircraft, Army, Including Flight Line	A	A	L	A	S	S	S		A	A	A	L	A	A	A	L	A	A	L
Aircraft, Navy	L	A	L	A	S	S	S		A	A	A	L	A	L	A	L	L	A	L
Aircraft, Air Force		A	L	A	S	S	S		A	A	A	L	A		A	L		A	
Space Systems, Including Launch Vehicles		A	L	A	S	S	S		A	A	A	L			A	L		A	
Ground, Army		A	L	A	S	S	S		A	A	A	S	A		A	L	L	A	
Ground, Navy		A	L	A	S	S	S		A	A	A	S	A		A	L	L	A	L
Ground, Air Force		A	L	A	S	S	S		A	A	A		A		A	L		A	

A = Applicable (in green).

L = Limited as specified in the individual sections of MIL-STD-461G (in yellow).

S = Procuring activity must specify in procurement documentation (in red).

**TABLE 2.** MIL-STD-461G Requirements Matrix



# ULTRA HIGH SPEED

VISIT US AT  
BOOTH

**#722**

IEEE EMC SYMPOSIUM  
OTTAWA CANADA  
2016

**TDEMI<sup>®</sup> X – 64 000 TIMES FASTER THAN  
CONVENTIONAL EMI RECEIVERS  
FROM DC - 40 GHz**



**645**<sup>MHz</sup>

**REAL-TIME BANDWIDTH  
TDEMI<sup>®</sup> TECHNOLOGY**

Fully gapless real-time analysis / 645 MHz Quasi-Peak in real-time / 6 dB bandwidths  
CISPR, MIL461 & DO160 / Intermittent disturbances / Single events and transient signals /  
Easy operation via Zoom, Pan, and Marker functions / Full compliance testing in real-time

**6**<sup>GHz</sup>

**REAL-TIME SCANNING  
TDEMI<sup>®</sup> TECHNOLOGY**

Full Compliance Testing / Real-time Scanning of several GHz / 3 dB Resolution Bandwidth  
1 Hz – 14 MHz IFs / 6 dB Bandwidths CISPR, MIL461 & DO160 / Wide band signal analysis/  
Excellent accuracy and ultra high-speed / Easy operation via Zoom and Pan functions

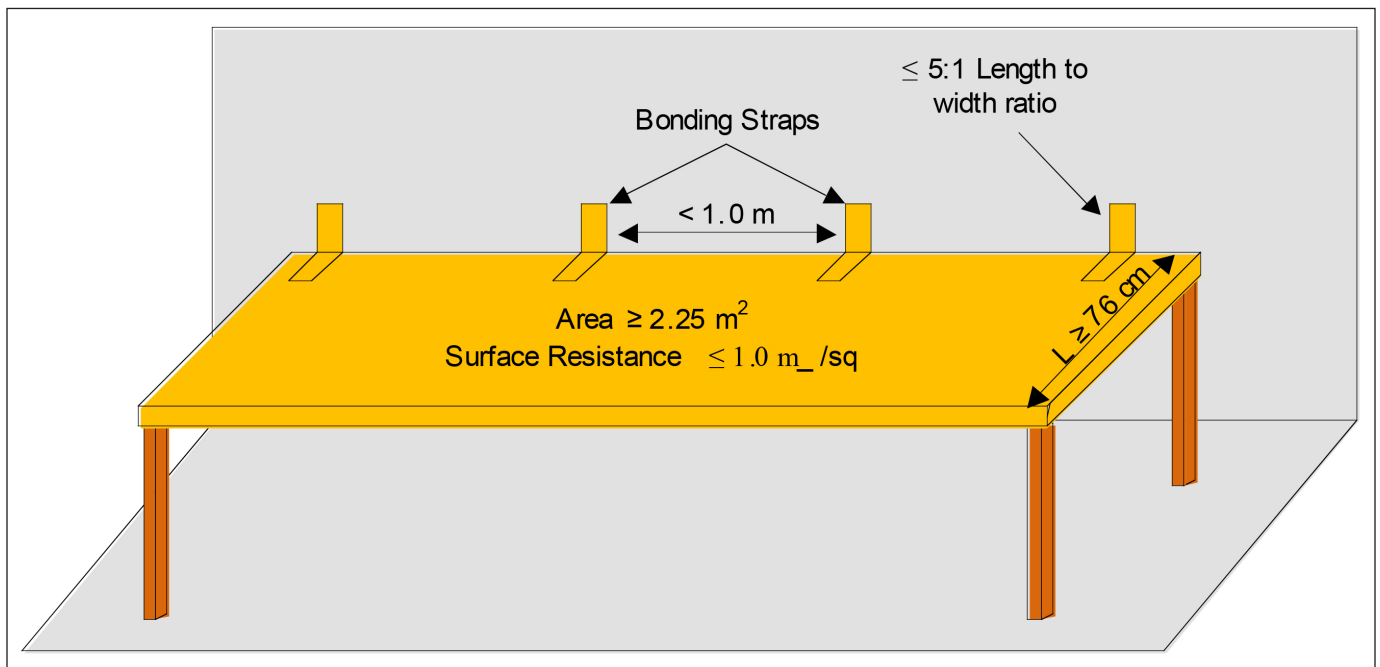

**FIGURE 1:** Test Ground Plane Configuration

MIL-STD-461G provides a set of general interface and verification requirements. The general interface requirements include motherhood style guidance on joint procurements, self-compatibility, non-developmental items (NDI), Government Furnished Equipment (GFE), switching transients and interchangeable modular equipment. They also include specific requirements on minimizing the use of line-to-ground filters for EMI control in Navy systems. The general verification requirements include detailed information for verification testing on topics including; measurement tolerances, shielded enclosures, ambient electromagnetic level, ground planes, power source impedance, general test precautions, EUT test configurations and operations, and the use and calibration of measurement equipment.

Measurement tolerances are specified for distance ( $\pm 5\%$ ), frequency ( $\pm 2\%$ ), amplitude of the measurement receiver ( $\pm 2$  dB), time waveforms ( $\pm 5\%$ ), resistors ( $\pm 5\%$ ), capacitors ( $\pm 20\%$ ) and the overall amplitude of the complete measurement system ( $\pm 3$  dB). Shielded enclosures are normally required for MIL-STD-461G testing with RF absorber material placed above, behind, and on both sides of the EUT as well as behind the transmitting or receiving antenna. The RF absorber material is required to have a minimum absorption of 6 dB from 80 MHz to 250 MHz and 10 dB above 250 MHz. Controlling the ambient environment during testing is critical.

The ambient electromagnetic level measured with the EUT de-energized and all auxiliary equipment turned on must be at least 6 dB below the allowable specified limits when the tests are performed in a shielded enclosure. Ambient conducted levels on power leads should be measured with the leads disconnected from the EUT and connected to a resistive load, which draws the same rated current as the EUT. Testing must be performed with ground planes that simulate the actual installation if it is known. In cases where the specific installation is not known, or there will be various installations employed, then a metallic ground plane is used. For cases where the EUT does not employ a ground plane when installed, testing is performed on a non-conductive table. In some cases, conductive composite ground planes are used in the installed configuration. In these cases, the surface resistivity of the typical installation is used. Figure 1 summarizes the ground plane requirements delineated in MIL-STD-461G.

The impedance of power sources providing primary input power to the EUT is controlled by specific (50  $\mu$ H) Line Impedance Stabilization Networks (LISNs) for all measurement procedures. There are specific cases for CE101 and CE102, where the use of a 5  $\mu$ H LISNs may be acceptable, but for the vast majority of applications, the 50  $\mu$ H LISN is used. The specified LISN parameters are shown in Figure 2.

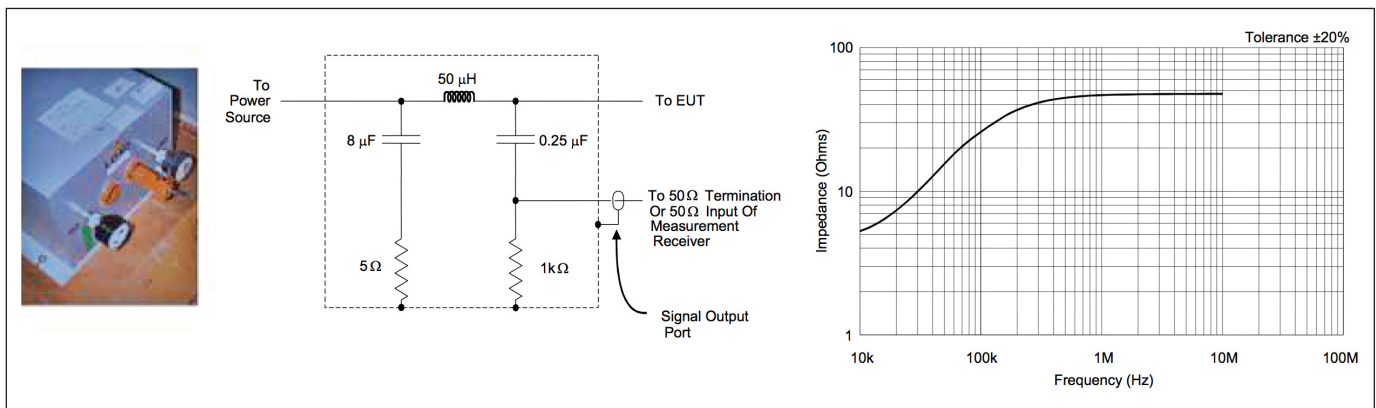

**FIGURE 2:** MIL-STD-461G 50  $\mu$ H LISN

While it was always understood that LISNs must have an excellent RF bond to the ground plane for proper operation, it was not specifically stated until the MIL-STD-461G release.

One of the prime factors in MIL-STD-461G radiated (and conducted for that matter) test results is the arrangement and treatment of the electrical interfaces. Electrical cable assemblies are required to simulate actual installation and usage. The cable design and construction must be production representative (preferably actual production cables!). The cables used for testing must be fabricated identical to actual cables in terms of shielding and shield termination technique, wire size, twisting, etc. Shielded cables or shielded leads are only allowed if they have been specified in installation requirements. Input (primary) power leads, returns, and wire grounds shall not be shielded. Cables shall be checked against installation requirements to verify proper construction.

Individual leads are to be grouped into cables in the same manner as in the installation configuration with the lengths identical to the actual platform installation. In cases of cables longer than 10 meters, at least 10 meters must be included. The first 2 meters of cable length (except for cables less than 2 meters in the actual installation) must be run parallel to the front boundary of the setup. The remaining lengths

are routed to the back of the setup and placed in a zigzagged arrangement, minimizing cable overlap or crossing. Individual cables are required to be separated by 2 cm measured from each other, but this can become very difficult to achieve for systems employing a significant number of cables. The cable closest to the front boundary must be placed 10 cm from the front edge of the ground plane MIL-STD-461G now stipulates that the entire length of the cable, not just the two meters exposed to the antenna, be supported 5 cm above the ground plane using “non-conductive material such as wood or foam.” MIL-STD-4G1G addresses cable routing for floor standing units and requires that cables are routed from the top of the EUT then routed down to the bench ground plane with 2 meters run parallel to the front edge of the boundary. If the cables are routed from the bottom, then the cables must be routed up to the bench ground plane and then 2 meters run parallel to the front edge of the boundary.

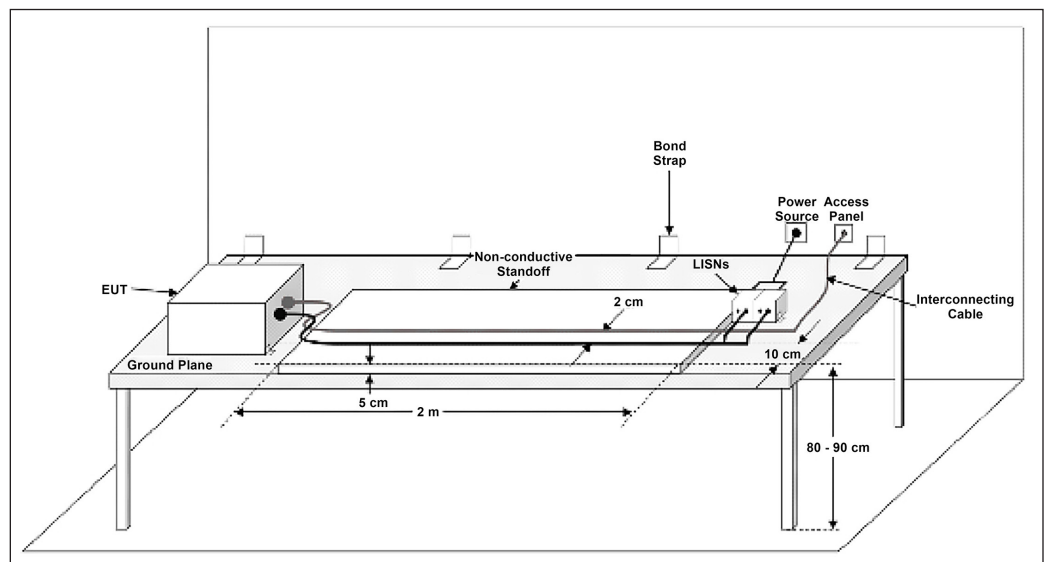

**FIGURE 3:** Ground Plane Mounted EUT Cable Routing



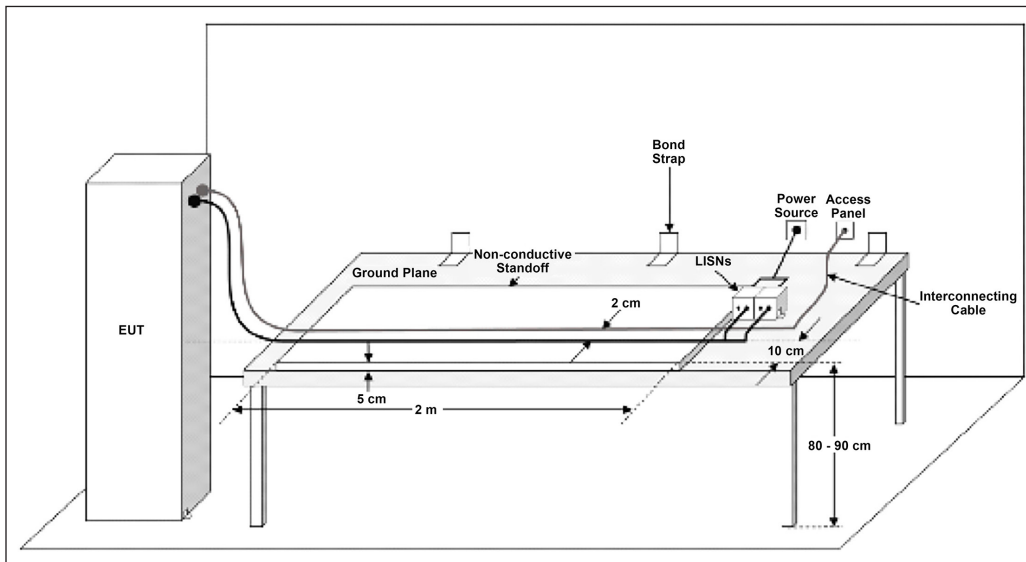

FIGURE 4: Floor Mounted EUT Cable Routing

Power leads are treated in a similar manner with regards to routing, but after the 2 meter exposed length, the power lead to LISN connection length must be as short as possible with a total length not to exceed 2.5 meters, except in cases of large EUTs. Cable routing requirements can be seen in Figures 3 and 4.

The operation of the EUT during testing should represent the mode producing the maximum emissions expected during emissions testing and mode which is most susceptible during susceptibility testing. This is very easy to state and attempt to require, but the reality is that engineering judgment is often

needed to balance cost and technical aspects. In most cases, this will require a joint effort between systems engineers and EMI engineers to resolve, depending on the complexity and number of modes of operation.

For emission measurements, a peak detector is required and measurement parameters are shown in Table 3 with the changes for MIL-STD-461G highlighted in red. The use of FFT or time domain receivers, a new technology since the last release of the standard, is specifically addressed and Table 3 below shows parameters for the use of such machines.

Frequency Range	6 dB BW	Minimum Dwell Time		Minimum Measurement Time for Analog Measurement Receiver
		Stepped Receiver	FFT Receiver	
30 Hz – 1 kHz	10 Hz	0.15 sec	<b>1</b>	0.015 sec/Hz
1 kHz – 10 kHz	100 Hz	0.015 sec	<b>1</b>	0.15 sec/kHz
10 kHz - 150 kHz	1 kHz	0.015 sec	<b>1</b>	0.015 sec/kHz
<b>150 kHz - 10 MHz</b>	<b>10 kHz</b>	<b>0.015 sec</b>	<b>1</b>	<b>1.5 sec/MHz</b>
<b>10 MHz – 30 MHz</b>	<b>10 kHz</b>	<b>0.015 sec</b>	<b>0.15</b>	<b>1.5 sec/MHz</b>
30 MHz - 1 GHz	100 kHz	0.015 sec	<b>0.15</b>	0.15 sec/MHz
Above 1 GHz	1 MHz	0.015 sec	<b>0.015</b>	15 sec/GHz

TABLE 3: Emissions Bandwidth and Measurement Times

Frequency Range	Analog Scans Maximum Scan Rates	Stepped Scans Maximum Step Size
30 Hz – 1 MHz	0.0333 $f_0$ /sec	0.05 $f_0$
1 MHz – 30 MHz	0.00667 $f_0$ /sec	0.01 $f_0$
30 MHz – 1 GHz	0.00333 $f_0$ /sec	0.005 $f_0$
1 GHz – 40 GHz	0.00167 $f_0$ /sec	0.0025 $f_0$

TABLE 4: Susceptibility Scanning

FFT receivers differ from traditional EMI receivers. Traditional EMI receivers tune to a particular frequency, dwell for a time, then step to the next frequency. FFT receivers look at very large bands and use FFT algorithms to display signals as they would appear if measured traditionally. FFT receivers are much faster than traditional receivers. FFT operation must be in accordance with ANSI C63.2 and Table II parameters must be directly addressable, not as FFT quantities such as window type and percentage overlap. The appendix of MIL-STD-461G provides an excellent overview of the use of FFT receivers.

Specific guidance is provided for susceptibility testing on measurement scan rates, sweep times, dwell time and step size based on frequency range and is shown in Table III or 4.

The modulation of the CS114 and RS103 test stimulus is pulse modulated (on/off ratio of 40 dB

minimum) at a 1 kHz rate with a 50% duty cycle. The dwell time of the susceptibility signal is often challenging. MIL-STD-461G requires a dwell time of 3 seconds or EUT response time, whichever is greater. However, when multiple modes of operation are required to be evaluated and the EUT response times are long, this requirement can be a larger cost and schedule driver due to the inherent length of RS103 and CS114 testing in general. This is another area where systems engineering and EMI engineering should work together for the best solution.

MIL-STD-461G includes 19 specific requirements and attendant test methods. Figure 9 provides a generic military system with the applicability for each requirement. An overview of each requirement/method follows. It should be noted that each and every test method contains very specific details and nuances and the appendix of MIL-STD-461G provides clarification on the requirements and applica-

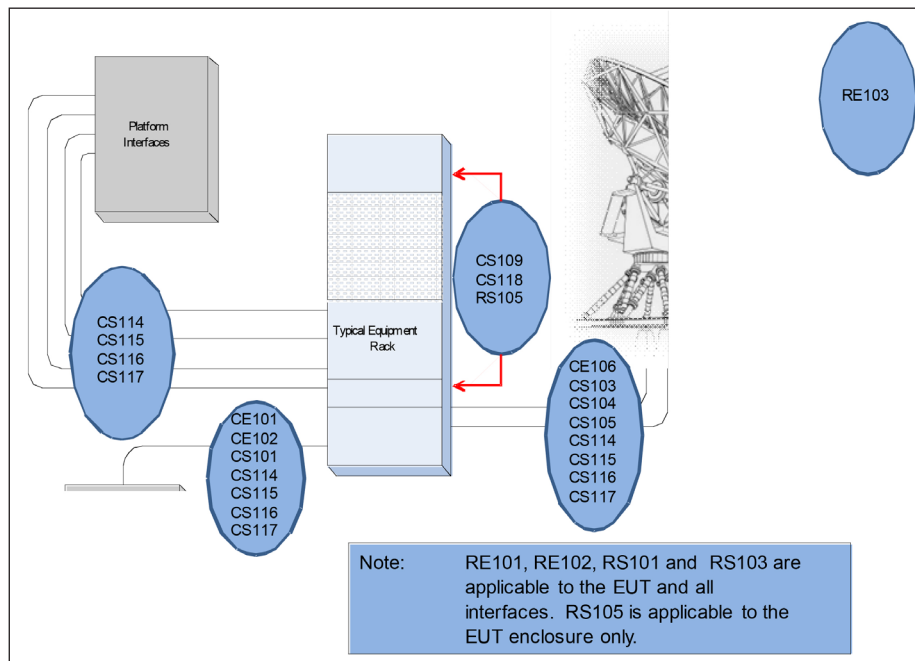

FIGURE 9: Test Method Applicability



# NEXT GENERATION POWER AMPLIFIERS

## In Situ EMC Testing?

Empower is bringing the element of portability to high power RF amplifiers with small size that allows these amplifiers to be conveniently shipped for offsite testing and moved around as needed within your test environment

- 40 to 70% smaller and lighter as a result of patented architecture
- Rugged design ships reliably, over and over again



- ▷ Selectable Output Power Control
- ▷ Selectable Operating Modes
- ▷ Selectable Input/Output Detectors
- ▷ Upgradable to Future Modulation Standards
- ▷ LXI Optional
- ▷ Built in Web Server

Click on the product for more info



2 kW in 8U chassis	SKU 2162	20 - 1000 MHz	1 kW	R5U
1 kW in 5U chassis	SKU 2185	960-1215 MHz	10 kW	R9U
500 W in 3U chassis	SKU 2180	1 - 2.5 GHz	2 kW	R8U
	SKU 2187	1 - 3 GHz	500 W	R5U
	SKU 2170	1 - 3 GHz	1 kW	R5U
	SKU 2186	2 - 6 GHz	150 W	R3U
	SKU 2179	2 - 6 GHz	250 W	R4U

1(310)412-8100  
www.EmpowerRF.com

 **EMPOWER**  
RF SYSTEMS, INC.



bility and detailed information on the test approach and procedures which are outside the scope of this mini guide.

### **CE101 Conducted Emissions, Audio Frequency Currents, Power Leads**

CE101 is applicable from 30 Hz to 10 kHz for leads that obtain power from sources that are not part of the EUT. There is no requirement on output leads from power sources. Emission levels are determined by measuring the current present on each power lead. For surface ships and submarines, the intent is to control the effects of conducted emissions peculiar to the shipboard power distribution system. For Army aircraft, the concern is to ensure that the EUT does not corrupt the power quality on platform power buses. For Navy aircraft, CE101 is only applicable for installations using anti-submarine warfare (ASW) equipment, which operate between 30 Hz and 10 kHz. The specific limits are based on application, input voltage, frequency, power and current. One of the more common problem areas is rectifier noise at power line harmonic frequencies.

Changes made for MIL-STD-461G include clarification of the applicability to Navy aircraft in the following text: For equipment intended to be installed on Navy aircraft, this requirement is applicable only if the platform contains Anti-Submarine Warfare (ASW) equipment, which operate between 30 Hz and 10 kHz, such as Acoustic (Sonobouy) Receivers or Magnetic Anomaly Detectors (MAD). Test changes include specific measurement system check frequencies at 1.1 kHz, 3 kHz and 9.9 kHz instead of 1.0 kHz, 3 kHz and 10.0 kHz and a change to Figure CE101-1 which now specifies limits for both surface ship and submarine DC applications.

### **CE102 Conducted Emissions, Radio Frequency Potentials, Power Leads**

CE102 is applicable from 10 kHz to 10 MHz for leads that obtain power from sources that are not part of the EUT. There is no requirement on output leads from power sources. The lower frequency portion is to ensure EUT does not corrupt the power quality (allowable voltage distortion) on platform power buses. Voltage distortion is the basis for power quality so CE102 limit is in terms of voltage. The emission levels are determined by measuring voltage present at the output port of the LISN. Unlike CE101, CE102 limits are based on voltage. The basic limit is relaxed for increasing source voltages, but independent of current. Failure to meet the CE102 lim-

its can often be traced to switching regulators and their harmonics.

The major change to CE102 in MIL-STD-461G is verifying the LISN impedance at frequencies where it isn't 50  $\Omega$ , by recording how hard the signal generator must be driven at 10 and 100 kHz during the measurement system integrity test.

### **CE106 Conducted Emissions, Antenna Port**

CE106 is applicable from as low as 10 kHz to as high as 40 GHz (depending on the operating frequency) for antenna terminals of transmitters, receivers, and amplifiers and is designed to protect receivers on and off the platform from being degraded by antenna radiation from the EUT. CE106 is not applicable for permanently mounted antennas. The upper test frequency requirement has been modified from MIL-STD-461F such that systems with the frequencies < 1 GHz, the upper frequency limit will be 20 times the highest frequency or 18 GHz whichever is greater. For systems with frequencies  $\geq$  1 GHz, the upper frequency limit will be 10 times the highest frequency or 40 GHz whichever is less. There is also a Navy shipboard specific frequency exclusion for transmitters with peak transmitter power greater than 1 kW. The standard 5% frequency exclusion will be increased by an additional 0.1% of the fundamental frequency for each dB above 1 kW of peak power.

The limits for receivers and transmitters and amplifiers in standby mode are 34 dB $\mu$ V. For transmitters and amplifiers in transmit mode, harmonics, except the second and third, and all other spurious emissions shall be at least 80 dB down from the level at the fundamental. The second and third harmonics shall be suppressed to a level of -20 dBm or 80 dB below the fundamental, whichever requires less suppression. For Navy shipboard applications, the second and third harmonics will be suppressed to a level of -20 dBm and all other harmonics and spurious emissions shall be suppressed to -40 dBm, except if the duty cycle of the emissions are less than 0.2%, then the limit may be relaxed to 0 dBm.

CE106 limits for transmit mode operation may disagree with the system performance specification. Unfortunately, in many procurements, the transmitter performance specifications are developed independent of the CE106 requirements and suppression to meet requirements can result in significant design penalties if not identified early enough in the program.

Changes made to Mil-STD-461G include specific guidance given for Navy shipboard applications with peak transmitter power greater than 1 kW and the previously mentioned frequency exclusion. The upper test frequency is modified. For systems with intentional frequencies < 1 GHz, the upper test frequency is 20 times the highest intentional frequency or 18 GHz whichever is greater and for systems with intentional frequencies  $\geq$  1 GHz, the upper test frequency is 10 times the highest intentional frequency or 40 GHz whichever is less. The Navy shipboard applications limits are modified such that the 2nd and 3rd harmonics will be suppressed to a level of -20 dBm and all other harmonics and spurious emissions shall be suppressed to -40 dBm, except if the duty cycle of the emissions are less than 0.2%, then the limit may be relaxed to 0 dBm.

### **CS101 Conducted Susceptibility, Power Leads**

CS101 is applicable from 30 Hz to 150 kHz for equipment and subsystem AC and DC power input leads. For DC powered equipment, CS101 is required over the entire 30 Hz to 150 kHz range. For AC powered equipment, CS101 is only required from the second harmonic of the equipment power frequency (120 Hz for 60 Hz equipment) to 150 kHz. In general, CS101 is not required for AC powered equipment when the current draw is greater than 30 amps per phase. The exception is when the equipment operates at 150 kHz or less and has an operating sensitivity of 1  $\mu$ V or better.

The intent is to ensure that performance is not degraded from ripple voltages on power source waveforms. Two test voltage levels are defined. One for equipment operating at input voltages greater 28 Volts and one for equipment operating at 28 Volts and below. The requirement is also met when the power source is adjusted to dissipate the power level shown on Figure CS101-2 of MIL-STD-461G in a 0.5  $\Omega$  load and the EUT is not susceptible.

Changes in MIL-STD-461G for CS101 include reducing applicability from a maximum load current of 100 Amps per phase to  $\leq$  30 Amps per phase, unless the system has an operating frequency 150 kHz or less and an operating sensitivity of 1  $\mu$ V or better (such as 0.5  $\mu$ V). Another change is allowing the use of Power Line Ripple Detectors (PRDs) to measure ripple induced on an AC power line in the frequency domain, which is very difficult to monitor in the time domain. The PRD functions as an interface between the power line and the 50  $\Omega$  input of a spectrum an-

alyzer or EMI receiver, allowing the measurement to be made in the frequency domain so that the ripple component can be seen entirely separately from the power line frequency.

### **CS103, CS104 and CS105 Conducted Susceptibility, Antenna Port, Intermodulation, Rejection of Undesired Signals and Cross-Modulation**

This series of receiver front-end tests include test methods for Intermodulation (CS103), Rejection of Undesired Signals (CS104) and Cross Modulation (CS105). They were designed for traditional tunable super-heterodyne type radio receivers. Due to the wide diversity of radio frequency subsystem designs being developed, the applicability of this type of requirement and appropriate limits need to be determined for each procurement. Also, requirements need to be specified that are consistent with the signal processing characteristics of the subsystem and the particular test procedures to be used to verify the requirement. These tests are particularly difficult to perform on modern channelized digital receiving systems and require a coordinated effort between systems engineering and EMI engineering. The reality of these tests is that they are most often used and perhaps best performed as characterization tests and not true qualification tests. There is very little guidance provided in MIL-STD-461G except for the original super-heterodyne type radio.

The intent of CS103 is to control the response of antenna connected receiving subsystems to in-band intermodulation products of two signals outside of the intentional passband of the subsystem. CS103 is most applicable to fixed frequency, tunable, super-heterodyne receivers.

The intent of CS104 is to control response of antenna connected receiving subsystems to signals outside the intentional passband of the subsystem. CS104 is most applicable to fixed frequency, tunable, super-heterodyne receivers. CS104 has been used to characterize performance related to the EME tables defined in MIL-STD-464 for systems where the antenna characteristics were well-defined and direct injection was feasible.

The intent of CS105 is to control the response of antenna connected receiving subsystems to modulation being transferred from an out-of-band signal to an in-band signal. CS105 should be considered only for receivers, transceivers, amplifiers, and the

like, which extract information from the amplitude modulation of a carrier.

### **CS109 Conducted Susceptibility, Structure Current**

CS109 is a highly specialized test applicable from 60 Hz to 100 kHz for very sensitive Navy shipboard equipment (1  $\mu$ V or better) such as tuned receivers operating over the frequency range of the test. Handheld equipment is exempt from CS109. The intent is to ensure that equipment does not respond to magnetic fields caused by currents flowing in platform structure. The limit is derived from operational problems due to current conducted on equipment cabinets and laboratory measurements of response characteristics of selected receivers.

### **CS114 Conducted Susceptibility, Bulk Cable Injection**

CS114 is applicable from 10 kHz to 200 MHz for all electrical cables interfacing with the EUT enclosures. There is also a common mode test applicable from 4 kHz to 1 MHz for shipboard and submarine installations with a test level of 77 dB $\mu$ A for complete power cables. Multiple test levels are imposed based on application. The concept is to simulate currents developed on platform cabling from electromagnetic fields generated by antenna transmissions both on and off the platform. CS114 is not applicable for coaxial cables to antenna ports of antenna-connected receivers except for surface ships and submarines. Similar to CS101, protection against over-testing is accomplished by limiting both injected current and potential. Under MIL-STD-461D and G, the requirement is also met if the EUT is not susceptible at forward power levels sensed by the directional coupler that are below those determined during calibration provided that the actual current induced in the cable under test is Curve 5 = 115 dB $\mu$ A, Curve 4 = 103 dB $\mu$ A, Curve 3 = 95 dB $\mu$ A, Curve 2 = 89 dB $\mu$ A and Curve 1 = 83 dB $\mu$ A across the frequency range. Due to impedance variations in the cable under test, the current injected may exceed the calibrated levels.

MIL-STD-461G introduces the requirement to insert a current probe and its fixture during the forward power pre-calibration in order to verify that the current probe's transfer impedance is properly taken into account by the measurement software, and that the current probe is functioning properly.

### **CS115 Conducted Susceptibility, Bulk Cable Injection, Impulse Excitation**

CS115 is applicable to all electrical cables interfacing with EUT enclosures. The primary concern is to protect equipment from fast rise and fall time transients that may be present due to platform switching operations and external transient environments such as lightning and electromagnetic pulse. CS115 replaces "chattering relay" type requirements (RS06 in MIL-STD-461C). The excitation waveform from the generator is a trapezoidal pulse and a single pulse type is required for all applications. The pulse has a 2 ns rise time which is consistent with waveforms created by inductive devices interrupted by switching actions and the 30 ns pulse width standardizes each pulse energy and separates the rise and fall portions of the pulse so that each act independently. The 5 ampere amplitude covers most induced levels observed during aircraft testing. The 30 Hz pulse rate ensures that a sufficient number of pulses are applied to increase confidence that the EUT will satisfactorily operate.

### **CS116 Conducted Susceptibility, Damped Sinusoidal Transients, Cables and Power Leads**

CS116 is applicable to electrical cables interfacing with each EUT enclosure and also on each power lead. The concept is to simulate electrical current and voltage waveforms occurring in platforms from excitation of natural resonances with a control damped sine waveform. Switching transients within the platform can also result in similar waveforms. At a minimum, testing is performed at 0.01 MHz (0.1 Amp peak), 0.1 MHz (1 Amp peak), 1 MHz (10 Amp peak), 10 MHz (10 Amp peak), 30 MHz (10 Amp peak), and 100 MHz (3 Amp peak).

Additionally, if there are other frequencies known to be critical to the equipment installation, such as platform resonances, testing should also be performed at those frequencies. The pulse repetition rate is not greater than one pulse per second and no less than one pulse every two seconds and is applied for a period of five minutes.

### **CS117 Conducted Susceptibility, Lightning Induced Transients, Cables and Power Leads**

CS117 is one of two new test methods added to MIL-STD-461G. CS117 is applicable to safety-critical equipment interfacing cables and also on each



power lead. Applicability for surface ship equipment is limited to equipment located above deck or which includes interconnecting cables, which are routed above deck. The concept is to address the equipment-level indirect effects of lightning as outlined in MIL-STD-464 and it is not intended to address direct effects or nearby lightning strikes. CS117 was borrowed from RTCA/DO-160 section 22, but many aspects of section 22 were left out of CS117. Two important simplifications are no pin testing, and just two levels, internal and external, mapping from RTCA/DO-160 section 22 levels 3 and 4, respectively. CS117 contains six waveforms borrowed from section 22. CS117 contains no separate table for a single stroke application. Instead, the single stroke levels of section 22 Table 22-3 have been incorporated into the multiple stroke Table VII of CS117. Table 22-3 levels 3 and 4 become the first stroke of the multiple stroke requirements in CS117 Table VII. Level 3 maps to internal, and level 4 maps to external. Subsequent strokes in CS117 Table VII are from section 22 Table 22-4, except that for Waveforms 4/5A, there was some mixing and matching from levels under Waveform 4/1 in section 22 Table 22-4.

Multiple bursts in the same CS117 Table VII are exactly the same as section 22 Table 22-5 levels 3 & 4, again mapping to internal and external installations, respectively.

### **CS118 Conducted Susceptibility, Personnel Borne Electrostatic Discharge**

CS118 is the other new test method added to MIL-STD-461G. CS118 is applicable to electrical, electronic, and electromechanical subsystems and equipment that have a man-machine interface. It should be noted that CS118 is not applicable to ordnance items. The concept is to simulate ESD caused by human contact and test points are chosen based on most likely human contact locations. Multiple test locations based on points and surfaces which are easily accessible to operators during normal operations. Typical test points would be keyboard areas, switches, knobs, indicators, and connector shells as well as on each surface of the EUT. The limit and method is borrowed from RTCA/DO-160 Section 25 and IEC 61000-4-2. CS118 requires the EUT to be electrically bonded in accordance with the product installation requirements. Limits are 8 kV for contact, 15 kV for air discharge. Contact discharge is the preferred method unless the test item has nonconductive surfaces requiring an air discharge approach. Air discharges are performed not only at the 15 kV

limit, as per RTCA/DO-160 section 25, but also at 2, 4, and 8 kV.

### **RE101 Radiated Emissions, Magnetic Field**

RE101 is applicable from 30 Hz to 100 kHz and is used to identify radiated emissions from equipment and subsystem enclosures, including electrical cable interfaces. For Navy aircraft, this requirement is only applicable for ASW capability operating between 30 Hz and 10 kHz.

RE101 is a specialized requirement, intended to control magnetic fields for applications where equipment is present in the installation, which is potentially sensitive to magnetic induction at lower frequencies. Applicable for equipment intended for Navy ships and submarines, Navy ASW, or Army aircraft. RE101 and RS101 are complimentary, imposed to control magnetic EMI to sensitive low frequency (LF) equipment. The Navy is concerned with the potential effects to LF, VLF, ELF and acoustic and communication systems and sensors with nano-volt sensitivities. The Army is concerned with potential effects to engine, flight, and weapon turret control systems and sensors with millivolt sensitivities. Limits are based on specific service applications with different limits for Navy and Army equipment. Common RE101 failures include equipment containing CRT yokes, transformers and switching power supplies.

Changes to MIL-STD-41G for RE101 include clarification for Navy aircraft applicability, specifically "Aircraft with ASW equipment which operates between 30 Hz and 10 kHz such as: Acoustic (Sonobouy) Receivers or Magnetic Anomaly Detectors (MAD)." Another subtle change is the specification that the loop winding resistance should be between 5  $\Omega$  and 10  $\Omega$ .

### **RE102 Radiated Emissions, Electric Field**

RE102 is applicable from 10 kHz to 18 GHz and is used to identify radiated emissions from the EUT and associated cables. It is intended to protect sensitive receivers from interference coupled through the antennas associated with the receiver. Many tuned receivers have sensitivities on the order of 1  $\mu$ V and are connected to intentional apertures (the antenna) that are constructed for efficient reception of energy in the operating range of the receiver. RE102 identifies specific antennas are specified for use in measurements. Antenna placement is defined including separation from the EUT and elevation from the floor. The number of antenna positions is de-

# Catch them because you can. With the new flagship in EMI testing.

The new R&S®ESW EMI test receiver catches them all, the spikes and other disturbances that may show up in your DUT. Thanks to its unrivalled dynamic range, its ultrafast FFT-based time domain scan and realtime spectrum analysis, there is no way to escape its analysis power. For certification or lab tasks – this is the instrument you can totally rely on.

Get the details: [www.rohde-schwarz.com/ad/esw](http://www.rohde-schwarz.com/ad/esw)



terminated based on size of the EUT and interfacing cables as well as beamwidth of the measurement antennas. Antenna placement is now based on EUT area and not just width. The RE102 limits vary with installation location, service branch and platform.

Changes to MIL-STD-41G for RE102 include setting the upper test frequency to 18 GHz for all applications versus 1 GHz or 10 times the highest intentionally generated frequency in previous versions. Another change is specifying the measurement system check frequencies as 10.5 kHz, 2.1 MHz, 12 MHz and 29.5 MHz for the active rod antenna instead of low mid and high frequencies, 197 MHz for the biconical antenna, 990 MHz for the large horn and 17.5 GHz for the small horn. However, the largest change in RE102 is a small change in wording regarding antenna positioning. Previous versions required that the number of antenna positions used above 200 MHz be based on the width of the EUT and the first 35 cm of interfacing cables from 200 MHz to 1 GHz and the first 7 cm of interfacing cables from 1 GHz to 18 GHz as related to the 3 dB beamwidth of the measurement antenna. MIL-STD-461G changes the word “width” to “area” thus bringing the height of an EUT into the equation and thus potentially adding more positions. This was a much-needed change in order to more accurately test large vertical test objects such as shipboard racks. There are also minor changes to the 41” rod antenna set-up.

### **RE103 Radiated Emissions, Antenna Spurious and Harmonic Outputs**

RE103 may be used as an alternative for CE106 when testing transmitters with their intended antennas. CE106 should be used whenever possible. However, for systems using active antenna or when the antenna is not removable or the transmit power is too high, RE103 should be invoked. RE103 is applicable essentially identical to CE106 for transmitters in the transmit mode in terms of frequency ranges and amplitude limits. The frequency range of test is based on the EUT operating frequency. The test procedure is laborious and will require a large open area to meet antenna separation distances in many cases. The minimum acceptable antenna separations are calculated based on antenna size and operating frequency of the EUT and measurements in azimuth and elevation are required.

### **RS101 Radiated Susceptibility, Magnetic Field**

RS101 is a specialized test applicable from 30 Hz to 100 kHz for Army and Navy ground equipment having a minesweeping or mine detection capability,

for Navy ships and submarines, that have an operating frequency of 100 kHz or less and an operating sensitivity of 1  $\mu$ V or better (such as 0.5  $\mu$ V), for Navy aircraft equipment installed on ASW capable aircraft, and external equipment on aircraft that are capable of being launched by electromagnetic launch systems. The requirement is not applicable for electromagnetic coupling via antennas. RS101 is intended to ensure that performance of equipment susceptible to low frequency magnetic fields is not degraded. Two different limits are cited based on service branch. The Navy RS101 limit was established by measurement of magnetic field radiation from power distribution components (transformers and cables), and the magnetic field environment of Navy platforms. The Army RS101 limit is based on 5 mV (independent of frequency) being induced in a 12.7 cm (5 inch) diameter loop.

An alternative test approach using Helmholtz coils is provided. Helmholtz coils generate a relatively uniform magnetic field that is more representative of the environment experienced on some platforms, particularly submarines. For this reason, the AC Helmholtz coil test option is preferred for submarine applications.

### **RS103 Radiated Susceptibility, Electric Field**

RS103 is applicable from 2 MHz to 18 GHz in general, but the upper frequency can be as high as 40 GHz if specified by the procuring agency. It is applicable to both the EUT enclosures and EUT associated cabling. The primary concern is to ensure that equipment will operate without degradation in the presence of electromagnetic fields generated by antenna transmissions both onboard and external to the platform. The limits are platform dependent and are based on levels expected to be encountered during the service life of the equipment. It should be noted that RS103 may not necessarily be the worst-case environment to which the equipment may be exposed. For aircraft and ships, different limits are specified depending on whether the equipment receives protection from platform structure. Alternative method and procedures are provided for use in a mode-tuned reverberation chamber from 200 MHz to 40 GHz.

Changes to MIL-STD-41G for RS103 include requiring testing below 30 MHz for Army and Navy applications, but optional for all others. Additionally, receivers with permanently attached antennas, are allowed reduced performance over the intended receiver band of operation, but must meet its perfor-



mance requirements after in-band exposure to the radiated field.

The major change for RS103 is identical to that of RE102 explained above – illumination of test set-up area, not just width.

### **RS105 Radiated Susceptibility, Transient Electromagnetic Field**

RS105 is intended to demonstrate the ability of the EUT to withstand the fast rise time, free-field transient environment of EMP. RS105 applies for equipment enclosures which are directly exposed to the incident field outside of the platform structure or for equipment inside poorly shielded or unshielded platforms and the electrical interface cabling should be protected in shielded conduit. The EMP field is simulated in the laboratory using bounded wave TEM radiators such as TEM cells and parallel plate transmission lines. Since the polarization of the incident EMP field in the installation is not known, the EUT must be tested in all orthogonal axes. Potential equipment responses due to cable coupling are controlled under CS116. Full RS105 testing capability is rare.

### **About the Author**

Tony Keys is the President and Principal Consultant for EMC Analytical Services. Mr. Keys has over 20 years of experience in Electromagnetic Environmental Effects (E3) engineering. His experience covers a wide range of E3 specialty areas from a multitude of organizational aspects including E3 support contracting, DoD E3 service, and DoD system development. He can be reached at [tony.keys@emcanalyticalservices.com](mailto:tony.keys@emcanalyticalservices.com).

The author would like to thank Ken Javor for his significant contribution to the article.

Mr. Javor has worked in the EMC industry for over 30 years. He is a consultant to government and industry, runs a pre-compliance EMI testing facility, and curates the Museum of EMC Antiquities, a collection of radios and instruments that were important in the development of the discipline, as well as a library of important documentation. He can be reached at [ken.javor@emccompliance.com](mailto:ken.javor@emccompliance.com).

# RENT EMC TEST GEAR

## LARGEST SELECTION OF TEST EQUIPMENT

Conducted Emissions & Immunity:

ESD Guns • EFT/Burst • CDN/LISN • Dips & Interrupts • Field Probes & Monitors

Radiated Emissions & Immunity:

Amplifiers • Antennas • Signal Generators • EMI Receivers • Power Meters • Surge

## FROM TRUSTED BRANDS

AE Techron • Amplifier Research • Com-Power  
EMC Partner • Empower • EM Test • ETS-Lindgren  
Haefely • IFI • Keysight • Keytek • Montena  
Narda • NoiseKen • Rohde & Schwarz • Solar  
Teseq and more...

## TO MEET A VARIETY OF STANDARDS

MIL-STD-461 • DO-160 • IEC 61000 • IEC 60601-1-2

ANSI C62 • ISO 7637 • MIL-STD-1275 • CISPR



**ADVANCED TEST EQUIPMENT RENTALS**

*The Knowledge. The Equipment. The Solution.*

Visit our site [www.atecorp.com](http://www.atecorp.com)



800-404-ATEC (2832) US & Canada • 001 800 0404 2832 Int'l • 858-558-6500 Direct



# Military Related E3 Documents and POCs

---

## TONY KEYS

EMC Analytical Services

The following references are not intended to be all inclusive, but rather a representation of available sources of additional information.





MIL-HDBK-235-1C Military Operational Electromagnetic Environment Profiles Part 1C General Guidance, 1 Oct 2010.

MIL-HDBK-237D Electromagnetic Environmental Effects and Spectrum Certification Guidance for the Acquisition Process, 20 May 2005.

MIL-HDBK-240A Hazards of Electromagnetic Radiation to Ordnance (HERO) Test Guide, 10Mar2011.

MIL-HDBK-263B Electrostatic Discharge Control Handbook for Protection of Electrical and Electronic Parts, Assemblies and Equipment (Excluding Electrically Initiated Explosive Devices), 31 Jul 1994.

MIL-HDBK-274A Electrical Grounding for Aircraft Safety, 14 Nov 2011.

MIL-HDBK-335 Management and Design Guidance Electromagnetic Radiation Hardness for Air Launched Ordnance Systems, Notice 4, 08 Jul 2008.

MIL-HDBK-419A Grounding, Bonding, and Shielding for Electronic Equipment and Facilities, 29 Dec 1987.

MIL-HDBK-454B General Guidelines for Electronic Equipment, 15 Apr 2007.

MIL-HDBK-1004-6 Lightning Protection, 30 May 1988.

MIL-HDBK-1195, Radio Frequency Shielded Enclosures, 30 Sep 1988.

MIL-HDBK-1512 Electroexplosive Subsystems, Electrically Initiated, Design Requirements and Test Methods, 30 Sep 1997.

MIL-HDBK-1857 Grounding, Bonding and Shielding Design Practices, 27 Mar 1998.

MIL-STD-188-124B Grounding, Bonding, and Shielding for Common Long Haul/Tactical Communications-Electronics Facilities and Equipment, 18 Dec 2000.

MIL-STD-188-125-1 High-Altitude Electromagnetic Pulse (HEMP) Protection for Ground-Based C41 Facilities Performing Critical, Time-Urgent Missions Part 1 Fixed Facilities, 17 Jul 1998.

MIL-STD-220C Test Method Standard Method of Insertion Loss Measurement, 14 May 2009.

MIL-STD-331CFuze and Fuze Components, Environmental and Performance Tests for, 22 Jun 2009.

MIL-STD-449D Radio Frequency Spectrum Characteristics, Measurement of, 22 Feb 1973.

MIL-STD-461F Requirements for the Control of Electromagnetic Interference Characteristics of Subsystems and Equipment, 10 Dec 2007.

MIL-STD-461G Requirements for the Control of Electromagnetic Interference Characteristics of Subsystems and Equipment, 11 Dec 2015.

MIL-STD-464C Electromagnetic Environmental Effects Requirements for Systems, 01 Dec 2010.

MIL-STD-704E Aircraft Electric Power Characteristics, 12 Mar 2004.

MIL-STD-1310H Standard Practice for Shipboard Bonding, Grounding, and Other Techniques for Electromagnetic Compatibility Electromagnetic Pulse (EMP) Mitigation and Safety, 17 Sep 2009.

MIL-STD-1377 Effectiveness of Cable, Connector, and Weapon Enclosure Shielding and Filters in Precluding Hazards of EM Radiation to Ordnance; Measurement of, 20 Aug 1971.

MIL-STD-1399 Section 300B Interface Standard for Shipboard Systems, Electric Power, Alternating Current, 24 Apr 2008.

MIL-STD-1541A Electromagnetic Compatibility Requirements for Space Systems, 30 Dec 1987.

MIL-STD-1542B Electromagnetic Compatibility and Grounding Requirements for Space System Facilities, 15 Nov 1991.

MIL-STD-1605 Procedures for Conducting a Shipboard Electromagnetic Interference (EMI) Survey (Surface Ships), 08 Oct 2009.

MIL-STD-1686C Electrostatic Discharge Control Program for Protection of Electrical and Electronic Parts, Assemblies, and Equipment (Excluding Electrically Initiated Explosive Devices). 25 Oct 1995.

ADS-37A-PRF Electromagnetic Environmental Effects (E3) Performance and Verification Requirements, 28 May 1996.

DOD-STD-1399 Section 070 Part 1 D.C. Magnetic Field Environment, Notice 1, 30 Nov 1989.

DoDI 3222.03 DoD Electromagnetic Environmental Effects (E3) Program, 24Aug 2014.

DoDD 4650.01 Policy and Procedures for Management and Use of the Electromagnetic Spectrum, 09 Jan 2009.

DoDI 6055.11 Protecting Personnel from Electromagnetic Fields, 19 Aug 2009.

AIAA - S-121-2009e - Electromagnetic Compatibility Requirements for Space Equipment and Systems

ITU Recommendation SM.1541-6 (08/2015) - Unwanted emissions in the out-of-band domain

ITU Recommendation M.1314-1 (06/05) - Reduction of unwanted emissions of radar systems operating above 400 MHz

ITU Recommendation M.1177 (04/2011) - Techniques for measurement of unwanted emissions of radar systems

ITU ITU-R SG01 Contribution 75 (06/2013) - Draft new Recommendation ITU-R SM.[SPEC\_MON\_EVOLUTION] - Spectrum monitoring evolution

NASA GSFC-STD-7000A, GODDARD TECHNICAL STANDARD: GENERAL ENVIRONMENTAL VERIFICATION STANDARD (GEVS) FOR GSFC FLIGHT PROGRAMS AND PROJECTS (22-APR-2013)

RTCA DO-160G 12/2010 for Airborne equipment

NAVAIR  
Naval Air Systems Command  
Code: 4.1.13  
48187 Standley Road  
Building 4010  
Patuxent River, MD 20670  
Mr. Craig Simmons  
DSN 342-4907; Commercial (301) 342-4907  
E-mail: craig.simmons@navy.mil

AIR FORCE  
AFLCMC/EZAC, Building 28  
2145 Monahan Way  
Wright Patterson AFB, OH 45433-7017  
Mr. Joseph DeBoy  
DSN 785-6995; Commercial (937) 255-6995  
E-mail: joseph.deboy@us.af.mil

### **About the Author**

Tony Keys is the President and Principal Consultant for EMC Analytical Services. Mr. Keys has over 20 years of experience in Electromagnetic Environmental Effects (E3) engineering. His experience covers a wide range of E3 specialty areas from a multitude of organizational aspects including E3 support contracting, DoD E3 service, and DoD system development. He can be reached at [tony.keys@emcanalyticalservices.com](mailto:tony.keys@emcanalyticalservices.com).

### **DOD E3 Point of Contacts**

ARMY  
Commander, U.S. Army, AMRDEC  
RDMR-AES-E3  
Building 4488  
Redstone Arsenal, AL 35898  
Mr. Duane Driver  
DSN 897-8447; Commercial (256) 313-8447  
E-mail: [duane.e.driver.civ@mail.mil](mailto:duane.e.driver.civ@mail.mil)



# Exhibition Space is Filling Up Fast. Book Your Booth Today!



**September 20-22**  
**Hynes Convention Center**  
**Boston, MA**

Join the Growing List of Exhibitors:

Keysight Technologies	Microlab	Noisewave
Rohde & Schwarz	Wireless Telecom Group	Nuhertz Technologies, LLC
National Instruments/AWR	COMSOL, Inc.	Ophir RF
CST - Computer Simulation Technology AG	Dynaware Incorporated	Orban Microwave
Mini-Circuits	EMSCAN	Piconics
Analog Devices	EZ Form Cable Corp.	Planar Monolithics
ANSYS	GigaTest Labs	PPG Aerospace-Curing Microwave
Copper Mountain Technologies	Gowanda Electronics	Queen Screw & MFG, Inc.
Electro Rent Corporation	High Frequency Electronics	Reactel, Inc.
Freescale/ NXP Semiconductors	Holzworth Instrumentation	Response Microwave, Inc.
Rogers Corp.	Instec	Semiconductor Enclosures
A.J. Tuck Company	Integrated Device Technology (IDT)	SemiGen, Inc.
Accurate Circuit Engineering	International Manufacturing Services	Southwest Microwave
AEM	Ion Beam Milling	SV Microwave
Agile Microwave Technology Inc.	IW Microwave Products Division	Synergy Microwave Corporation
Altair Engineering	JFW Industries, Inc.	Taconic
Amplipal Corp.	Lake Shore Crytronics	TechPlus Microwave, Inc.
Anokiwave	LPKF Laser and Electronics	Tech-X Corporation
Applied Thin-Film Products	MACOM	Times Microwave Systems
AR RF/Microwave Instrumentation	Marki Microwave	TowerJazz
ARC Technologies	Massachusetts Bay Technologies	Transline Technology Inc.
ATE Systems	Maury Microwave	T-Tech, Inc.
Barry Industries	Mentor Graphics Corp.	TTE Filters, LLC
Berkeley Nucleonics	Microwave Product Digest	Weinschel Associates
Boonton	Millitech	Werlatone, Inc.
Colby Instruments	Mitsubishi Electric US	X-Microwave
Noisecom	Modular Components National	Zentech Manufacturing

**Contact your MWJ Sales Representative or  
See us at IMS Booth #1410**

**EDICONUSA.com**

Premium Sponsors

Organized By





# Index of Advertisers

---



**Narda Safety Test Solutions**  
435 Moreland Road  
Hauppauge, NY, USA

t: (631) 231-1700  
e: [nardasts@l-3com.com](mailto:nardasts@l-3com.com)  
w: [www.narda-sts.us](http://www.narda-sts.us)



A Thermo Fisher Scientific Brand

**Thermo Fisher Scientific**  
81 Wyman Street  
Waltham, MA USA 02451

t: (800) 556-2323  
w: [www.thermoscientific.com](http://www.thermoscientific.com)



**Pearson Electronics**  
4009 Transport Street,  
Palo Alto, CA 94303

t: (650) 494-6444  
e: [sales@pearsonelectronics.com](mailto:sales@pearsonelectronics.com)  
w: [www.pearsonelectronics.com](http://www.pearsonelectronics.com)



**IFI Instruments For Industry**  
903 South Second Street  
Ronkonkoma, NY

t: (631) 467-8400  
e: [sales@ifi.com](mailto:sales@ifi.com)  
w: [www.ifi.com](http://www.ifi.com)



**MegaPhase**  
122 Banner Road,  
Stroudsburg, PA 18360-6433

t: (570) 424-8400  
e: [solutions@megaphase.com](mailto:solutions@megaphase.com)  
w: [www.megaphase.com](http://www.megaphase.com)



**Coilcraft Inc.**  
1102 Silver Lake Road  
Cary, IL 60013

t: (800) 322-2645  
e: [sales@coilcraft.com](mailto:sales@coilcraft.com)  
w: [www.coilcraft.com](http://www.coilcraft.com)



**GAUSS INSTRUMENTS GmbH**  
Agnes-Pockels-Bogen 1  
80992 Munich, Germany

t: +49.89.54 04 699.0  
e: [info@tdemi.com](mailto:info@tdemi.com)  
w: [www.gauss-instruments.com](http://www.gauss-instruments.com)



**Empower RF Systems, Inc.**  
316 West Florence Ave.  
Inglewood, CA 90301

t: (310) 412-8100  
e: [sales@empowerrf.com](mailto:sales@empowerrf.com)  
w: [www.empowerrf.com](http://www.empowerrf.com)



**Rohde & Schwarz USA, Inc.**  
6821 Benjamin Franklin Drive  
Columbia, MD 21046

t: (410) 910-7800  
e: [Info@rsa.rohde-schwarz.com](mailto:Info@rsa.rohde-schwarz.com)  
w: [www.rohde-schwarz.com](http://www.rohde-schwarz.com)



**Advanced Test Equipment Corp**  
10401 Roselle Street  
San Diego, CA 92121

t: (858) 558-6500  
e: [sales@atecorp.com](mailto:sales@atecorp.com)  
w: [www.atecorp.com](http://www.atecorp.com)

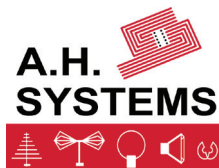

**A.H. Systems, inc.**  
9710 Cozycroft Ave.  
Chatsworth, CA 91311

t: (818) 998-0223  
e: [sales@ahsystems.com](mailto:sales@ahsystems.com)  
w: [www.ahsystems.com](http://www.ahsystems.com)



**Microwave Journal**  
685 Canton St.  
Norwood, MA 02062 USA

t: (847) 763-4943  
e: [mwj@halldata.com](mailto:mwj@halldata.com)  
w: [www.microwavejournal.com](http://www.microwavejournal.com)